



Compact cylinder—ACF Series

In accordance with ISO21287 standard

Compendium of ACF Series

In accordance with ISO21287 standard
In accordance with ISO21287 standard, the mounting size is vogue.

Two kinds of rod type

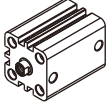

Female thread

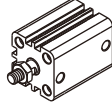

Male thread

Magnetic switch slots around the cylinder body
There are magnetic switch slots around the cylinder body convenient to install inducting switch.

Multi-mounting accessories

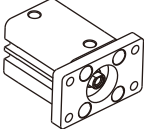

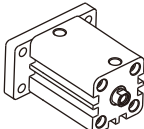
FA Type

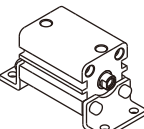

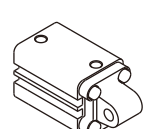
FB Type

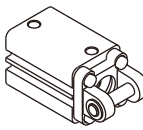

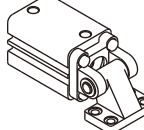
LB Type

CA Type

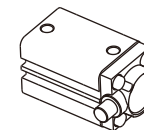



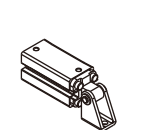

CB Type

CR Type

FTC Type

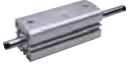
SDB Type

Multi-type cylinder

ACF: Compact cylinder (Double acting)	
ASF: Compact cylinder (Single acting-push)	
ATF: Compact cylinder (Single acting-pull)	
ACFD: Compact cylinder (Double rod)	
ACFJ: Compact cylinder (Adjustable stroke)	
TACF: Compact cylinder (Double acting non-rotating with yoke)	
TACFD: Compact cylinder (Double rod non-rotating with yoke)	

Compact structure
Compact structure can effectively save fifty percent installation space with ISO15552 standard cylinder.

Eleven bore size are available
Bore size: 12, 16, 20, 25, 32, 40, 50, 63

Criteria for selection: Cylinder thrust

Unit : Newton(N)

Bore size	Rod size	Acting type	Pressure area(mm ²)	Operating pressure(MPa)								Bore size	Rod size	Acting type	Pressure area(mm ²)	Operating pressure(MPa)							
				0.1	0.2	0.3	0.4	0.5	0.6	0.7	0.1					0.2	0.3	0.4	0.5	0.6	0.7		
12	6	Single acting	Push side	113.1	-	6.1	17.4	28.7	40.0	51.4	62.7	32	12	Single acting	Push side	804.2	30.8	111.2	191.7	272.1	352.5	432.9	513.4
			Pull side	84.8	-	0.5	8.9	17.4	25.9	34.4	42.9				Pull side	691.2	19.5	88.6	157.7	226.9	296.0	365.1	434.2
		Double acting	Push side	113.1	11.3	22.6	33.9	45.2	56.5	67.9	79.2			Double acting	Push side	804.2	80.4	160.8	241.3	321.7	402.1	482.5	563.0
			Pull side	84.8	8.5	17.0	25.4	33.9	42.4	50.9	59.4				Pull side	691.2	69.1	138.2	207.3	276.5	345.6	414.7	483.8
16	8	Single acting	Push side	201.1	-	18.1	38.2	58.3	78.4	98.5	118.6	40	12	Single acting	Push side	1256.6	54.2	179.8	305.5	431.2	556.8	682.5	808.1
			Pull side	150.8	-	8.1	23.1	38.2	53.3	68.4	83.5				Pull side	1143.5	42.9	157.2	271.6	385.9	500.3	614.6	729.0
		Double acting	Push side	201.1	20.1	40.2	60.3	80.4	100.5	120.6	140.7			Double acting	Push side	1256.6	125.7	251.3	377.0	502.7	628.3	754.0	879.6
			Pull side	150.8	15.1	30.2	45.2	60.3	75.4	90.5	105.6				Pull side	1143.5	114.4	228.7	343.1	457.4	571.8	686.1	800.5
20	10	Single acting	Push side	314.2	-	33.1	64.5	96.0	127.4	158.8	190.2	50	16	Single acting	Push side	1963.5	90.1	286.5	482.8	679.2	875.5	1071.9	1268.2
			Pull side	235.6	-	17.4	41.0	64.5	88.1	111.7	135.2				Pull side	1762.4	70.0	246.3	422.5	598.8	775.0	951.3	1127.5
		Double acting	Push side	314.2	31.4	62.8	94.2	125.7	157.1	188.5	219.9			Double acting	Push side	1963.5	196.3	392.7	589.0	785.4	981.7	1178.1	1374.4
			Pull side	235.6	23.6	47.1	70.7	94.2	117.8	141.4	164.9				Pull side	1762.4	176.2	352.5	528.7	705.0	881.2	1057.5	1233.7
25	10	Single acting	Push side	490.9	13.8	62.9	112.0	161.0	210.1	259.2	308.3	63	16	Single acting	Push side	3117.2	173.6	485.3	797.1	1108.8	1420.5	1732.2	2044.0
			Pull side	412.3	5.9	47.2	88.4	129.6	170.9	212.1	253.3				Pull side	2916.2	153.5	445.1	736.8	1028.4	1320.0	1611.6	1903.2
		Double acting	Push side	490.9	49.1	98.2	147.3	196.3	245.4	294.5	343.6			Double acting	Push side	3117.2	311.7	623.4	935.2	1246.9	1558.6	1870.3	2182.1
			Pull side	412.3	41.2	82.5	123.7	164.9	206.2	247.4	288.6				Pull side	2916.2	291.6	583.2	874.9	1166.5	1458.1	1749.7	2041.3

Installation and application



1. When load changes in the work, the cylinder with abundant output capacity shall be selected.
2. Relative cylinder with high temperature resistance or corrosion resistance shall be chosen under the condition of high temperature or corrosion.
3. Necessary protection measure shall be taken in the environment with higher humidity, much dust or water drops, oil dust and welding drips.
4. Dirty substances in the pipe must be eliminated before cylinder is connected with pipeline to prevent the entrance of particles into the cylinder.
5. The medium used by cylinder shall be filtered to 40µm or below.
6. As both of the front cover and piston of the cylinder are short, typically too large stroke can not be selected.
7. Anti-freezing measure shall be adopted under low temperature environment to prevent moisture freezing.
8. The cylinder shall avoid the influence of side load in operation to maintain the normal work of cylinder and extend the service life.
9. If the cylinder is dismantled and stored for a long time, please conduct anti-rust treatment to the surface. Anti-dust caps shall be added in air inlet and outlet ports. The front and back cover can not be dismantled, which shall be especially noticed.



ISO21287 Compact cylinder

ACF Series



Symbol

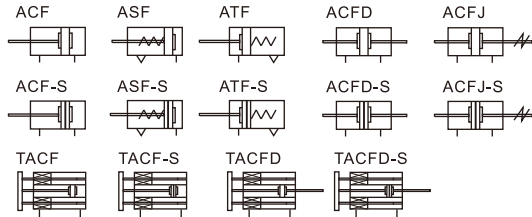

Product feature

- In accordance with ISO21287 standard, the mounting size is vogue.
- C clip is adopted to connect the cylinder body and back cover or front cover, and riveted structure is adopted to connect piston and piston rod to make it compact and reliable.
- The internal diameter of the body is treated with rolling followed by the treatment of hard anodizing, forming an excellent abrasion resistance and durability.
- The seal of piston adopts heterogeneous two-way seal structure. It has compact dimension and the function of oil reservation.
- Compact structure can effectively save fifty percent installation space with ISO15552 standard cylinder.
- There are magnetic switch slots around the cylinder body, which is convenient to install inducting switch.
- Bumper is available and it can available absorb excrement energy.
- Installing accessories with various specifications are optional.

Specification

Bore size(mm)	12	16	20	25	32	40	50	63
Acting type	Double acting							
	Single acting_Push type、Single acting_Pull type							
Fluid	Air(to be filtered by 40μm filter element)							
Operating pressure	Double acting	0.15~1.0MPa(22~145psi)						
	Single acting	0.2~1.0MPa(28~145psi)						
Proof pressure	1.5MPa(215psi)							
Temperature °C	-20~70							
Speed range mm/s	Double acting : 30~500 Single acting : 50~500							
Stroke tolerance	Stroke≤100 ^{+1.0} ₀ Stroke>100 ^{+1.5} ₀							
Cushion type	Bumper							
Port size [Note1]	M5×0.8				1/8"			

[Note1] G thread is available.

Stroke

Bore size (mm)	Standard stroke (mm)															Max.stroke												
	12	16	20	25	30	35	40	45	50	55	60	70	75	80	90		100											
Common type	Double acting	12	5	10	15	20	25	30	35	40	45	50					50											
		16	5	10	15	20	25	30	35	40	45	50	55	60	70	75	75											
		20	5	10	15	20	25	30	35	40	45	50	55	60	70	75	80	90	100									
		25	5	10	15	20	25	30	35	40	45	50	55	60	70	75	80	90	100	110	120	125	150					
		32 40	5	10	15	20	25	30	35	40	45	50	55	60	70	75	80	90	100	110	120	125	150	160	175	200		
Non-rotating with yoke	Double acting	50 63	5	10	15	20	25	30	35	40	45	50	55	60	70	75	80	90	100	110	120	125	150	160	175	200	225	250
		12	5	10																								10
		16~63	5	10	15	20	25																					25
		12	5	10	15	20	25	30	35	40	45	50																50
		16	5	10	15	20	25	30	35	40	45	50	55	60	70	75												75
Non-rotating with yoke	Single acting	20 25	5	10	15	20	25	30	35	40	45	50	55	60	70	75	80	90	100								100	
		32 40	5	10	15	20	25	30	35	40	45	50	55	60	70	75	80	90	100								100	
		50 63	5	10	15	20	25	30	35	40	45	50	55	60	70	75	80	90	100								100	

- Note) 1. Please contact the company for other special strokes.
 2. The dimensions of non-std stroke cylinder has the same dimensions as the next longer stroke std. stroke cylinder. e.g. 23mm stroke cylinder has the same dimensions of 25 std. stroke cylinder.

Ordering code

ACF 20 ×30 S B □ G
 ACFD 20 ×30 S B □ G
 ACFJ 20 ×30 -30 S B □ G

① ② ③ ④ ⑤ ⑥ ⑦ ⑧

① Model	② Bore size	③ Stroke	④ Adjustable Stroke	⑤ Magnet	⑥ Rod type	⑦ Mounting type [Note1]	⑧ Thread type[Note2]
ACF: Compact cylinder (Double acting)	12 16 20 25 32 40 50 63	Refer to stroke table for details	No this code	Blank: Without magnet S: With magnet	Blank: Female thread B: Male thread	Blank: No accessories FA: FA type FB: FB type CA: CA type CB: CB type	G: G Thread
ASF: Compact cylinder (Single acting-push)							
ATF: Compact cylinder (Single acting-pull)							
TACF: Compact cylinder (Double acting non-rotating with yoke)					Blank: No accessories FB: FB type CA: CA type	CB: CB type CR: CR type FTC: FTC type	
TACFD: Compact cylinder (Double rod non-rotating with yoke)							
ACFD: Compact cylinder (Double rod)							
ACFJ: Compact cylinder (Adjustable stroke)					10 20 30 40 50 75 100	Blank: Female thread B: Male thread	

[Note1] Please refer to page 314~316 for accessory parts; CR must be used with CB, SDB must be used with CA, FTC must be used with TCM2.

[Note2] Standard thread is blank here.

ISO21287 Compact cylinder

ACF Series

Inner structure and material of major parts

ACF-S

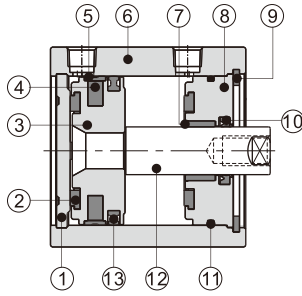

TACF-S

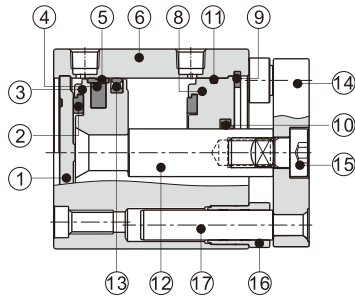

NO.	Item	Material
1	Back cover	No(Φ12、16)\(Aluminum alloy(Others))
2	Bumper	TPU
3	Piston	Brass(Φ12、16)\(Aluminum alloy(Others))
4	Magnet	Sintered metal(Neodymium-iron-boron)(Φ12~16)\Plastic(Others)
5	Wear ring	No(Φ12~32)\Wear resistant material(Others)
6	Body	Aluminum alloy
7	Bushing	No(Φ12~32)\Wear resistant material(Others)
8	Front cover	Aluminum alloy
9	C clip	Spring steel
10	Front cover packing	NBR
11	O-ring	NBR
12	Piston rod	S45C
13	Piston seal	NBR
14	Panel	Aluminum alloy
15	Screw	Carbon steel
16	Bushing	Brass
17	Guide rod	Stainless steel(Φ12~40)\S45C(Others)

Dimensions

ACF

Φ12

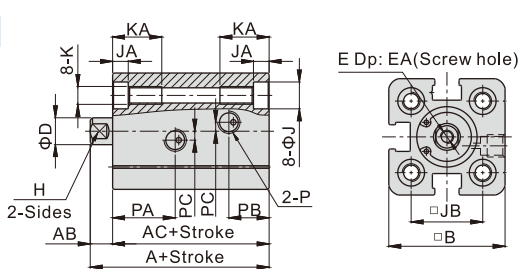

Φ16~Φ25

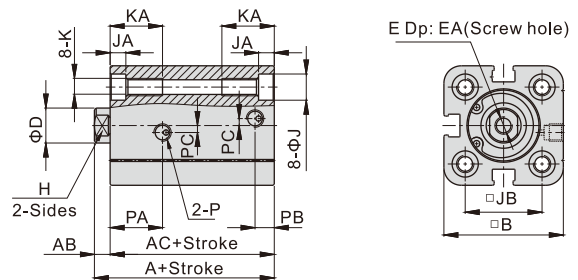

Φ32~Φ63

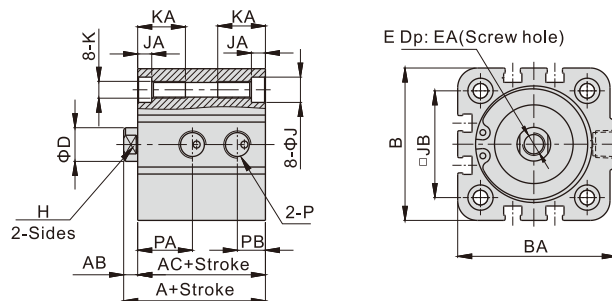

Bore size\Item	A	AB	AC	B	BA	D	E	EA	H	J	JA	JB	K	KA	P	PA	PB	PC
12	40	5	35	26	-	6	M3×0.5	6	5	6	3.5	16	M4×0.7	11	M5×0.8	14	9	2
16	40	5	35	29	-	8	M4×0.7	8	6	6	3.5	18	M4×0.7	11	M5×0.8	14.5	5.5	2
20	43	6	37	34	-	10	M6×1.0	12	8	7.5	4.5	22	M5×0.8	15	M5×0.8	15	5.5	2
25	45	6	39	39.5	-	10	M6×1.0	12	8	7.5	4.5	26	M5×0.8	15	M5×0.8	16.5	5.5	2
32	51	7	44	48.5	50	12	M8×1.25	13	10	9	5	32.5	M6×1.0	17	G1/8	18	8.5	-
40	52.5	7	45.5	54	56.5	12	M8×1.25	13	10	9	5	38	M6×1.0	17	G1/8	19.5	10	-
50	53.5	8	45.5	64.5	67	16	M10×1.5	16	14	10.5	5	46.5	M8×1.25	20	G1/8	19.5	10.5	-
63	57	8	49	74.5	78.5	16	M10×1.5	16	14	10.5	5	56.5	M8×1.25	20	G1/8	19.5	12	-

Remark: The dimensions of magnet type cylinder are the same as non-magnet type cylinder. Please refer to page 313 for male thread dimensions.

ISO21287 Compact cylinder

ACF Series

ASF

Φ12

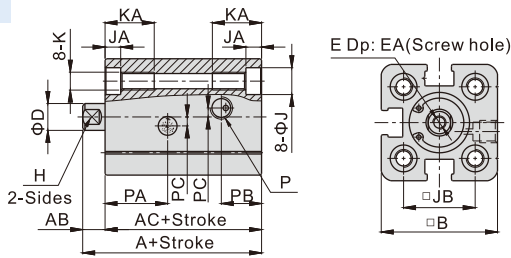

Φ16~Φ25

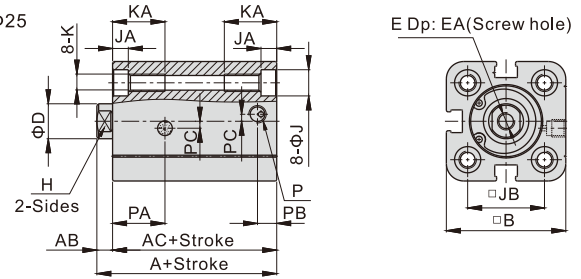

Φ32~Φ63

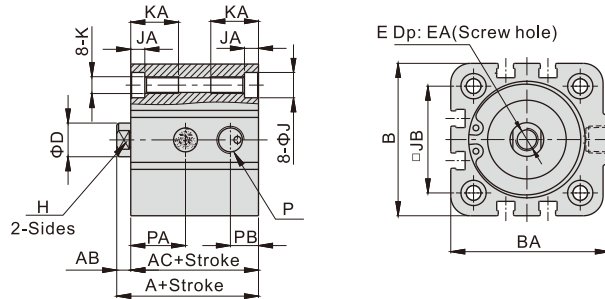

ATF

Φ12

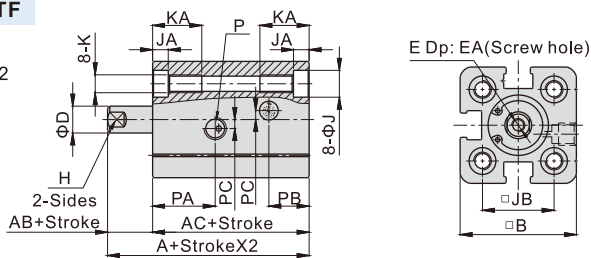

Φ16~Φ25

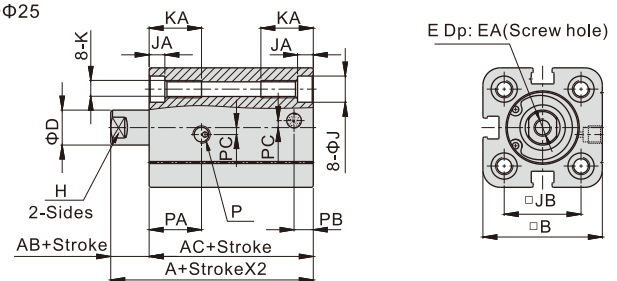

Φ32~Φ63

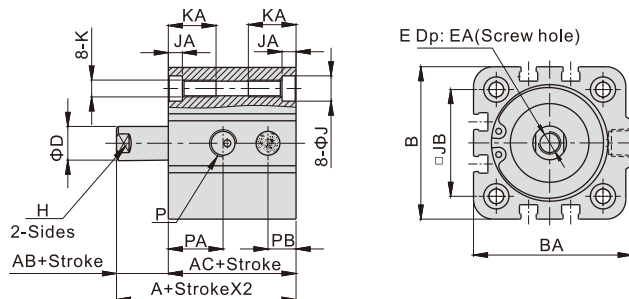

Bore size/Item	A	AB	AC	B	BA	D	E	EA	H	J	JA	JB	K	KA	P	PA	PB	PC
12	40	5	35	26	-	6	M3×0.5	6	5	6	3.5	16	M4×0.7	11	M5×0.8	14	9	2
16	40	5	35	29	-	8	M4×0.7	8	6	6	3.5	18	M4×0.7	11	M5×0.8	14.5	5.5	2
20	43	6	37	34	-	10	M6×1.0	12	8	7.5	4.5	22	M5×0.8	15	M5×0.8	15	5.5	2
25	45	6	39	39.5	-	10	M6×1.0	12	8	7.5	4.5	26	M5×0.8	15	M5×0.8	16.5	5.5	2
32	51	7	44	48.5	50	12	M8×1.25	13	10	9	5	32.5	M6×1.0	17	G1/8	18	8.5	-
40	52.5	7	45.5	54	56.5	12	M8×1.25	13	10	9	5	38	M6×1.0	17	G1/8	19.5	10	-
50	53.5	8	45.5	64.5	67	12	M10×1.5	16	14	10.5	5	46.5	M8×1.25	20	G1/8	19.5	10.5	-
63	57	8	49	74.5	78.5	16	M10×1.5	16	14	10.5	5	56.5	M8×1.25	20	G1/8	19.5	12	-

Remark: The dimensions of magnet type cylinder are the same as non-magnet type cylinder. Please refer to page 313 for male thread dimensions.

ISO21287 Compact cylinder

ACF Series

ACFD

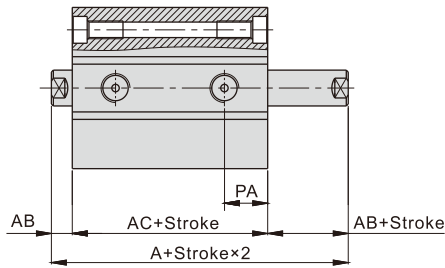

ACFJ

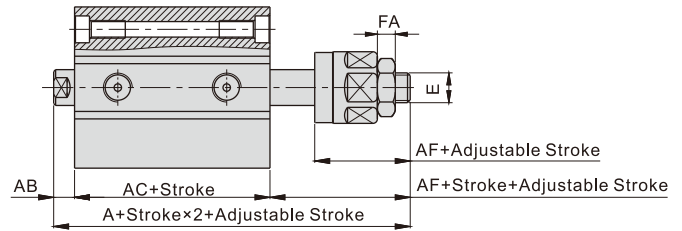

Bore size\Item	A(ACFD)	A(ACFJ)	AB	AC	AF	FA	PA	E
12	45	57	5	35	17	4	10.5	M5×0.8
16	45	61	5	35	21	5	10.5	M6×1.0
20	49	68	6	37	25	6	10.5	M8×1.25
25	51	70	6	39	25	6	11	M8×1.25
32	58	78	7	44	27	6	12.5	M10×1.25
40	59.5	79.5	7	45.5	27	6	13.5	M10×1.25
50	61.5	81.5	8	45.5	28	7	14.5	M12×1.25
63	65	85	8	49	28	7	15.5	M12×1.25

Remark:

1. The unmarked dimension is the same as ACF standard type
2. The dimensions of magnet type cylinder are the same as non-magnet type cylinder.

TACF

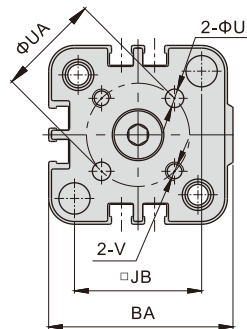
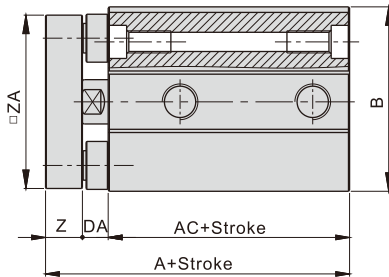

Male thread

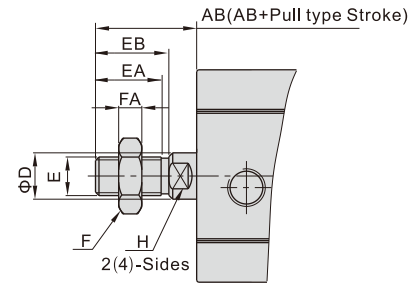

Bore size\Item	AB	D	E	EA	EB	F	FA	H
12	15	6	M5×0.8	9	10	8	4	5
16	17	8	M6×1.0	11	12	10	5	6
20	22	10	M8×1.25	14.5	16	12	6	8
25	22	10	M8×1.25	14.5	16	12	6	8
32	26	12	M10×1.25	17	19	17	6	10
40	26	12	M10×1.25	17	19	17	6	10
50	30	16	M12×1.25	20	22	17	7	14
63	30	16	M12×1.25	20	22	17	7	14

TACFD

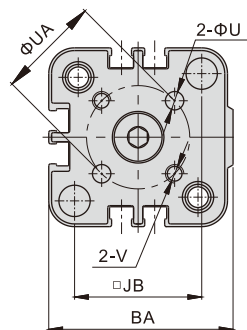
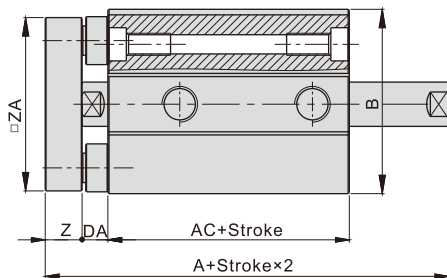

Bore size\Item	A(TACF)	A(TACFD)	AC	B	BA	DA	JB	U	UA	V	Z	ZA
12	46	51	35	26	-	5	16	3	12	M3×0.5	6	25
16	46	51	35	29	-	5	18	3	14	M3×0.5	6	28
20	51	57	37	34	-	6	22	4	17	M4×0.7	8	33
25	53	59	39	39.5	-	6	26	5	22	M5×0.8	8	38.5
32	61	68	44	48.5	50	7	32.5	5	28	M5×0.8	10	47
40	62.5	69.5	45.5	54	56.5	7	38	5	33	M5×0.8	10	52.5
50	65.5	73.5	45.5	64.5	67	8	46.5	6	42	M6×1.0	12	63
63	69	77	49	74.5	78.5	8	56.5	6	50	M6×1.0	12	73

Remark:

1. The unmarked dimension is the same as ACF standard type
2. The dimensions of magnet type cylinder are the same as non-magnet type cylinder.

ISO21287 Compact cylinder

ACF Series—Accessories

List for ordering code of accessories

Accessories Bore size	Mounting accessories								Knuckle				Sensor switch	
	LB	FA/FB	CA	CB	CR	SDB	FTC	TCM2	I	Y	F	U	CMSE	DMSE
12	F-ACE12LB	F-ACE12FA	F-ACE12CA	-	-	F-MI12SDB	-	-	F-ACQ12I	F-ACQ12Y	F-M5X080F	F-M5X080U	CMSE	DMSE
16	F-ACP12LB	F-ACE16FA	F-ACE16CA	-	-	F-MI12SDB	-	-	F-M6X100I	F-M6X100Y	F-M6X100F	F-M6X100U		
20	F-ACP20LB	F-ACE20FA	F-ACE20CA	-	-	F-MI20SDB	-	-	F-M8X125I	F-M8X125Y	F-M8X125F	F-M8X125U		
25	F-ACP25LB	F-ACE25FA	F-ACE25CA	-	-	F-MI20SDB	-	-						
32	F-ACE32LB	F-SI32FA	F-SE32CA	F-SE32CB	F-SI32CR	-	F-SI32FTC	F-SI32TCM2	F-M10X125I	F-M10X125Y	F-M10X125F	F-M10X125U		
40	F-ACE40LB	F-SI40FA	F-SE40CA	F-SE40CB	F-SI40CR	-	F-SI40FTC	F-SI40TCM2						
50	F-ACE50LB	F-SI50FA	F-SE50CA	F-SE50CB	F-SI50CR	-	F-SI50FTC	F-SI40TCM2	F-M12X125I	F-M12X125Y	F-M12X125F	F-M12X125U		
63	F-ACE63LB	F-SI63FA	F-SE63CA	F-SE63CB	F-SI63CR	-	F-SI63FTC	F-SI63TCM2						

Accessory selection

Cylinder model\Accessories			Mounting accessories									Knuckle[Note1]				Sensor switch	
			LB	FA	FB	CA	CB	CR	SDB	FTC	TCM2	I	Y	U	F	CMSE	DMSE
ACF	Female thread	Without magnet										x	x	x	x	x	x
		With magnet	•	•	•	•	•	•	•	•	•	•	•	•	•	•	•
	Male thread	Without magnet											x	x	x	x	x
		With magnet	•	•	•	•	•	•	•	•	•	•	•	•	•	•	•
ASF ATF	Female thread	Without magnet										x	x	x	x	x	x
		With magnet	•	•	•	•	•	•	•	•	•	•	•	•	•	•	•
	Male thread	Without magnet											x	x	x	x	x
		With magnet	•	•	•	•	•	•	•	•	•	•	•	•	•	•	•
ACFD ACFJ	Female thread	Without magnet										x	x	x	x	x	x
		With magnet	•	•	x	x	x	x	x	•	•	•	•	•	•	•	•
	Male thread	Without magnet											x	x	x	x	x
		With magnet	•	•	•	•	•	•	•	•	•	•	•	•	•	•	•
TACF	Female thread	Without magnet	x	x	•	•	•	•	•	•	•	x	x	x	x	x	x
		With magnet													•	•	
TACFD	Female thread	Without magnet	x	x	•	x	x	x	x	x	x	x	x	x	x	x	x
		With magnet													•	•	

[Note1] The I knuckle and Y knuckle for bore Φ12 are adaptable to ACQ cylinders, and other knuckles are common parts. Please refer to P520~523 for knuckle detail.

Material of accessories

Accessories Bore size	Mounting accessories									Knuckle			
	LB	FA	FB	CA	CB	CR	SDB	FTC	TCM2	I	Y	F	U
12~25	△	•	•	•	-	-	△	■	•	□	□	□	□
32~63	△	•	•	◇	◇	◇	-	■	•	□	□	□	□

•—Aluminum alloy ; ■—Cast iron ; ◇—Ductile Iron ; △—SPCC ; □—Carbon Steel

Dimensions

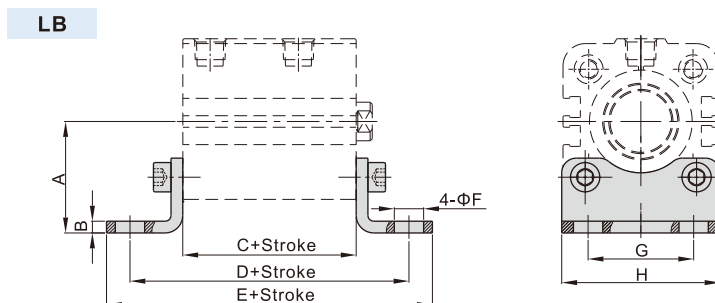

Bore size\Item	A	B	C	D	E	F	G	H
12	21	3	35	61	71	5.5	16	25
16	22	3	35	61	70.6	5.5	18	27
20	27	3.8	37	69	81.6	6.5	22	34
25	29	3.8	39	71	83.6	6.5	26	38
32	33.5	4	44	76	89	7	32	48
40	38	4	45.5	81.5	97.5	10	36	54
50	45	5	45.5	87.5	103.5	10	45	65
63	50	5	49	91	107	10	50	75

[Note] Valve C in the above table is only for ACF series. Please refer to relevant content for valve C of other series.

ISO21287 Compact cylinder

ACF Series—Accessories

FA/FB

Φ12~Φ25

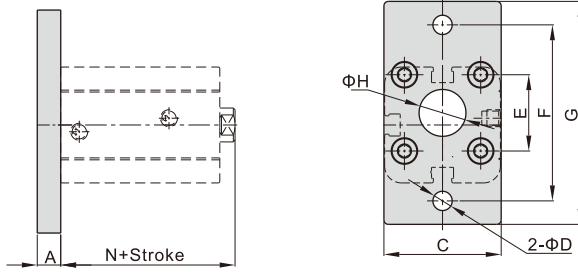

Φ32~Φ63

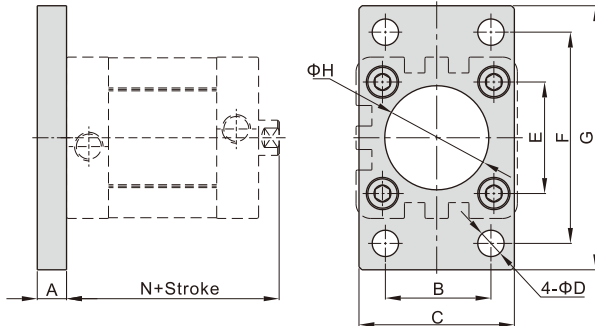

Bore size\Item	A	B	C	D	E	F	G	H	N
12	8	-	25	5.5	16	40	55	10	40
16	8	-	30	5.5	18	43	55	10	40
20	8	-	35	6.6	22	55	68	16	43
25	8	-	39.5	6.6	26	60	76	16	45
32	10	32	47	7	32.5	64	80	30.5	51
40	10	36	53	9	38	72	90	35.5	52.5
50	12	45	65	9	46.5	90	108	40.5	53.5
63	12	50	75	9	56.5	100	118	45.5	57

CA

Φ12~Φ25

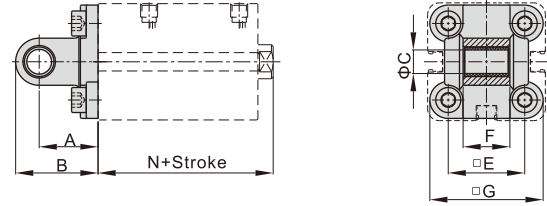

Φ32~Φ63

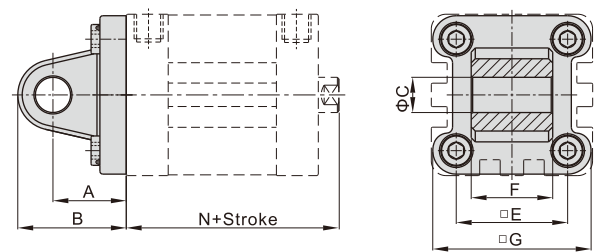

Bore size\Item	A	B	C	E	F	G	N
12	16	22	6	16	11.9	24	40
16	16	22	6	18	11.9	28.5	40
20	20	28	8	22	15.9	34.5	43
25	20	28	8	26	15.9	38.5	45
32	22	32.5	10	32.5	25.8	46.5	51
40	25	37	12	38	27.8	54	52.5
50	27	39	12	46.5	31.7	64	53.5
63	32	47	16	56.5	39.7	75	57

CB Φ32~Φ63

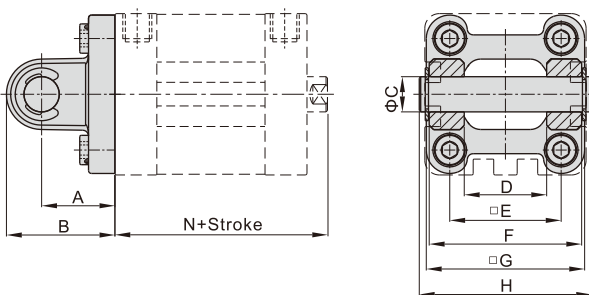

Bore size\Item	A	B	C	D	E	F	G	H	N
32	22	32.5	10	26	32.5	45	46.5	51	51
40	25	37	12	28	38	52	54	59	52.5
50	27	39	12	32	46.5	60	64	67	53.5
63	32	47	16	40	56.5	70	75	77	57

[Note] CB is attached with relevant PIN.

CR Φ32~Φ63

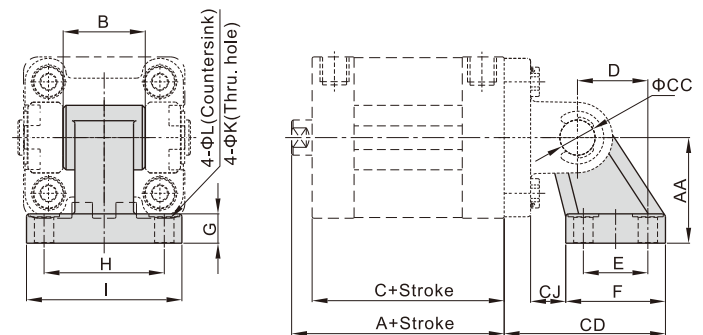

Bore size\Item	A	AA	B	C	CC	CD	CJ	D	E	F	G	H	I	K	L
32	51	32	26	44	10	50	10	21	18	31	8	38	51	6.6	11
40	52.5	36	28	45.5	12	56	12	24	22	35	10	41	54	6.6	11
50	53.5	45	32	45.5	12	68	13	33	30	45	12	50	65	9	14
63	57	50	40	49	16	77	17	37	35	50	12	52	67	9	14

[Note] CR can't be used alone, it must be used with CB.

ISO21287 Compact cylinder

ACF Series—Accessories

SDB $\Phi 12\sim\Phi 25$

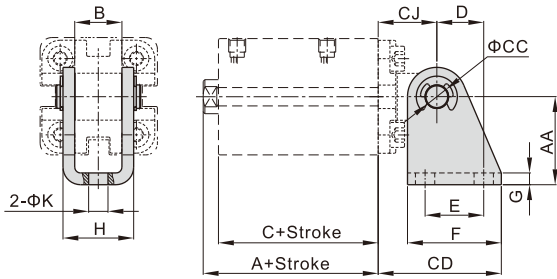

Bore size/Item	A	AA	B	C	CC	CD	CJ	D	E	F	G	H	K
12	40	27	12.1	35	6	34	16	13	15	25	2	18.1	5.5
16	40	27	12.1	35	6	34	16	13	15	25	2	18.1	5.5
20	43	30	16.1	37	8	42	20	16	20	32	2.5	24.1	6.6
25	45	30	16.1	39	8	42	20	16	20	32	2.5	24.1	6.6

[Note] SDB can't be used alone, it must be used with CA.

FTC $\Phi 32\sim\Phi 63$

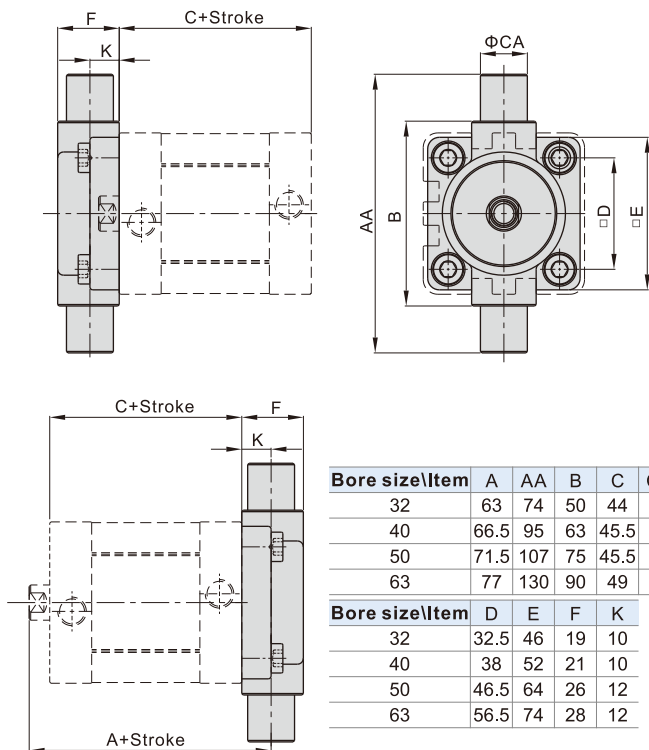

TCM2 $\Phi 32\sim\Phi 63$

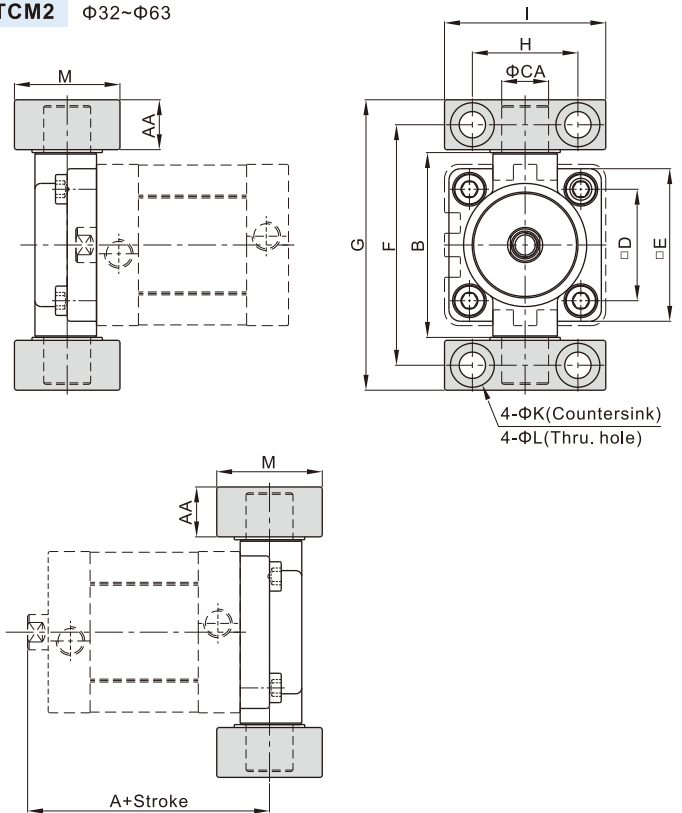

Bore size/Item	A	AA	B	CA	D	E	F	G	H	I	K	L	M
32	63	14	52	12	32.5	46	66	80	32	46	11	7	30
40	66.5	17	65	16	38	52	82	99	36	55	15	9	36
50	71.5	17	75	16	46.5	64	94	111	36	55	15	9	36
63	77	20.5	90	20	56.5	74	113.5	134	42	65	18	11	40

[Note] TCM2 can't be used alone, it must be used with FTC.
The installation position of the accessories can not be adjusted arbitrarily.

I Knuckle F-ACQ12I

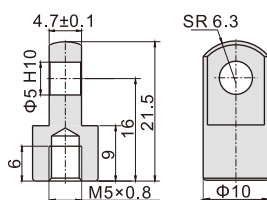

[Note] Other I knuckles are common parts.
Please refer to our catalog for knuckle detail.

Y Knuckle F-ACQ12Y

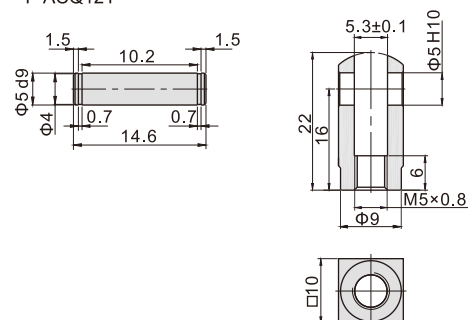

[Note] Other Y knuckles are common parts.
Please refer to our catalog for knuckle detail.