







Tight cylinder—ACP Series

Product series

Series name	Mounting type						Acting type	Bore size	Collocation of sensor switch	
	Basic	FA	FB	CA	CB	LB			CS1-G	DS1-G
Double acting type: ACP 	●	●	●	●	●	●	Double acting	12	●	●
Double rod type: ACPD 	●	●	●	●	●	●		16	●	●
Adjustable stroke type: ACPJ 	●	●	●	●	●	●		20	●	●
Single acting type: ASP, ATP 	●	●	●	●	●	●		25	●	●
	●	●	●	●	●	●		32	●	●
	●	●	●	●	●	●		40	●	●
	●	●	●	●	●	●		50	●	●
	●	●	●	●	●	●		63	●	●
	●	●	●	●	●	●		80	●	●
	●	●	●	●	●	●		100	●	●
Page	268						271		403	



ACP

Installation and application

1. When load changes in the work, the cylinder with abundant output capacity shall be selected.
2. Relative cylinder with high temperature resistance or corrosion resistance shall be chosen under the condition of high temperature or corrosion.
3. Necessary protection measure shall be taken in the environment with higher humidity, much dust or water drops, oil dust and welding dregs.
4. Dirty substances in the pipe must be eliminated before cylinder is connected with pipeline to prevent the entrance of particles into the cylinder.
5. The medium used by cylinder shall be filtered to 40 μm or below.
6. As both of the front cover and piston of the cylinder are short, typically too large stroke can not be selected.
7. Anti-freezing measure shall be adopted under low temperature environment to prevent moisture freezing.
8. The cylinder shall avoid the influence of side load in operation to maintain the normal work of cylinder and extend the service life.
9. If the cylinder is dismantled and stored for a long time, please conduct anti-rust treatment to the surface. Anti-dust caps shall be added in air inlet and outlet ports. The front and back cover can not be dismantled, which shall be especially noticed.

Criteria for selection: Cylinder thrust

Unit: Newton(N)

Bore size (mm)	Rod size (mm)	Acting type	Pressure area (mm ²)	Operating pressure(MPa)							Bore size (mm)	Rod size (mm)	Acting type	Pressure area (mm ²)	Operating pressure(MPa)										
				0.1	0.2	0.3	0.4	0.5	0.6	0.7					0.1	0.2	0.3	0.4	0.5	0.6	0.7				
12	6	Single acting	Push side	131.1	-	6.1	17.4	28.7	40.0	51.4	62.7	40	12	Single acting	Push side	1256.6	54.2	179.8	305.5	431.2	556.8	682.5	808.1		
			Pull side	84.8	-	0.5	8.9	17.4	25.9	34.4	42.9				Pull side	1143.5	42.9	157.2	271.6	385.9	500.3	614.6	729.0		
		Double acting	Push side	131.1	11.3	22.6	33.9	45.2	56.5	67.9	79.2			50	16	Double acting	Push side	1256.6	125.7	251.3	377.0	502.7	628.3	754.0	879.6
			Pull side	84.8	8.5	17.0	25.4	33.9	42.4	50.9	59.4						Pull side	1143.5	114.4	228.7	343.1	457.4	571.8	686.1	800.5
16	8	Single acting	Push side	201.1	-	18.1	38.2	58.3	78.4	98.5	118.6	63	16	Single acting	Push side	1963.5	90.1	286.5	482.8	679.2	875.5	1071.9	1268.2		
			Pull side	150.8	-	8.1	23.1	38.2	53.3	68.4	83.5				Pull side	1762.4	70.0	246.3	422.5	598.8	775.0	951.3	1127.5		
		Double acting	Push side	201.1	20.1	40.2	60.3	80.4	100.5	120.6	140.7			80	20	Double acting	Push side	1963.5	196.3	392.7	589.0	785.4	981.7	1178.1	1374.4
			Pull side	150.8	15.1	30.2	45.2	60.3	75.4	90.5	105.6						Pull side	1762.4	176.2	352.5	528.7	705.0	881.2	1057.5	1233.7
20	10	Single acting	Push side	314.2	-	33.1	64.5	96.0	127.4	158.8	190.2	100	25	Single acting	Push side	3117.2	173.6	485.3	797.1	1108.8	1420.5	1732.2	2044.0		
			Pull side	235.6	-	17.4	41.0	64.5	88.1	111.7	135.2				Pull side	2916.2	153.5	445.1	736.8	1028.4	1320.0	1611.6	1903.2		
		Double acting	Push side	314.2	31.4	62.8	94.2	125.7	157.1	188.5	219.9			80	20	Double acting	Push side	3117.2	311.7	623.4	935.2	1246.9	1558.6	1870.3	2182.1
			Pull side	235.6	23.6	47.1	70.7	94.2	117.8	141.4	164.9						Pull side	2916.2	291.6	583.2	874.9	1166.5	1458.1	1749.7	2041.3
25	10	Single acting	Push side	490.9	13.8	62.9	112.0	161.0	210.1	259.2	308.3	100	25	Single acting	Push side	5026.5	305.6	808.2	1310.9	1813.5	2316.2	2818.8	3321.5		
			Pull side	412.3	5.9	47.2	88.4	129.6	170.9	212.1	253.3				Pull side	4712.4	274.1	745.4	1216.6	1687.9	2159.1	2630.3	3101.6		
		Double acting	Push side	490.9	49.1	98.2	147.3	196.3	245.4	294.5	343.6			80	20	Double acting	Push side	5026.5	502.7	1005.3	1508.0	2010.6	2513.3	3015.9	3518.6
			Pull side	412.3	41.2	82.5	123.7	164.9	206.2	247.4	288.6						Pull side	4712.4	471.2	942.5	1413.7	1885.0	2356.2	2827.4	3298.7
32	12	Single acting	Push side	804.2	30.8	111.2	191.7	272.1	352.5	432.9	513.4	100	25	Single acting	Push side	7854.0	499.1	1284.5	2069.9	2855.3	3640.7	4426.1	5211.5		
			Pull side	691.2	19.5	88.6	157.7	226.9	296.0	365.1	434.2				Pull side	7363.1	450.0	1186.3	1922.6	2658.9	3395.3	4131.6	4867.9		
		Double acting	Push side	804.2	80.4	160.8	241.3	321.7	402.1	482.5	563.0			80	20	Double acting	Push side	7854.0	785.4	1570.8	2356.2	3141.6	3927.0	4712.4	5497.8
			Pull side	691.2	69.1	138.2	270.3	350.7	431.1	511.5	592.0						Pull side	7363.1	736.3	1472.6	2208.9	2945.2	3681.6	4417.9	5154.2



Tight cylinder

ACP Series



Symbol

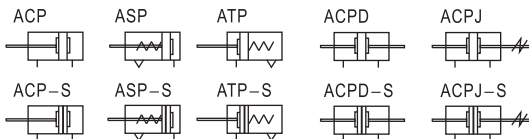

Product feature

1. DIN standard cylinder.
2. The cylinder body connects with the threads of the front and back cover, forming high strength and convenient maintenance.
3. The internal diameter of the body is treated with rolling followed by the treatment of hard anodizing, forming an excellent abrasion resistance and durability
4. The seal of piston adopts heterogeneous two-way seal structure. It has compact dimension and the function of oil reservation.
5. Compact structure can effectively save installation space.
6. There are magnetic switch slots around the cylinder body, which is convenient to install inducting switch.
7. Installing accessories with various specifications are optional.

Ordering code

Model can be changed Ordering code. Example:

Production type: ACPJ
Magnet: With magnet
Bore size: 50mm
Stroke: 80mm
Adjustable stroke: 50mm
Rod type: Male thread
Mounting type: LB
Thread type: NPT

Model: ACPJ S-50 × 80-50-B-LB-T

Ordering code: ACPJ S 50 0080 050 B LB T

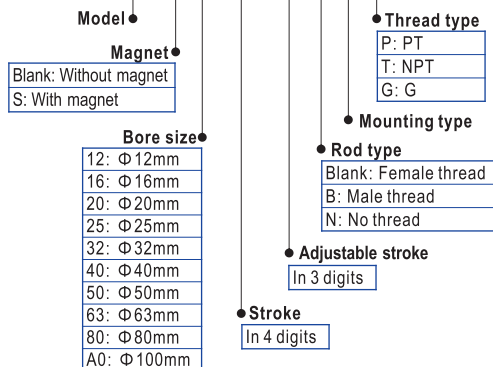

Specification

Bore size(mm)	12	16	20	25	32	40	50	63	80	100
Acting type	Double acting, Single acting-Push type, Single acting-Pull type									
Fluid	Air(to be filtered by 40 μ m filter element)									
Operating pressure	Double acting	0.1~1.0MPa(15~145psi)(1.0~10.0bar)								
	Single acting	0.2~1.0MPa(28~145psi)(2.0~10.0bar)								
Proof pressure	1.5MPa(215psi)(15bar)									
Temperature °C	-20~80									
Speed range mm/s	Double acting: 30~500					Single acting: 50~500				
Stroke tolerance	0~150 ^{+1.0} ₀					>150 ^{+1.4} ₀				
Cushion type	Bumper									
Port size ①	M5 × 0.8					1/8"			1/4"	

① PT thread, NPT thread and G thread are available. Add) Refer to P403~426 for detail of sensor switch.

Stroke

Bore size (mm)		Standard stroke (mm)										Max. std stroke	Max. stroke										
		5	10	15	20	25	30	35	40	45	50			55	60	65	70	75	80	85	90	95	100
12	Double acting	120 125 150 160 175 200																				200	200
	Single acting	5 10																					
16	Double acting	120 125 150 160 175 200																				200	200
	Single acting	5 10 15 20 25																					
20	Double acting	120 125 150 160 175 200 225 250 275 300																				300	300
	Single acting	5 10 15 20 25																					
25	Double acting	120 125 150 160 175 200 225 250 275 300																				300	300
	Single acting	5 10 15 20 25																					
32	Double acting	120 125 150 160 175 200 225 250 275 300																				300	300
	Single acting	5 10 15 20 25																					
40	Double acting	120 125 150 160 175 200 225 250 275 300																				300	300
	Single acting	5 10 15 20 25																					
50	Double acting	120 125 150 160 175 200 225 250 275 300																				300	300
	Single acting	5 10 15 20 25																					
63	Double acting	120 125 150 160 175 200 225 250 275 300																				300	300
	Single acting	5 10 15 20 25																					
80	Double acting	120 125 150 160 175 200 225 250 275 300																				300	300
	Single acting	5 10 15 20 25																					
100	Double acting	120 125 150 160 175 200 225 250 275 300																				300	300
	Single acting	5 10 15 20 25																					

Note) 1. Please contact the company for other special strokes.

2. The dimensions of non-std stroke cylinder has the same dimensions as the next longer stroke std. stroke cylinder. e.g. 23mm stroke cylinder has the same dimensions of 25 std. stroke cylinder.

Explain of model

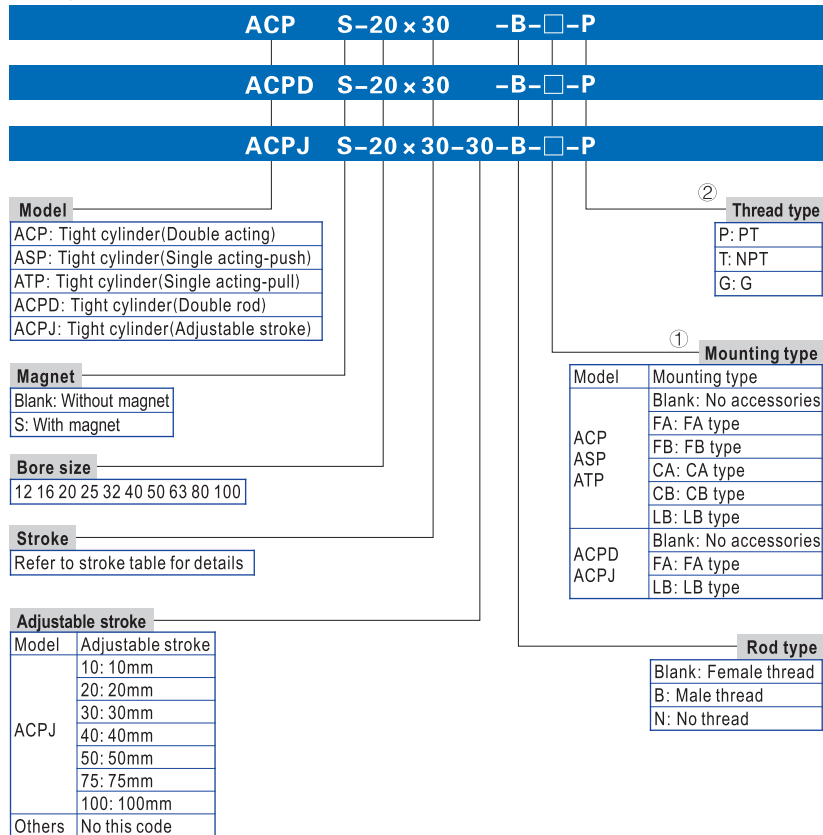

① Please refer to page 271 for accessory parts.

② Standard thread is blank here.



Tight cylinder

ACP Series



Inner structure and material of major parts

ACP-S

NO.	Item	Material	
1	Body	Aluminum alloy	
2	Screw	Carbon steel	
3	Piston rod	Φ 12-25 Others	Stainless steel S45C
4	O-ring	NBR	
5	Piston	Aluminum alloy	
6	Back cover	Aluminum alloy	
7	Magnet holder	Aluminum alloy	
8	Bumper	TPU	
9	Magnet	Φ 12-32 Others	Sintered metal (Neodymium-iron-boron) Plastic
10	O-ring	NBR	
11	Wear ring	Φ 12-32 Others	No Wear resistant material
12	Piston seal	NBR	
13	Front cover	Aluminum alloy	
14	Bushing	Φ 12-20 Others	No Wear resistant material
15	Front cover packing	NBR	

Dimensions

ACP

ASP

ATP

Mounting groove for sensor switch
Φ 12-25: One groove on three sides
The others: Two grooves on three sides

Bore size\Item	A	B	C	D	E	F	G	H	I	J	K	L	M	N	O	P	Q	Q1	R	R1
12	6	4	30	18	29	7	M5 × 0.8	3	6	M4 × 0.7	11.5	18	38	42.5	4.5	5	M3 × 0.5	3.3	8	1.5
16	6	4	30	18	29	7	M5 × 0.8	3	8	M4 × 0.7	11.5	18	38	42.5	4.5	6	M4 × 0.7	4.5	10	1.5
20	6	4	37.5	22	36	7	M5 × 0.8	3	10	M5 × 0.8	11.5	18	38	42.5	4.5	8	M5 × 0.8	5.5	12	2
25	6.1	4	41.5	26	40	7	M5 × 0.8	4	10	M5 × 0.8	11.5	18	39.5	45	5.5	8	M5 × 0.8	5.5	12	2
32	6.1	4	52	32	50	8	1/8"	4.5	12	M6 × 1.0	14	21	44.5	50.5	6	10	M6 × 1.0	6.5	14	2.6
40	6.1	4	62.5	42	60	8	1/8"	4.5	12	M6 × 1.0	14	21	45.5	52	6.5	10	M6 × 1.0	6.5	14	2.6
50	6.1	4	71	50	68	8	1/8"	5	16	M8 × 1.25	14	21.5	45.5	53	7.5	13	M8 × 1.25	8.5	16	3.3
63	8.1	4	91	62	87	8	1/8"	5	16	M10 × 1.5	15	24	50	57.5	7.5	13	M8 × 1.25	8.5	16	3.3
80	8.1	4	111	82	107	8.5	1/8"	5.5	20	M10 × 1.5	16	27	56	64	8	17	M10 × 1.5	10.5	20	4.7
100	8.1	4	133	103	128	10.5	1/4"	7.5	25	M10 × 1.5	19	32	66.5	76.5	10	22	M12 × 1.75	12.5	24	6.1

Remark: The dimensions of magnet type cylinder are the same as non-magnet type cylinder.



Tight cylinder

ACP Series



ACP-B

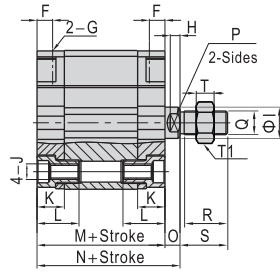
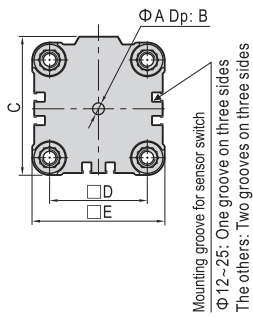

ACPD

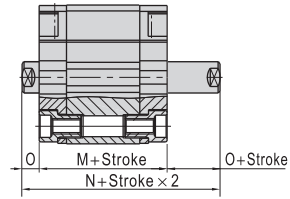

ASP-B

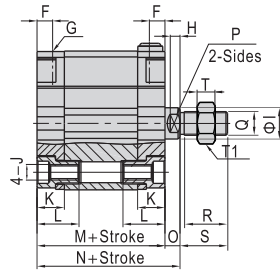
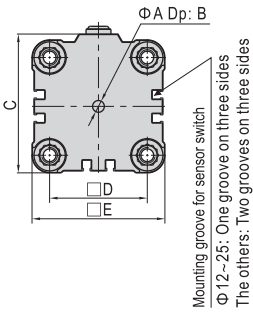

ACPJ

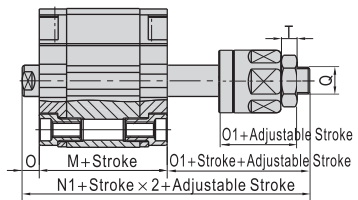

ACP

ATP-B

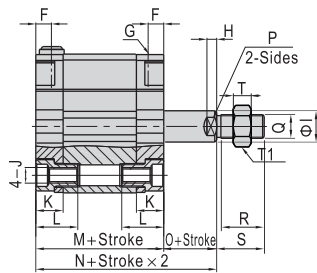
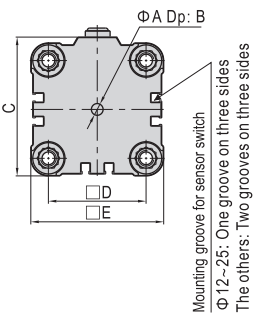

Bore size\Item	M	N	N1	O	O1	T	Q
12	38	47	63.5	4.5	21	5	M6 × 1.0
16	38	47	67.5	4.5	25	6	M8 × 1.25
20	38	47	69.5	4.5	27	6	M10 × 1.25
25	39.5	50.5	72	5.5	27	6	M10 × 1.25
32	44.5	56.5	77.5	6	27	6	M10 × 1.25
40	45.5	58.5	79	6.5	27	6	M10 × 1.25
50	45.5	60.5	81	7.5	28	7	M12 × 1.25
63	50	65	85.5	7.5	28	7	M12 × 1.25
80	56	72	93	8	29	8	M16 × 1.5
100	66.5	86.5	112	10	35.5	10	M20 × 1.5

Remark:

1. The dimensions of magnet type cylinder are the same as non-magnet type cylinder.
2. Please refer to this page for male thread dimensions.
3. The unmarked dimension is the same as ACP standard type.

Bore size\Item	A	B	C	D	E	F	G	H	I	J
12	6	4	30	18	29	7	M5 × 0.8	3	6	M4 × 0.7
16	6	4	30	18	29	7	M5 × 0.8	3	8	M4 × 0.7
20	6	4	37.5	22	36	7	M5 × 0.8	3	10	M5 × 0.8
25	6.1	4	41.5	26	40	7	M5 × 0.8	4	10	M5 × 0.8
32	6.1	4	52	32	50	8	1/8"	4.5	12	M6 × 1.0
40	6.1	4	62.5	42	60	8	1/8"	4.5	12	M6 × 1.0
50	6.1	4	71	50	68	8	1/8"	5	16	M8 × 1.25
63	8.1	4	91	62	87	8	1/8"	5	16	M10 × 1.5
80	8.1	4	111	82	107	8.5	1/8"	5.5	20	M10 × 1.5
100	8.1	4	133	103	128	10.5	1/4"	7.5	25	M10 × 1.5

Bore size\Item	K	L	M	N	O	P	Q	R	S	T	T1
12	11.5	18	38	42.5	4.5	5	M6 × 1.0	15	16	5	10
16	11.5	18	38	42.5	4.5	6	M8 × 1.25	19	20	6	12
20	11.5	18	38	42.5	4.5	8	M10 × 1.25	20	22	6	17
25	11.5	18	39.5	45	5.5	8	M10 × 1.25	20	22	6	17
32	14	21	44.5	50.5	6	10	M10 × 1.25	20	22	6	17
40	14	21	45.5	52	6.5	10	M10 × 1.25	20	22	6	17
50	14	21.5	45.5	53	7.5	13	M12 × 1.25	22	24	7	17
63	15	24	50	57.5	7.5	13	M12 × 1.25	22	24	7	17
80	16	27	56	64	8	17	M16 × 1.5	30	32	8	23
100	19	32	66.5	76.5	10	22	M20 × 1.5	38	40	10	26

Remark: The dimensions of magnet type cylinder are the same as non-magnet type cylinder.



Tight cylinder



Accessories

Ordering code

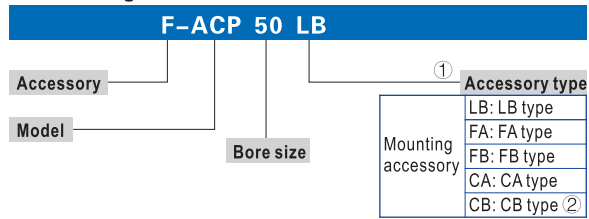

- ① Please refer to accessory list for selection and ordering information.
- ② CB is attached with relevant PIN.

Accessory selection

Accessories		Mounting accessory				
Cylinder model		LB	FA	FB	CA	CB
ACP		●	●	●	●	●
ASP		●	●	●	●	●
ATP		●	●	●	●	●
ACPD		●	●	×	×	×
ACPJ		●	●	×	×	×

Accessories		Knuckle ①		Sensor switch ②	
Cylinder model		F	U	CS1-G	DS1-G
ACP	Female thread	×	×	×	×
	With magnet	×	×	●	●
Male thread	Standard	●	●	×	×
	With magnet	●	●	●	●
ASP	Female thread	×	×	×	×
	With magnet	×	×	●	●
Male thread	Standard	●	●	×	×
	With magnet	●	●	●	●
ACPD	Female thread	×	×	×	×
	With magnet	×	×	●	●
ACPJ	Male thread	●	●	×	×
	With magnet	●	●	●	●

- ① Please refer to P397~402 for knuckle detail.
- ② Please refer to P403~426 for detail of sensor switch.

Material of accessories

Bore size	Mounting accessories					Knuckle	
	LB	FA	FB	CA	CB	F	U
12	○	●	●	●	×	□	□
16	○	●	●	●	×	□	□
20	○	●	●	●	×	□	□
25	○	●	●	●	×	□	□
32	○	●	●	×	●	□	□
40	○	●	●	×	●	□	□
50	○	●	●	×	●	□	□
63	○	●	●	×	●	□	□
80	○	●	●	×	●	□	□
100	○	●	●	×	●	□	□

- — Aluminum alloy, × — Without this type,
- — SPCC, □ — Carbon steel.

Dimensions

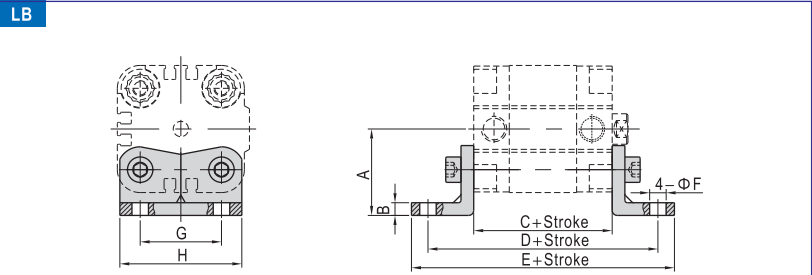

Bore size\Item	A	B	C	D	E	F	G	H
12	22	3	38	64	73.6	5.5	18	27
16	22	3	38	64	73.6	5.5	18	27
20	27	3.8	38	70	82.6	6.5	22	34
25	29	3.8	39.5	71.5	84	6.5	26	38
32	34	4.8	44.5	80.5	97.1	6.5	32	48
40	40.5	4.8	45.5	85.5	102.1	9	42	58
50	47	5.8	45.5	93.5	110.1	9	50	66
63	56.5	5.8	50	104	127.6	11	62	85
80	68.5	7.5	56	116	139.6	11	82	105
100	81	7.5	66.5	132.5	156.1	13.5	103	126

FA, FB

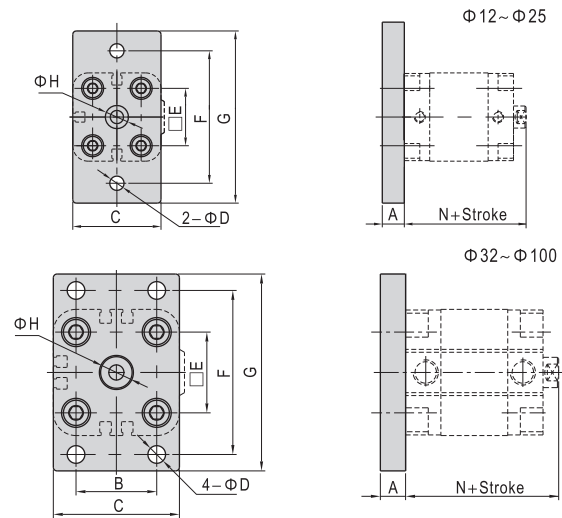

Bore size\Item	A	B	C	D	E	F	G	H	N
12	10	-	30	5.5	18	43	55	14	42.5
16	10	-	30	5.5	18	43	55	14	42.5
20	10	-	36	6.5	22	55	68	16	42.5
25	10	-	40	6.5	26	60	78	16	45
32	10	32	50	7	32	65	78	18	50.5
40	10	36	60	9	42	82	102	18	52
50	12	45	68	9	50	90	110	22	53
63	15	50	87	9	62	110	128	22	57.5
80	15	63	107	12	82	135	160	28	64
100	15	75	128	14	103	163	190	34	76.5



ACP

Tight cylinder

Accessories

CA

Φ 12~Φ 25

CB

Φ 32~Φ 100

Bore size\Item	A	B	C	D	E	F	G	H	N
12	16	22	6	-	18	12	27.5	-	42.5
16	16	22	6	-	18	12	27.5	-	42.5
20	20	28	8	-	22	16	34.5	-	42.5
25	20	28	8	-	26	16	38.5	-	45
32	22	32	10	26	32	45	48	51.5	50.5
40	25	37	12	28	42	52	58	59	52
50	27	39	12	32	50	60	66	67	53
63	32	48	16	40	62	70	85	77	57.5
80	36	52	16	50	82	90	105	97	64
100	41	61	20	60	103	110	126	119	76.5



List for ordering code of accessories

Bore size	Accessories		Mounting accessory		
	LB	FA	FB	CA	CB
12	F-ACP12LB	F-ACP12FA	F-ACP12FA	F-ACP12CA	-
16	F-ACP12LB	F-ACP12FA	F-ACP12FA	F-ACP12CA	-
20	F-ACP20LB	F-ACP20FA	F-ACP20FA	F-ACP20CA	-
25	F-ACP25LB	F-ACP25FA	F-ACP25FA	F-ACP25CA	-
32	F-ACP32LB	F-ACP32FA	-	-	F-ACP32CB
40	F-ACP40LB	F-ACP40FA	-	-	F-ACP40CB
50	F-ACP50LB	F-ACP50FA	-	-	F-ACP50CB
63	F-ACP63LB	F-ACP63FA	-	-	F-ACP63CB
80	F-ACP80LB	F-ACP80FA	-	-	F-ACP80CB
100	F-ACP100LB	F-ACP100FA	-	-	F-ACP100CB

Bore size	Accessories		Knuckle		Sensor switch
	F: F Knuckle	U: U Knuckle	F: F Knuckle	U: U Knuckle	
12	-	-	F-M06100U	-	CS1-G DS1-G
16	F-M08125F	-	F-M08125U	-	
20	-	-	-	-	
25	F-M10125F	-	F-M10125U	-	
32	-	-	-	-	
40	-	-	-	-	
50	F-M12125F	-	F-M12125U	-	
63	-	-	-	-	
80	F-M16150F	-	F-M16150U	-	
100	F-M20150F	-	F-M20150U	-	

