

# Parallel Gripper with dust-proof cover and roller bearing style **AirTAC**

## HFKP Series



### Specification

Bore size (mm)	16	20	25	32
Acting type	Double acting			
Fluid	Air(to be filtered by 40 μm filter element)			
Operating pressure	0.15~0.7MPa(22~100psi)(1.5~7.0bar)			
Temperature °C	-20~70			
Lubrication	Not required			
Repeatability mm	±0.01			±0.02
Max. frequency	180(c.p.m)			60(c.p.m)
Sensor switches	CMSH、DMSH、EMSH、CMSG、DMSG、EMSG			
Port size	M5×0.8			

Note) Refer to P362 for detail of sensor switch.

### Gripping force and stroke

Bore size		16	20	25	32
Gripping force per finger Effective value(N)	Closed	30	42	65	158
	open	40	66	104	193
Opening/Closing stroke(Both sides)(mm)		6	10	14	22
Weight (g)		130	251	475	792

[Note] The gripping force in the above table is at working pressure of 0.5MPa, and with a gripping point of L=20mm.

Add) Please refer to page 287 for the definition of "L".

### Symbol

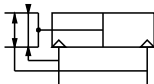

### Ordering code

**HFKP 32** □

① ② ③

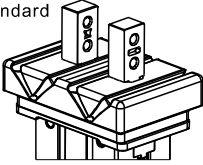
① Model	② Bore size	③ Finger type
HFKP: Parallel Gripper with dust-proof cover and roller bearing style(Double acting)	16 20 25 32	Blank: Standard 

[Note]:HFKP series are all standard come with magnet. (not includes sensor)

### Inner structure and material of major parts

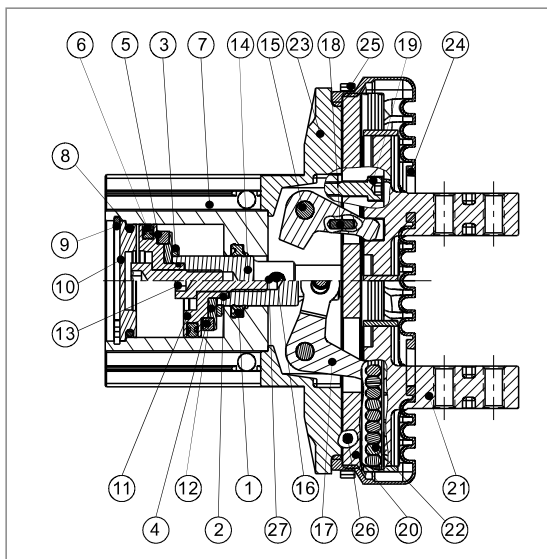

NO.	Item	Material	NO.	Item	Material
1	Rod packing	NBR	15	Pin	Stainless steel
2	O-ring	NBR	16	Pin	Stainless steel
3	Bumper	TPU	17	Curved bar	Stainless steel
4	Magnet	Neodymium-iron-boron	18	Pin	Bearing steel
5	Magnet washer	NBR	19	Countersink screw	Alloy steel
6	Piston seal	NBR	20	Guide roller	Alloy steel
7	Body	Aluminum alloy	21	Clamping jaw	Bearing steel
8	O-ring	NBR	22	Guide rail	Bearing steel
9	C clip	Spring steel	23	Dustproof cover ring	Resin
10	Back cover	Aluminum alloy	24	Dustproof cover	NBR
11	Piston	Aluminum alloy	25	Fixed rod	Cold rolled sheet
12	Magnet fixed flake	Aluminum alloy /Stainless steel	26	Screw	Alloy steel
13	Countersink screw	Alloy steel	27	Pin bushing	Stainless steel
14	Piston rod	Aluminum alloy/Stainless steel			

[Note]: No. 25 and No. 26 in the above table are only for HFKP32.



# Parallel Gripper with dust-proof cover and roller bearing style **AirTAC**

## HFKP Series

### Dimensions

#### HFKP16

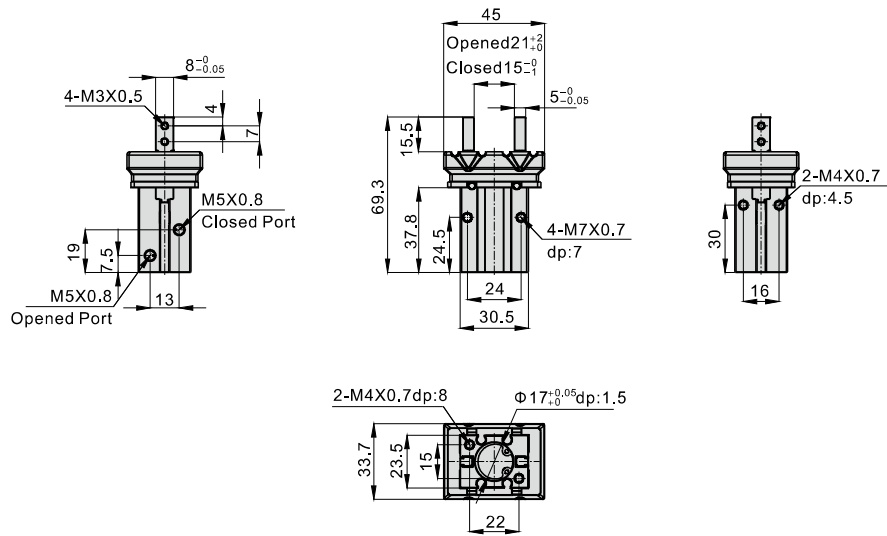

#### HFKP20

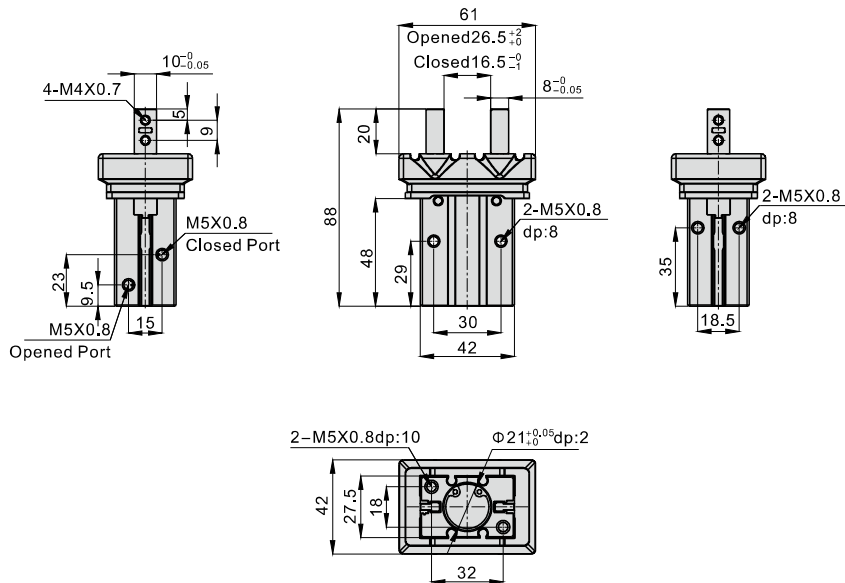

# Parallel Gripper with dust-proof cover and roller bearing style **AirTAC**

## HFKP Series

### HFKP25

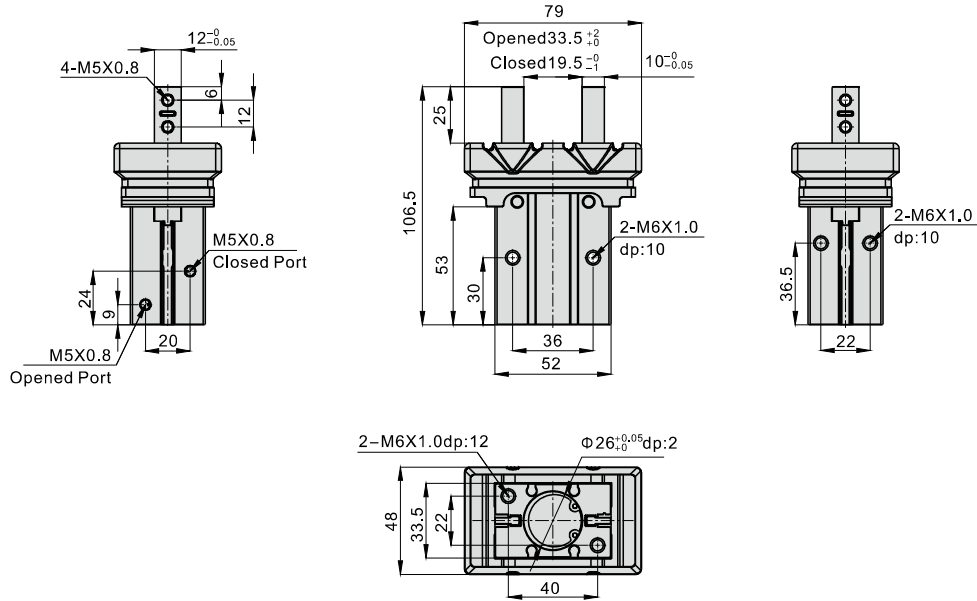

### HFKP32

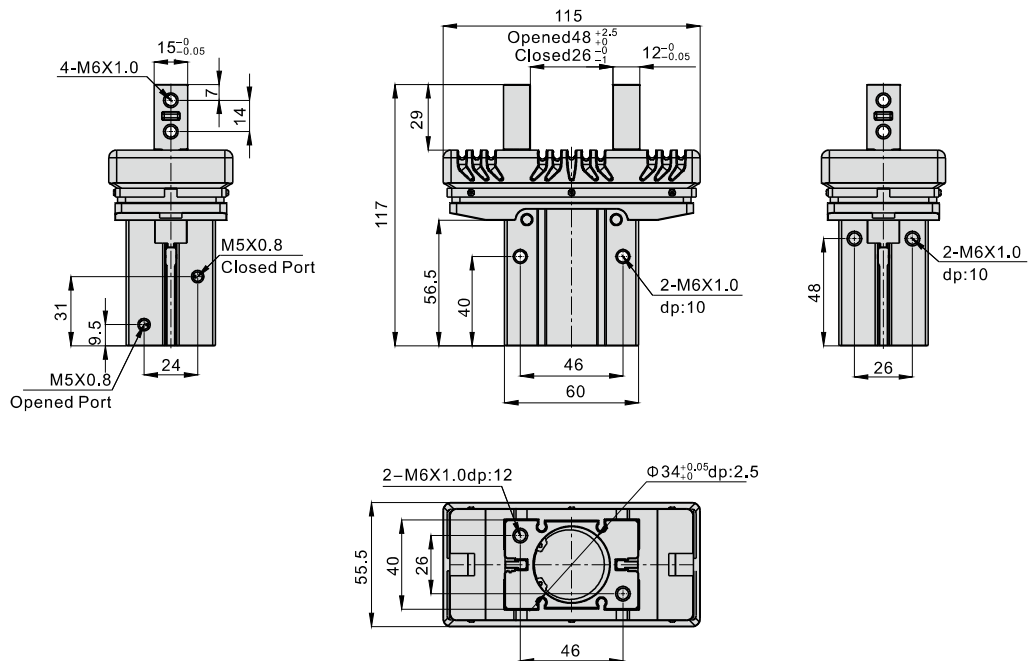

# Parallel Gripper with dust-proof cover and roller bearing style **AirTAC**

## HFKP Series

### How to select product

Please select pneumatic finger according to the following steps:

① The selection of the effective gripping force

② the confirmation of the gripping point

③ the confirmation of the external force put on the gripping jaw

#### 1. The selection of the gripping force

The gripping work-pieces shown below, on the impact condition of ordinary handling state, taking safety coefficient  $a=4$ , have a gripping force that is more than 10-20 times of the mass of the gripped objects.

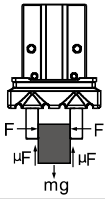

The work-pieces as shown in the left :

F: Gripping force (N)  
 $\mu$ : friction coefficient between fittings and work-pieces.  
 m: mass of work-pieces  
 g: acceleration of gravity ( $=9.8m/s^2$ )

The condition that the work-pieces won't drop is:  $2 \times \mu F > mg$

$$\text{so: } F > \frac{mg}{2 \times \mu}$$

Safety coefficient is a, so F is:

$$F = \frac{mg}{2 \times \mu} \times a$$

$$\mu = 0.2$$

$$F = \frac{mg}{2 \times 0.2} \times 4 = 10 \times mg$$

10 times of the mass of the gripped objects

$$\mu = 0.1$$

$$F = \frac{mg}{2 \times 0.1} \times 4 = 20 \times mg$$

20 times of the mass of the gripped objects

Note) If the friction coefficient  $\mu > 0.2$ , for safety, please also select clamping force according to the principle of 10~20 times of the mass of the clamped objects. As for large acceleration and shock, it requires for greater safety coefficient.

1.1) The actual gripping force must be within the effective gripping forces of different pneumatic fingers specifications shown in the below chart.

#### Closed gripping force

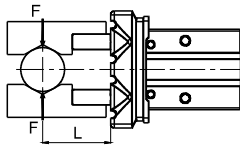

#### Opened gripping force

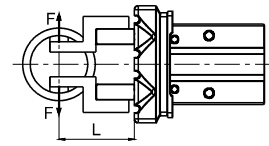

HFKP16

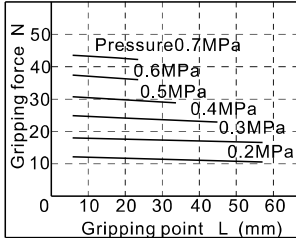

HFKP25

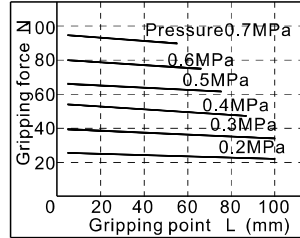

HFKP16

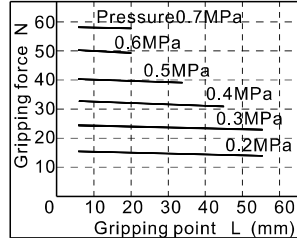

HFKP25

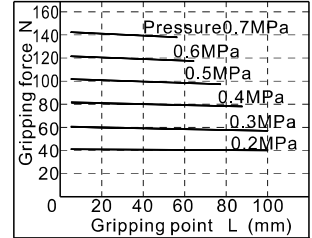

HFKP20

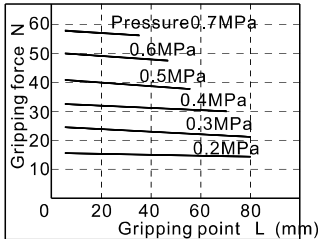

HFKP32

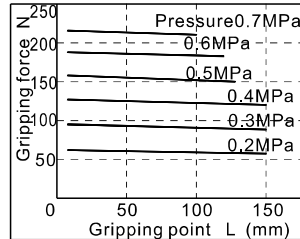

HFKP20

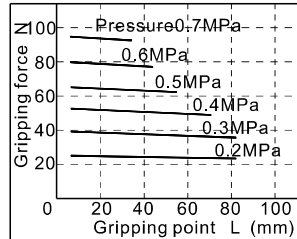

HFKP32

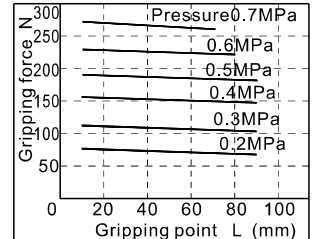

# Parallel Gripper with dust-proof cover and roller bearing style **AirTAC**

## HFKP Series

### 2. The selection of the gripping point

2.1) Please select the gripping point within the limited field shown below.

Over the limits, gripping jaws would be subjected to excessive torque loads, and lead to short life of the air gripper.

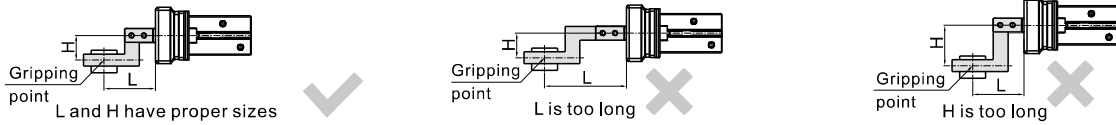

2.2) In the allowable range of gripping point, it is better to design for short and light fittings. If the fittings are long and heavy, the inertia force when the finger is open and close will become larger, and the performance of gripping jaw will be degraded, at the same time it will affect the life.

2.3) When the gripped object is very fine and thin, you have to equip with gap between fittings. If not, there will be unstable clamp, resulting in a position offset and adverse clamping and so on.



### 3. The confirmation of the external force put on the gripping jaw.

Bore size	The allowed vertical loads Fv(N)	Max. permissible torque(Nm)			The calculation of allowable forces when moment loads work	Examples of calculation
		Mp	My	Mr		
16	147	0.68	0.68	1.36	Allowable load(N) $\frac{M(\text{Maximum permissible moment})(\text{N.m})}{L \times 10^{-3}}$ Unit conversion constant	In the guide rail of HFKP16, the external force of the pitching moment static loads put on the point of L=30mm is f=10 N, Allowable load F = 0.68/(30×10 <sup>-3</sup> ) = 22.7(N) Actual load f=10(N)<22.7(N) To meet the using requirements
20	221	1.32	1.32	2.65		
25	382	1.94	1.94	3.88		
32	514	3	3	6		

[Note] The loads and torque values of said are all static values.

#### Closed gripping points

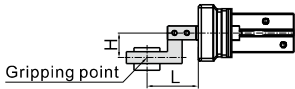

#### Opened clamping point

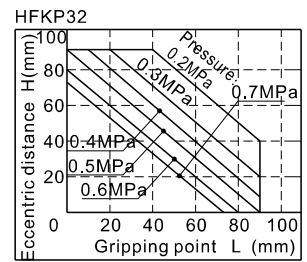
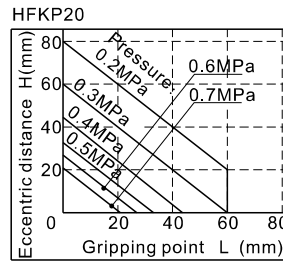
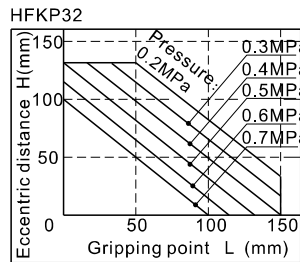
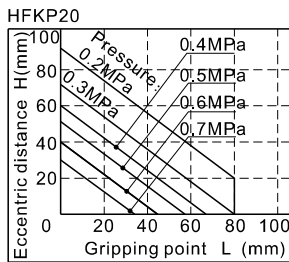
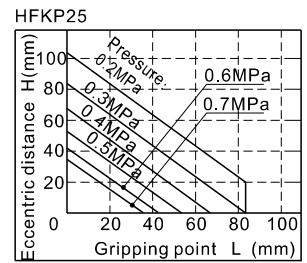
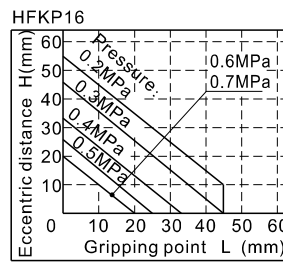
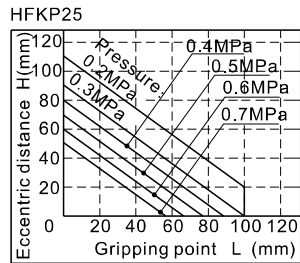
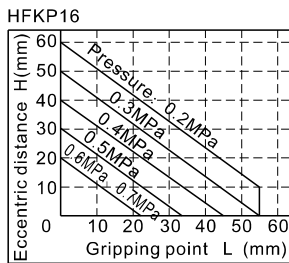
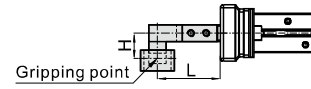

# Parallel Gripper with dust-proof cover and roller bearing style **AirTAC**

## HFKP Series

### Installation and application

- Due to the abrupt changes, the circuit pressure is low, which will lead to the decrease of the gripping force and falling of the work-pieces. In order to avoid the harm to the human body and damage to the equipment, anti-dropping device must be equipped.
- Don't use the air gripper under strong external force and impact force.
- When install and fix the air gripper, avoid falling down, collision and damage.
- When fixing the gripping jaw parts, don't twist the gripping jaw.
- There are several kinds of installation method, and the locking torque of fastening screw must be within the prescribed torque range shown in the below chart. If the locking torque is too large, it will cause the dysfunctional. If the locking torque is too small, it will cause the position deviation and fall.

#### Tail installation type

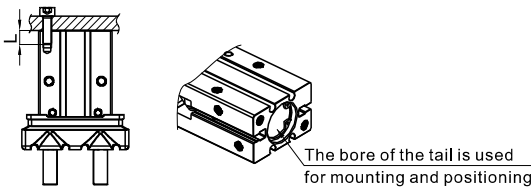

Bore size	The bolts type	Max. locking moment	Max. screwed depth	The aperture of the positioning bore	The depth of the positioning bore
16	M4×0.7	2.1N.m	8mm	Φ17mm <sup>+0.05</sup> <sub>0</sub>	1.5mm
20	M5×0.8	4.3N.m	10mm	Φ21mm <sup>+0.05</sup> <sub>0</sub>	2mm
25	M6×1.0	7.3N.m	12mm	Φ26mm <sup>+0.05</sup> <sub>0</sub>	2mm
32	M6×1.0	7.9N.m	12mm	Φ34mm <sup>+0.05</sup> <sub>0</sub>	2.5mm

#### The installation of the front threaded hole

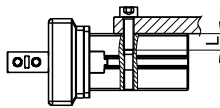

Bore size	The bolts type	Max. locking moment(Nm)	Max. screwed depth(mm)
16	M4×0.7	2.1	7
20	M5×0.8	4.3	8
25	M6×1.0	7.3	10
32	M6×1.0	7.9	10

#### The installation of the front through hole

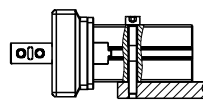

Bore size	The bolts type	Max. locking moment(Nm)	Max. screwed depth(mm)
16	M3×0.5	0.88	8
20	M4×0.7	2.1	10
25	M5×0.8	4.3	12
32	M5×0.8	4.3	13

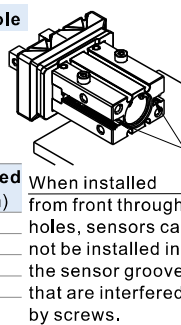

#### Surface installation type

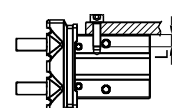

Bore size	The bolts type	Max. locking moment(Nm)	Max. screwed depth(mm)
16	M4×0.7	1.6	4.5
20	M5×0.8	3.3	8
25	M6×1.0	5.9	10
32	M6×1.0	5.9	10

- The installation method of the gripping jaw fittings  
When install the gripping jaw fittings, you have to pay particular attention that you can only hold the gripping jaw by using spanner, and then lock the screws with allen wrench. Never clamp the body directly and then lock the screws, otherwise the parts will be easily damaged.

Bore size	The bolts type	Max. locking moment(Nm)
16	M3×0.5	0.59
20	M4×0.7	1.4
25	M5×0.8	2.8
32	M6×1.0	4.9

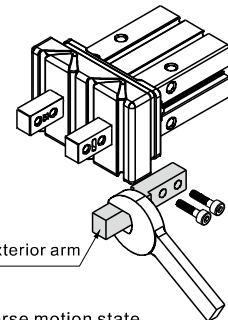

- Confirm that there is no external forces exerted on the gripping jaw.

Transverse load acts on the gripping jaw, which will cause impact load and leads to the shaking and damage of gripping jaw. Equip with gaps so that the air gripper will not crash into work-pieces and accessories at the end of its trip.

- 7.1) The end of stroke under the open state of air gripper

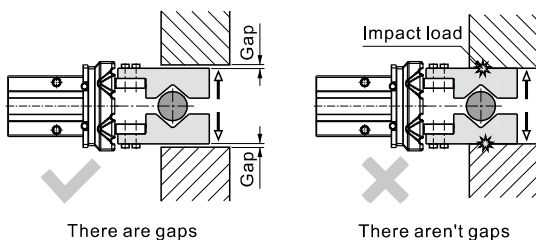

- 7.2) The end of stroke under the move state of air gripper

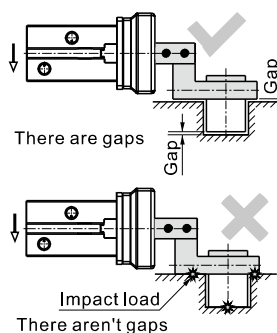

- 7.3) Reverse motion state

When reverse motion state, the gripping point must be precision, otherwise in the reverse motion state the air gripper maybe impact with ambience and will cause impact load.

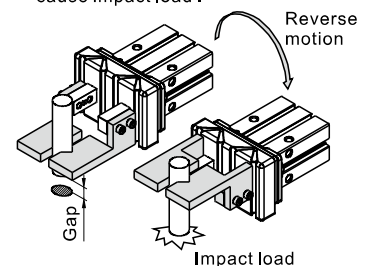

8. When the work-pieces are inserted, the center line should be coaxial, no offset, in case there are external force generated on gripping jaw. When testing, it is specially required that the manual operation should be reduced, the pressure should be used to run it at a low speed, and guarantee the safety and no impact.



9. Please use the flow control valve to adjust the opening and closing speed of gripping jaw if too fast.
10. People can not enter the movement path of air gripper and articles can not be placed on the path too.
11. Before removing the air gripper, please confirm that it is out of working state, and then discharge of compressed air.

