

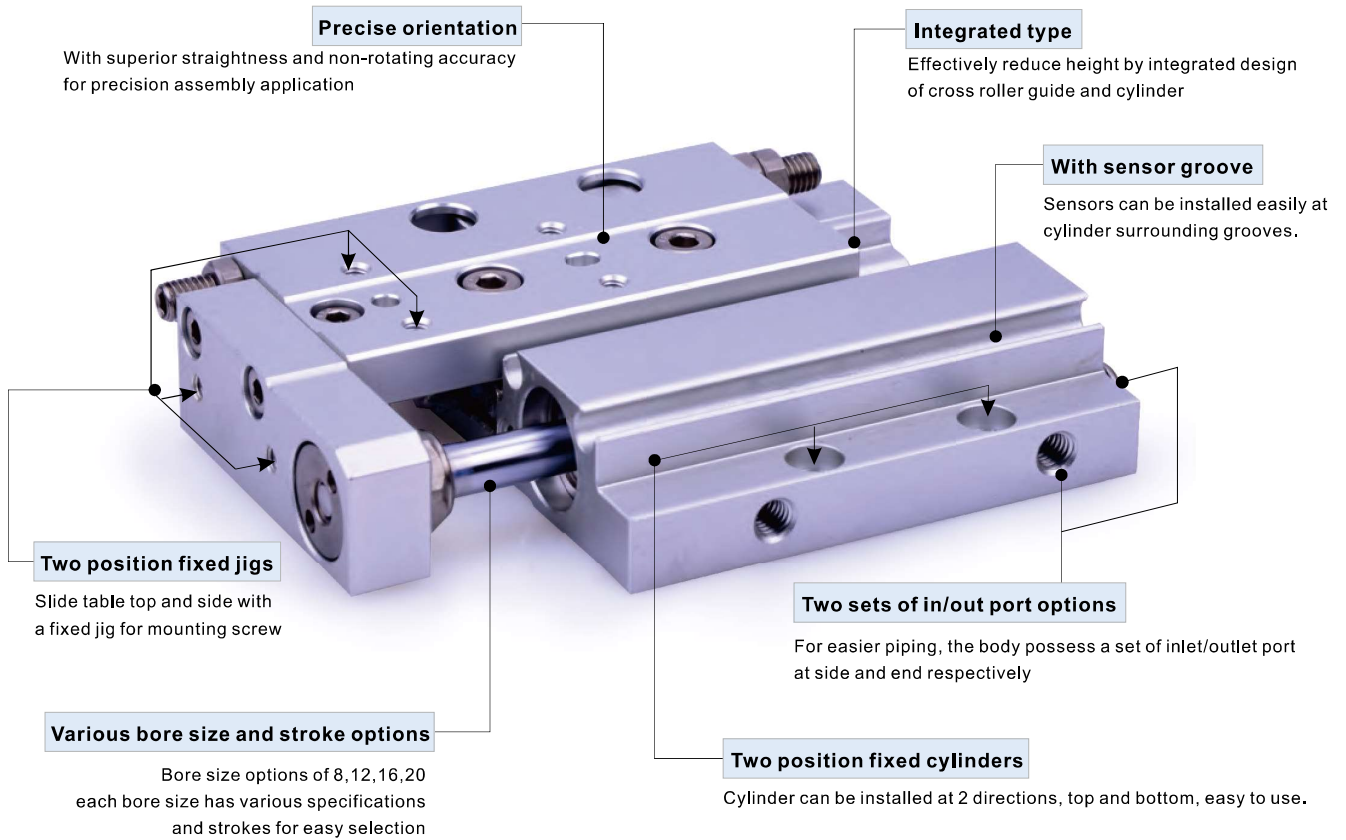

Slide table cylinder—HLF Series

Compendium of HLF Series



Criteria for selection: Cylinder thrust

Unit : Newton(N)

Bore size	Rod size	Acting type	Pressure area(mm ²)	Operating pressure(MPa)						
				0.1	0.2	0.3	0.4	0.5	0.6	0.7
8	3	Double acting Push-side	50.3	5.0	10.1	15.1	20.1	25.1	30.2	35.2
		Pull-side	43.2	4.3	8.6	13.0	17.3	21.6	25.9	30.2
12	4	Double acting Push-side	113.1	11.3	22.6	33.9	45.2	56.5	67.9	79.2
		Pull-side	100.5	10.1	20.1	30.2	40.2	50.3	60.3	70.4
16	6	Double acting Push-side	201.0	20.1	40.2	60.3	80.4	100.5	120.6	140.7
		Pull-side	172.7	17.3	34.5	51.8	69.1	86.4	103.6	120.9
20	8	Double acting Push-side	314.0	31.4	62.8	94.2	125.6	157.0	188.4	219.8
		Pull-side	263.8	26.4	52.8	79.1	105.5	131.9	158.3	184.7

Installation and application



1. Dirty substances in the pipe must be eliminated before cylinder is connected with pipeline to prevent the entrance of impurities into the cylinder.
2. The medium used by cylinder should be filtered to 40μm or below.
3. Anti-freezing measure shall be adopted under low temperature environment to prevent moisture freezing.
4. If the cylinder is dismantled and stored for a long time, pay attention to conduct anti-rust treatment to the surface. Anti-dust caps shall be added in air inlet and outlet ports.



Slide table cylinder

HLF Series



Symbol



Product feature

1. cross roller linear guide and cylinder integrated type design, effectively reducing cylinder thickness.
2. With superior straightness and non-rotating accuracy for precision assembly application.
3. cylinder can be installed from 2 directions.
4. Piping is possible from 2 directions.

Ordering code

HLF 20 × 30 S



① Model	② Bore size	③ Stroke	④ Magnet
HLF: Slide table cylinder (Roller type)	8 12 16 20	Refer to stroke table for details	S: With magnet

Specification

Bore size(mm)	8	12	16	20
Acting type	Double acting			
Fluid	Air(to be filtered by 40µm filter element)			
Operating pressure	0.2~0.7MPa(2.9~10.0bar)	0.15~0.7MPa(2.2~10.0bar)(1.5~7.0bar)		
Proof pressure	1.2MPa(17.5psi)(12.0bar)			
Temperature °C	-20~70			
Speed range mm/s	50~500			
Stroke tolerance	+1.0 0			
Cushion type	Bumper			
Sensor switches [Note1]	DMSH, CMSH, EMSH			
Port size	M3×0.5		M5×0.8	

[Note1] Refer to P362 for detail of sensor switch.

Stroke

Bore size (mm)	Standard stroke (mm)	Max.std stroke
8	10 20 30	30
12	10 20 30 40 50	50
16	10 20 30 40 50 75 100	100
20	10 20 30 40 50 75 100	100

[Note] Consult us for non-standard stroke.

Inner structure and material of major parts

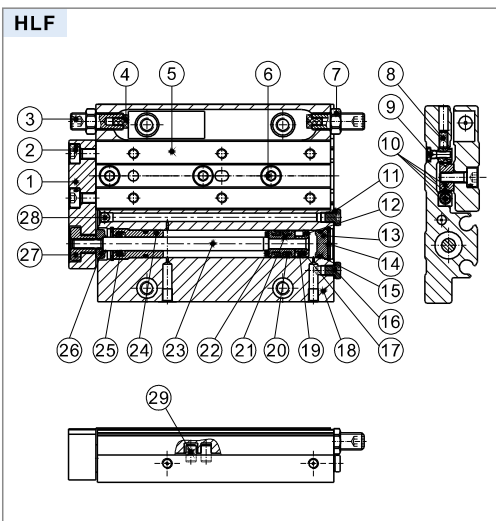

NO.	Item	Material	NO.	Item	Material
1	Fixed plate	Aluminum alloy	16	Plug screw	carbon steel
2	Hexagon socket head screws	Alloy steel	17	Magnet pad	NBR
3	Adjustable screw	Alloy steel	18	Body	Aluminum alloy
4	Bumper	TPU	19	Magnet	Sintered NdFeB
5	Slide table	Aluminum alloy	20	Piston packing	NBR
6	Hexagon socket head screws	Alloy steel	21	Piston	brass
7	Hex nut	Carbon steel	22	Bumper	TPU
8	Socket set screws	Alloy steel	23	Rod	Stainless steel
9	Hexagon socket head screws	Alloy steel	24	Front cover	Aluminum alloy
10	Roller assembly		25	Spool O ring	NBR
11	Gasket	Wear resistant material	26	Floating joint 2	Cutting steel
12	Magnet holder	brass	27	Floating joint 1	Cutting steel
13	Back cover	Aluminum alloy	28	Φ3 steel ball	Stainless steel
14	C clip	Spring steel	29	Pin	Stainless steel
15	O ring	NBR			

Slide table cylinder

HLF Series

Model Selection Method

Please select compact cylinder's type according to following procedure, and cross reference with data sheets.

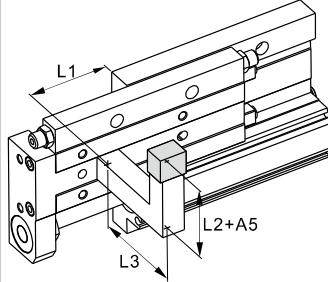
Steps	Calculation formula, data	Example	
1、 Conditions of Use: Consider installation, the shape of the workpiece, the conditions of use.	1. Model used(Bore size, Stroke) 2. Type of cushion(Bumper, Shock absorber) 3. Mounting position of work(Top, front) 4. Mounting direction(Axial, Vertical) 5. Average speed Va(mm/s) 6. Applied load W(kg) Fig. 1 7. Overhang Ln(mm) Fig. 2	 1. Model used: HLF20X50 2. Type of cushion: Bumper 3. Mounting position of work: Table top mounting 4. Mounting direction: Horizontal arm installation 5. Average speed Va=300(mm/s) 6. Applied load W=0.5(kg) 7. Overhang L1=10mm L2=30mm L3=30mm	
2、 Kinetic energy check 1. Calculate kinetic energy of load E(J) 2. Calculate allowable kinetic energy Ea(J) 3. Check that kinetic energy of load doesn't exceed allowable kinetic energy: E≤Ea	$E=W \times (V/1000)^2 / 2$ Impact speed $V=1.4$ (Correction factor (reference value)) $\times V_a$ $E_a=K \times E_{max}$ Mounting work coefficient K: Fig 3 Maximum allowable kinetic energy : Table 1 Kinetic energy of load(E)≤ Allowable kinetic energy(Ea)	$E=0.5 \times (420/1000)^2 / 2=0.044$ $V=1.4 \times 300=420$ $E_a=1 \times 0.16=0.16$ $E=0.044 \leq E_a=0.16$ Can be used	
3、 Load rate check 3-1、 Concentrated load rate 1. Calculate allowable applied load Wa (kg) Note) In the case of vertical use, there is no need to discuss this load rate. ($\alpha_1=0$) 2. Calculate load rate α_1 .	$W_a=K \times \beta \times W_{max}$ Mounting work coefficient K : Fig 3 Applied load coefficient β : Map 1 Maximum allowable applied load W_{max} : Table2 $\alpha_1=W/W_a$	$W_a=1 \times 1 \times 4=4$ $K=1$ $\beta=1$ $W_{max}=4$ $\alpha_1=0.5/4=0.125$	
3-2、 Static moment rate 1. Calculate static moment M(N.m) 2. Calculate allowable static moment Ma(N.m) 3. Calculate static moment rate α_2	$M=W \times 9.8(L_n+A_n)/1000$ Correction value for center position distance of moment An : Table3 $M_a=K \times \gamma \times M_{max}$ Mounting work coefficient K: Fig 3 Allowable moment coefficient γ : Map 2 Maximum allowable moment M_{max} : Table4 $\alpha_2=M/M_a$	Yaw moment My $M_y=0.5 \times 9.8(10+11)/1000=0.11$ $A_3=11$ $M_{y_{max}}=1 \times 1 \times 9.14=9.14$ $M_{y_{max}}=9.14$ $K=1$ $\gamma=1$ $\alpha_2=0.11/9.14=0.012$	Roll moment Mr $M_r=0.5 \times 9.8(30+17)/1000=0.23$ $A_6=17$ $M_{r_{max}}=9.14$ (Same as $M_{y_{max}}$) $\alpha_2=0.23/9.14=0.025$
3-3、 Dynamic moment rate 1. Calculate dynamic moment Me(N.m) 2. Calculate allowable dynamic moment Mea(N.m) 3. Calculate dynamic moment rate α_3 .	$M_e=(W_e \times 9.8(L_n+A_n)/1000)/3$ Impact equivalent mass $W_e=\delta \times W \times V$ δ : Cushion factor With polyurethane bumper (standard)=4/100 Correction value for center position distance of moment An : Table3 $M_{e_a}=K \times \gamma \times M_{max}$ Mounting work coefficient K: Fig 3 Allowable moment coefficient γ : Map 2 Maximum allowable moment M_{max} : Table4 $\alpha_3=M_e/M_{e_a}$	Pitch moment Mep $M_{ep}=(8.4 \times 9.8(30+17)/1000)/3=1.3$ $W_e=4/100 \times 0.5 \times 420=8.4$ $A_2=17$ $M_{ep_{max}}=1 \times 0.7 \times 9.14=6.40$ $K=1$ $\gamma=0.7$ $M_{p_{max}}=9.14$ $\alpha_3=1.3/6.40=0.20$	Yaw moment Mey $M_{ey}=(8.4 \times 9.8(30+34)/1000)/3=1.8$ $W_e=8.4$ $A_4=34$ $M_{ey_{max}}=6.4$ (Same as $M_{ep_{max}}$) $\alpha_3=1.8/6.4=0.28$
3-4、 Sum of load ratio The total load rate does not exceed 1, can be used.	$\Sigma \alpha_n=\alpha_1+\alpha_2+\alpha_3 \leq 1$	Depent on: $\Sigma \alpha_n=\alpha_1+\alpha_2+\alpha_3$ $=0.125+0.012+0.025+0.20+0.28=0.642 \leq 1$ Can be used.	

Slide table cylinder

HLF Series

Fig. 1 Applied load : W(kg)

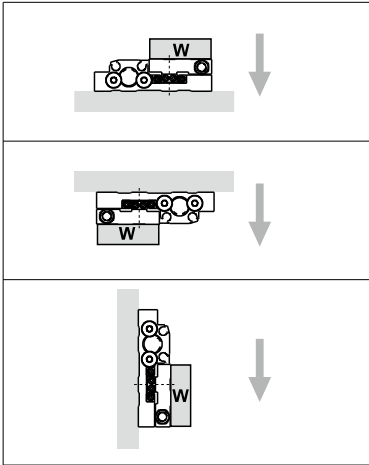

Note: The state of vertical use does not need to consider this load rate.

Fig 3 Mounting work coefficient: K

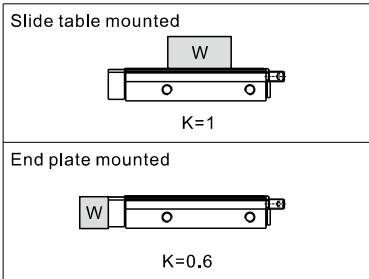

Table2 Maximum allowable applied load : Wmax(kg)

Model	Wmax
HLF8	0,6
HLF12	1
HLF16	2
HLF20	4

Table4 Maximum allowable moment : Mmax(N.m)

Type	Stroke (mm)					
	10	20	30	50	70	100
HLF8	0.56	0.78	0.98	-	-	-
HLF12	-	1.65	2.22	3.34	-	-
HLF16	-	-	3.41	5.69	7.96	-
HLF20	-	-	6.66	9.14	13.70	18.27

Symbol and Unit

Symbol	Item	Unit	Symbol	Item	Unit
An(n=1~6)	Correction value for center position distance of moment	mm	Va	Average speed	mm/s
E	Kinetic energy	J	W	Applied load	kg
Ea	Allowable kinetic energy	J	Wa	Allowable applied load	kg
Emax	Maximum allowable kinetic energy	J	We	Impact equivalent load	kg
Ln(n=1~3)	Overhang	mm	Wmax	Maximum allowable applied load	kg
M(Mp , My , Mr)	Static moment(Pitch, Yaw, Roll)	N.m	α	Load rate	-
Ma(Map , May , Mar)	Allowable static moment(Pitch, Yaw, Roll)	N.m	β	Applied load coefficient	-
Me(Mep , Mey)	Dynamic moment(Pitch, Yaw)	N.m	γ	Allowable moment coefficient	-
Mea(Meap , Meay)	Allowable dynamic moment(Pitch, Yaw)	N.m	δ	Bumper	-
Mmax(Mpmax , Mymax , Mrmax)	Maximum allowable static moment(Pitch, Yaw, Roll)	N.m	K	Mounting work coefficient	-
V	Impact speed	mm/s			

Fig. 2 Overhang : Ln(mm). Correction value for center position distance of moment: An(mm)

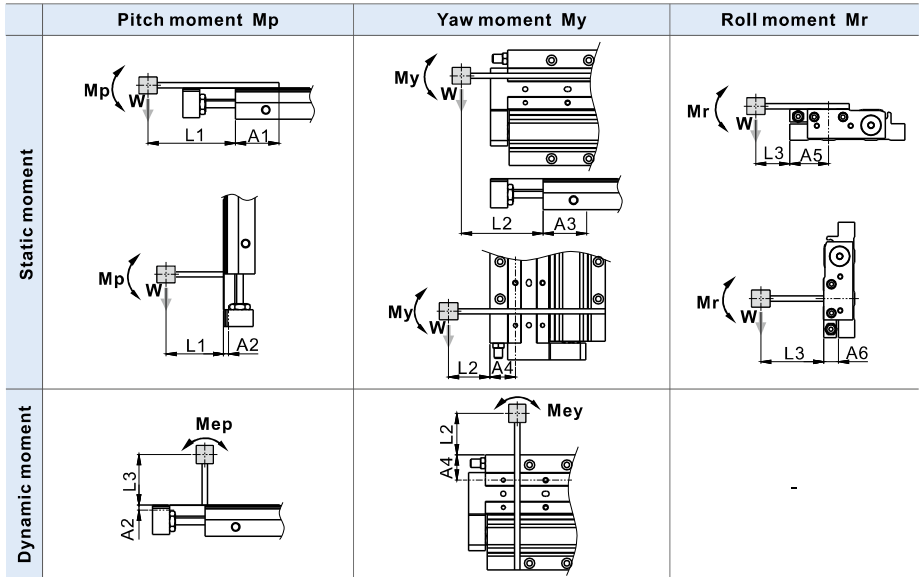

Note: Static moment: Generated by gravity.
Dynamic moment: Generated by the impact when the limiter is impacted.

Table 1 Maximum allowable kinetic energy :Emax(J)

Type	Emax(Bumper)
HLF8	0.027
HLF12	0.055
HLF16	0.11
HLF20	0.16

Table3 Correction value for center position distance of moment: An(mm)

Model	An					
	A ₁	A ₂	A ₃	A ₄	A ₅	A ₆
HLF8	6 Note1	10	6 Note1	21	21	10
HLF12	10	11	10	23	23	11
HLF16	10	12	10	28	28	12
HLF20	11	17	11	34	34	17

Note1 : Only HLF8X10 is 16mm.

Map 1 Applied load coefficient : β

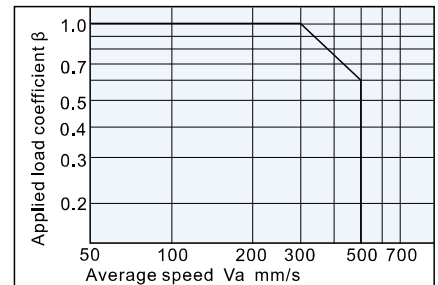

Map 2 Allowable moment coefficient: γ

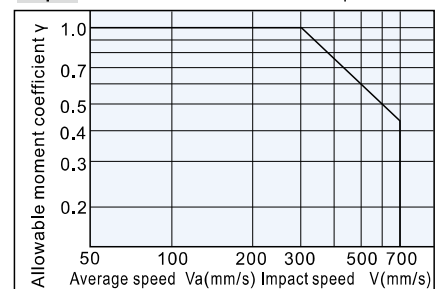

Note: Calculate static moment using average speed
Calculate dynamic moment using impact speed

Slide table cylinder

HLF Series

HLF16

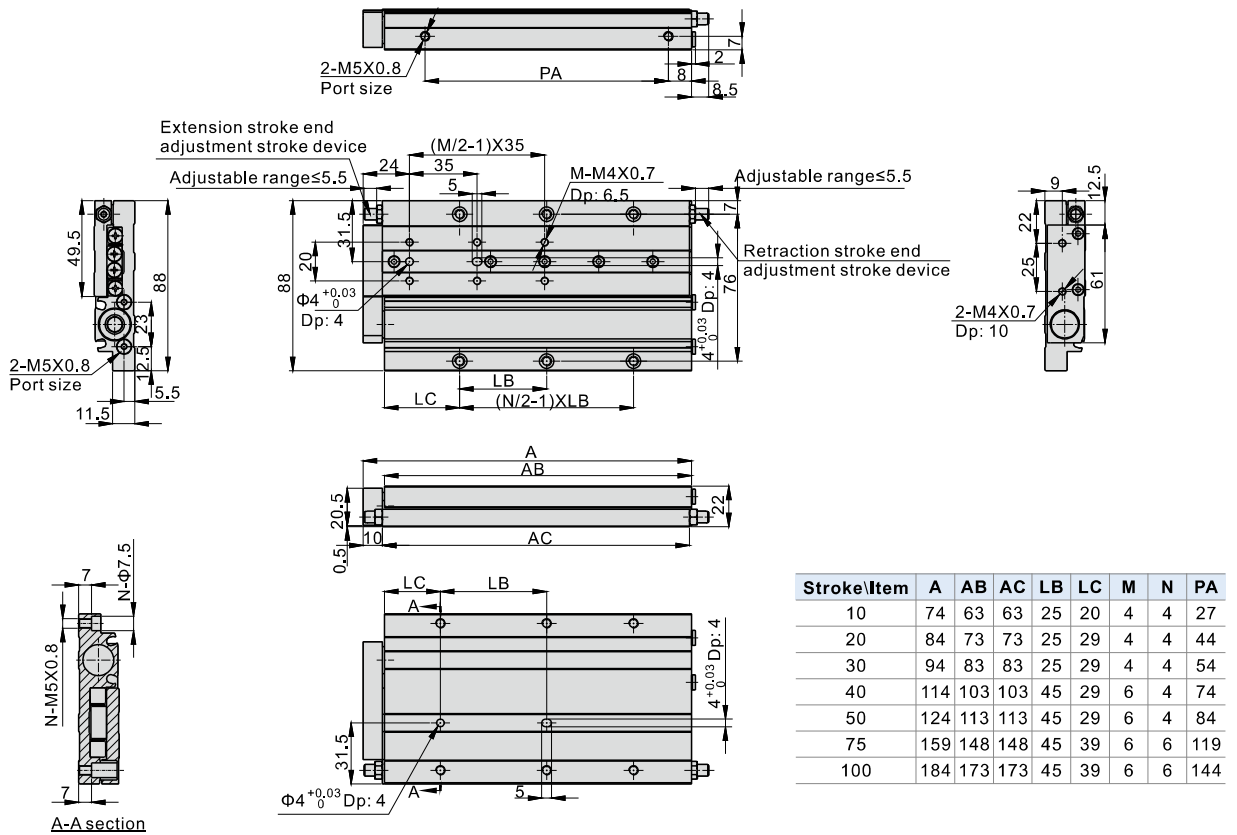

HLF20

