



Power clamp cylinder—J SCK Series

Compendium of J SCK Series

4 Arm styles are available

4 Arm styles AM1, AM2, AM3 and AM4 each with 3 specifications R, C and L for uses in different situations.

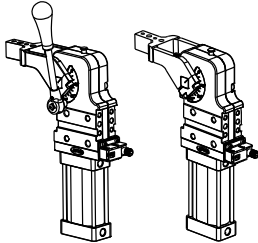

Manual type Standard type

Standard and Manual type are available

4 sides are to be mounted

With dimensions subject to DIN standard.

Designed as a whole

Mechanism and cylinder designed as a whole.

Rod-crank-slider structure

Rod-crank-slider structure made of high-strength, highly-wear-resisting material is adopted.

- a) Stable and reliable structure which can produce large clamping force at low working pressure.
- b) Self-lock mechanism is adopted at clamping position which can still provide clamping force even after compressed air is off.

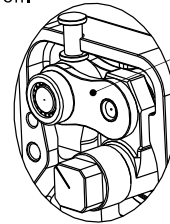

Rod-crank-slider structure

Electrical or Air inductive approaching sensor

No sensor

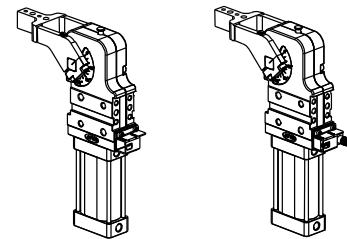

Electrical Inductive approaching sensor (PNP/NPN type to be chosen)

Fixed opening angle

9 opening angles are optional by changing the barrel length; The smaller the opening angle, the shorter the barrel.

Oval-shaped cylinder which is space efficient

Application



Power clamp cylinder

JSCK Series—Standard type



Specification



Model	JSCK40	JSCK50	JSCK63	JSCK80
Output torque (0.5MPa)	120N.m	160N.m	380N.m	800N.m
Acting type	Double acting			
Fluid	Air(to be filtered by 40μm filter element)			
Operating pressure	0.3~0.8MPa(43~116psi)			
Proof pressure	1.2MPa(175psi)			
Temperature	-20~70 °C			
Opening angle	15°/30°/45°/60°/75°/90°/105°/120°/135°			
Minimum opening and closure time	1 second clamping, 1 second opening			
Position sensing	Electrical approaching sensor			
Cushion type	Air buffer			
Weight (135°) [Note1]	2.0kg	3.7kg	5.0kg	12.0kg
Port size [Note2]	1/8"		1/4"	





[Note1] This weight includes 15mm offset clamping arm;

[Note2] PT thread, G thread are available.

Ordering code

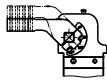
JSCK □ 50 ×135 AM1R K □ □

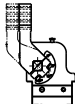
① ② ③ ④ ⑤ ⑥ ⑦ ⑧

① Model	② Clamping arm position	③ Bore size	④ Opening angle	⑤ Clamping arm [Note2]	⑥ Sensor switch [Note3]	⑦ Thread type	⑧ Port				
JSCK: Power clamp cylinder (Double acting)	Blank: horizontal	40(circular)	15 30 45 60 75 90 105 120 135 [Note1]	Blank: No clamping arm	Blank: No sensor switch	Blank: PT G: G	Blank				
				AM1: Offset 15mm			R C L	B			
							AM3: Offset 45mm	R C L	Port		
							AM2: Offset 15mm	R C L			
	V: Vertical			50(oval) 63(oval) 80(oval)			15 30 45 60 75 90 105 120 135 [Note1]	Blank: No clamping arm	K: With electrical sensor switch (PNP) KN: With electrical sensor switch (NPN)	Blank	B
											
			AM3: Offset 45mm		R C L						
			AM4: Offset 45mm		R C L						

[Note1] Please refer to the right table for details of max. opening angle.

[Note2] Please refer to the drawing for detailed dimensions of clamping arm. Clamping arm AM1 and AM2 for 80 offset 20mm.

[Note3] K/KN type sensor switch can be ordered separately and please refer to relative contents.

Bore size	Arm position	Arm type	Maximum opening angle	Bore size	Arm position	Arm type	Maximum opening angle
40	horizontal	AM1	135°	50 63 80	horizontal	AM1, AM3	135°
		AM3	105°			AM2, AM4	
	Vertical(V)	AM1	120°		Vertical(V)	AM1, AM3	105°
		AM3	105°			AM2, AM4	

Weight Comparison with JCK series

Opening angle	40			50			63			80		
	JSCK	JCK	Weight reduction	JSCK	JCK	Weight reduction	JSCK	JCK	Weight reduction	JSCK	JCK	Weight reduction
15°	1.46	1.71	14.6%	2.61	3.36	22.3%	3.64	4.84	24.8%	8.87	11.30	21.5%
30°	1.47	1.70	13.5%	2.63	3.34	21.3%	3.68	4.80	23.3%	8.99	11.22	19.9%
45°	1.48	1.70	12.9%	2.65	3.32	20.2%	3.72	4.77	22.0%	9.08	11.16	18.6%
60°	1.49	1.70	12.4%	2.67	3.30	19.1%	3.76	4.74	20.7%	9.18	11.11	17.4%
75°	1.50	1.69	11.2%	2.70	3.27	17.4%	3.80	4.71	19.3%	9.27	11.09	16.4%
90°	1.51	1.69	10.7%	2.71	3.25	16.6%	3.83	4.68	18.2%	9.36	10.99	14.8%
105°	1.52	1.68	9.5%	2.74	3.23	15.2%	3.87	4.65	16.8%	9.46	10.93	13.4%
120°	1.53	1.68	8.9%	2.75	3.21	14.3%	3.90	4.62	15.6%	9.53	10.88	12.4%
135°	1.54	1.67	7.8%	2.77	3.20	13.4%	3.93	4.57	14.0%	9.59	10.84	11.5%

[Note] The above weight does not include the weight of the clamping arm. (Unit: kg)



Power clamp cylinder

JSCK Series—Standard type

Inner structure and material of major parts

NO.	Item	Material	NO.	Item	Material
1	Back cover	Aluminum alloy	11	Bushing	Alloy steel
2	Aluminum barrel	Aluminum alloy	12	Retaining pin	Carbon steel
3	Cushion body	Aluminum alloy	13	Connecting rod	Carbon steel
4	Piston	Aluminum alloy+NBR	14	Clamping arm	Carbon steel
5	Front cover	Aluminum alloy	15	Pivot	Alloy steel
6	Sensor switch		16	Bushing	Alloy steel
7	Sensor switch fix	Plastic	17	End cap	Aluminum alloy
8	Inductive block	Carbon steel	18	Spool O-ring	TPU
9	I Knuckle	Alloy steel	19	Cushing O-ring	TPU
10	Strengthen steel plate	Alloy steel	20	O-ring	NBR

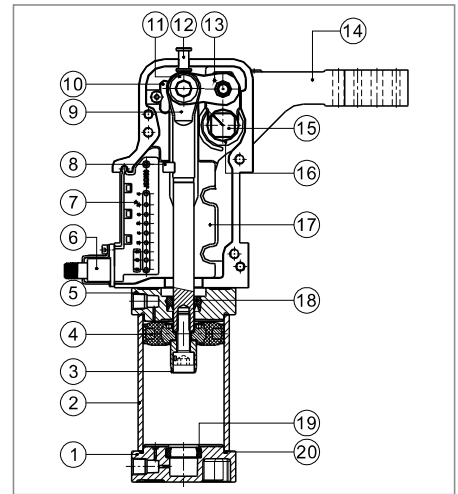

How to select product

1. Please design appropriate fixture according to "Allowable Arm Load-Load Offset curve" diagram.

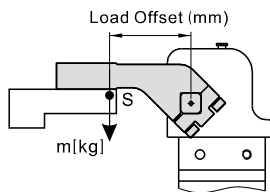

Bore size	Maximum load torque	
	1 second period	2 second period
40	2,2Nm	3,3Nm
50	4,5Nm	6,7Nm
63	6,0Nm	9,0Nm
80	8,0Nm	11,2Nm

S: distance from pivot point to center of mass of clamping arm
m: weight of clamping arm

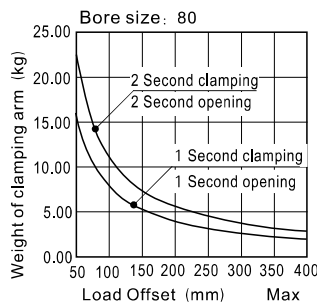
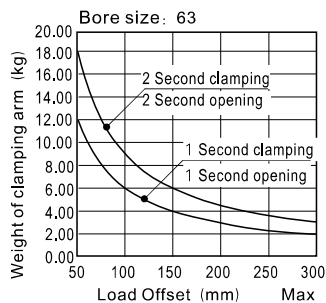
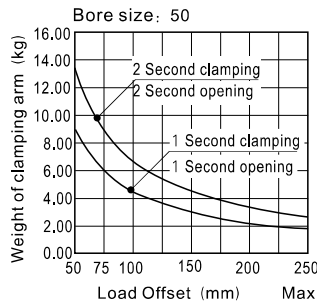
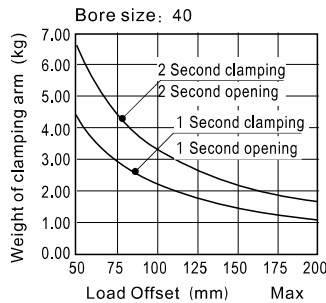

Attention: Please use with speed control valve.

2. Please choose appropriate clamping position according to "Torque-Clamping Arm Length curve" diagram.

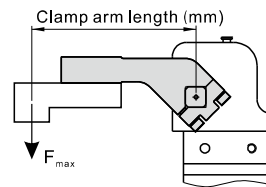

Note: For clamping force is produced by elbow mechanism, maximum torque is only reached at final clamping arm position.

Bore size	Maximum holder torque
40	380Nm
50	800Nm
63	1500Nm
80	2500Nm

Bore size	Maximum clamp torque					
	0.3MPa	0.4MPa	0.5MPa	0.6MPa	0.7MPa	0.8MPa
40	72Nm	95Nm	120Nm	143Nm	167Nm	191Nm
50	99Nm	132Nm	165Nm	198Nm	230Nm	264Nm
63	230Nm	307Nm	384Nm	460Nm	537Nm	614Nm
80	482Nm	643Nm	803Nm	964Nm	1124Nm	1285Nm

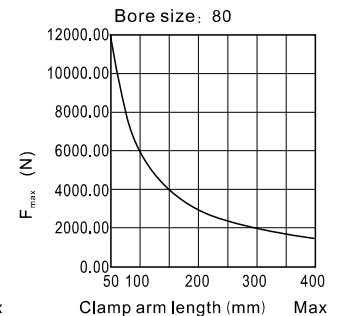
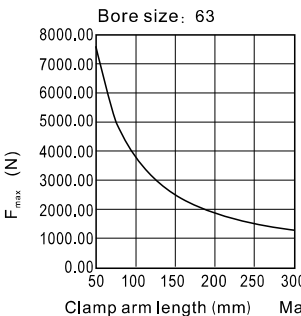
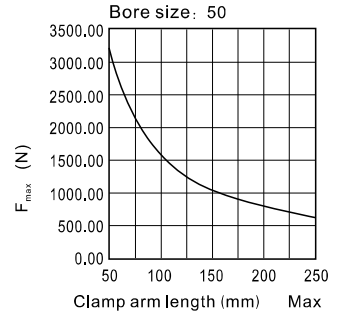
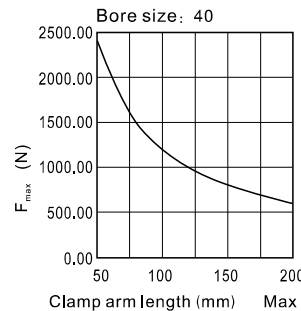

Power clamp cylinder

JSKC Series—Standard type

3. Please choose appropriate washer according to "Torque-Spacer thickness curve" diagram.

Note: Inserted washer exceeding maximum clamping torque position may lead to self-lock failure. Take safety issue into account when considering thickness of spacer inserted.

Besides, clamping arm length L represents distance from pivot point to clamping position. For distance from mounting base locating hole to pivot A, please refer to the following table.

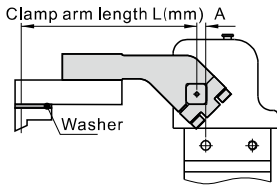

Bore size	A(mm)
40	12
50	10
63	10
80	15

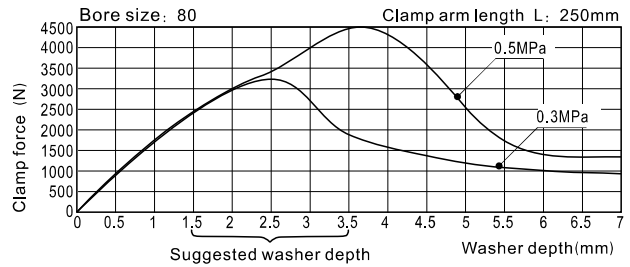
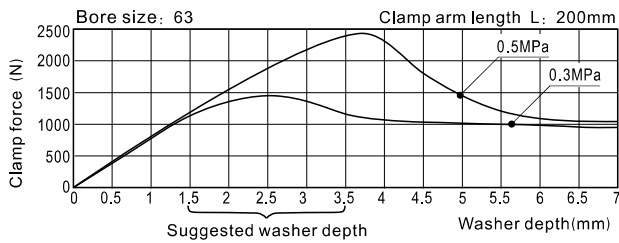
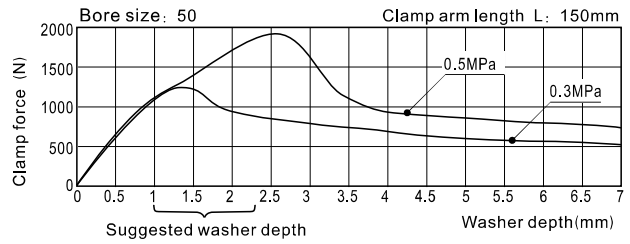
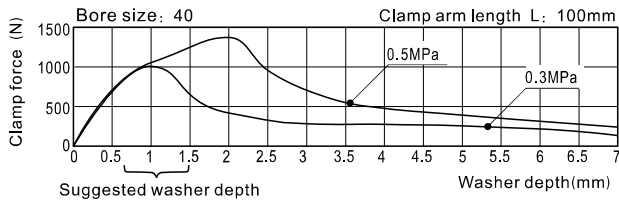

Dimensions

JSK40AM1

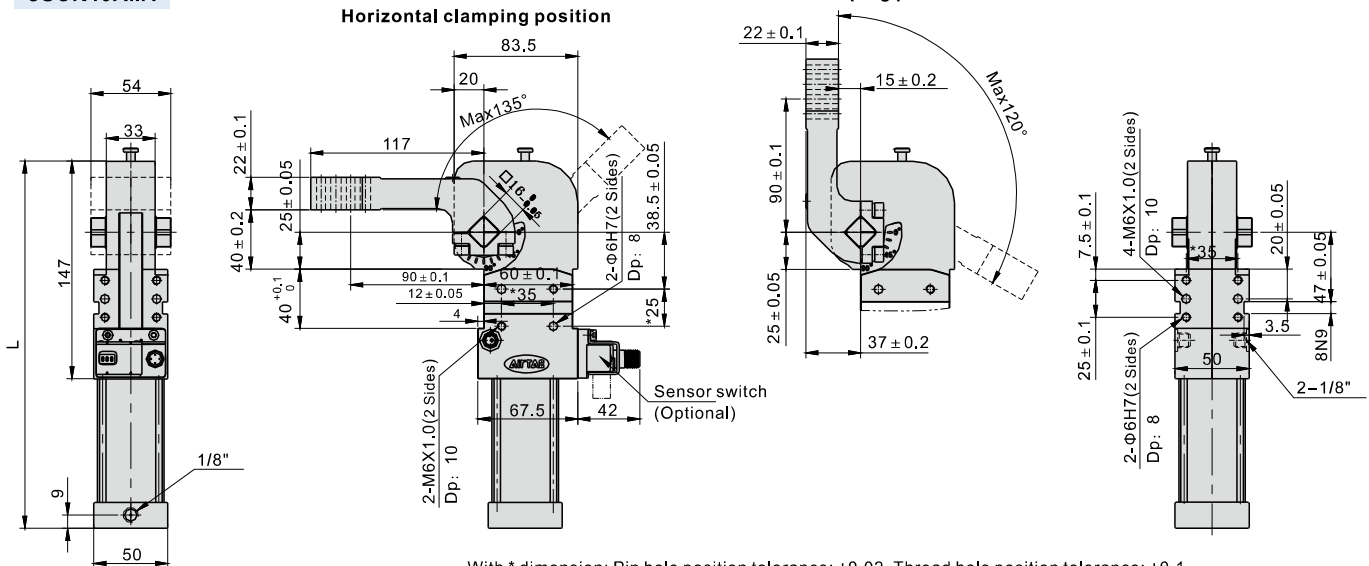

With * dimension: Pin hole position tolerance: ± 0.02 . Thread hole position tolerance: ± 0.1 .

Maximum opening angle	Total length of cylinder(L)	Maximum opening angle	Total length of cylinder(L)
15°	196.5	90°	231
30°	204.5	105°	238
45°	211	120°	244
60°	218	135°	248
75°	224.5		

Power clamp cylinder



JSCK Series—Standard type

JSCK40AM3

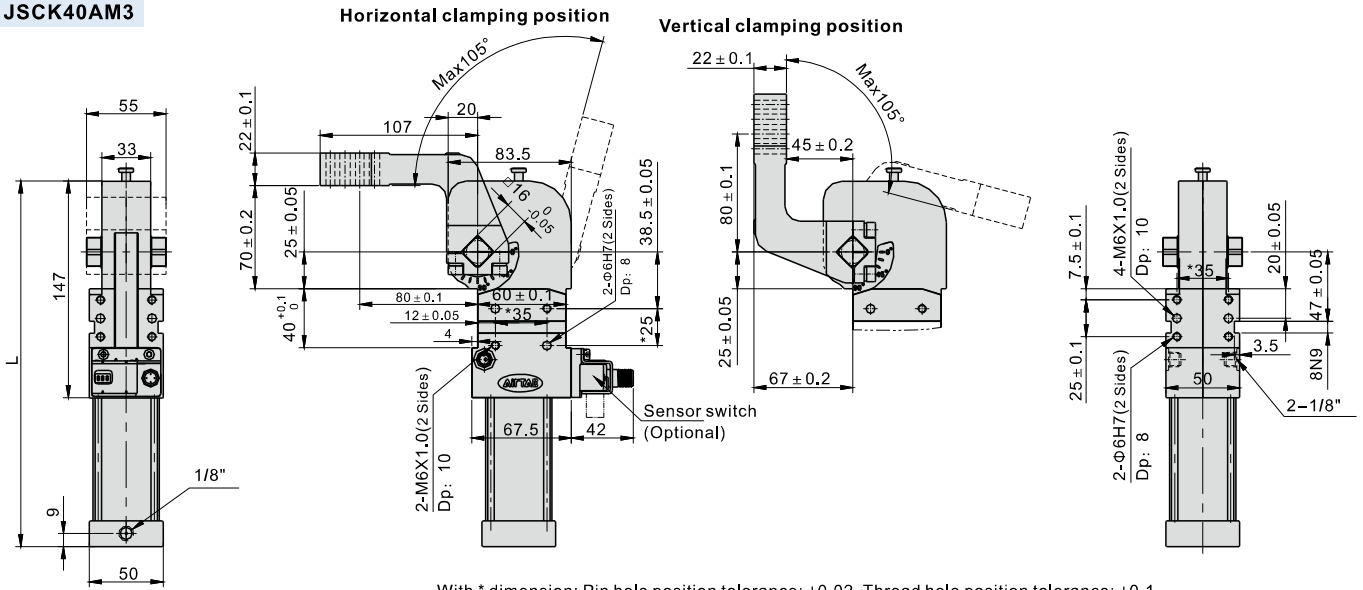

With * dimension: Pin hole position tolerance: ± 0.02 . Thread hole position tolerance: ± 0.1 .

Maximum opening angle	Total length of cylinder(L)	Maximum opening angle	Total length of cylinder(L)
15°	196.5	90°	231
30°	204.5	105°	238
45°	211	120°	244
60°	218	135°	248
75°	224.5		

JSCK50AM1(2)

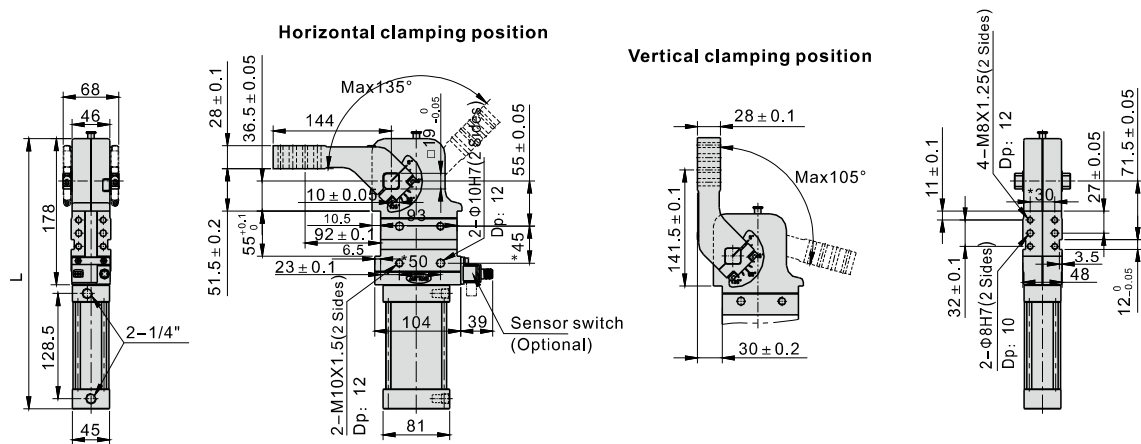

With * dimension: Pin hole position tolerance: ± 0.02 . Thread hole position tolerance: ± 0.1 .

Maximum opening angle	Total length of cylinder(L)	Maximum opening angle	Total length of cylinder(L)
15°	273.5	90°	311
30°	282	105°	318
45°	289	120°	324.5
60°	296.5	135°	329
75°	303.5		



Power clamp cylinder

JSCK Series—Standard type

JSCK50AM3(4)

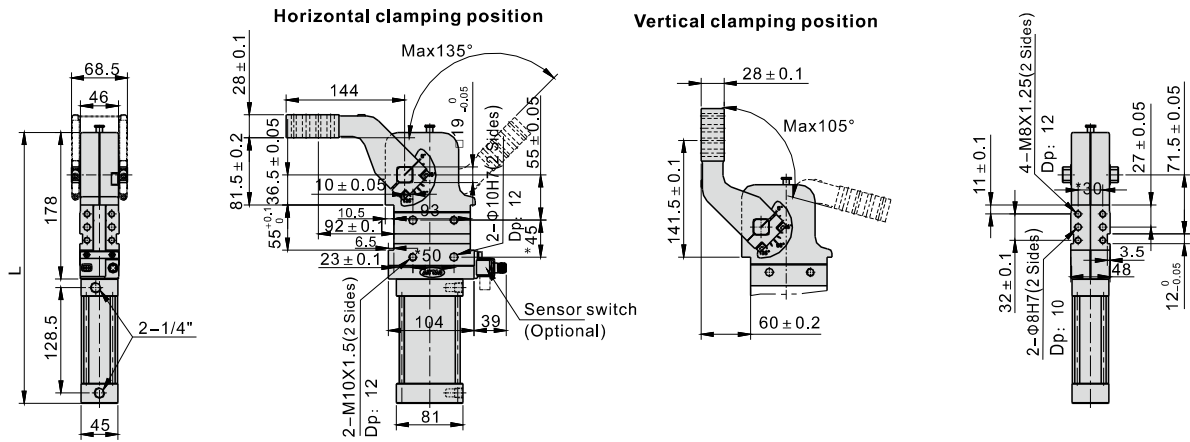

With * dimension: Pin hole position tolerance: ± 0.02 . Thread hole position tolerance: ± 0.1 .

Maximum opening angle	Total length of cylinder(L)	Maximum opening angle	Total length of cylinder(L)
15°	273.5	90°	311
30°	282	105°	318
45°	289	120°	324.5
60°	296.5	135°	329
75°	303.5		

JSCK63AM1(2)

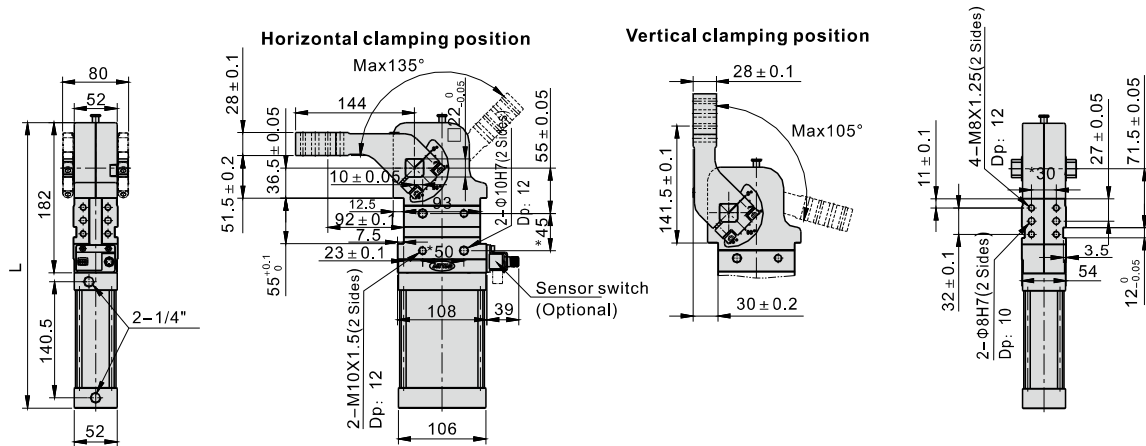

With * dimension: Pin hole position tolerance: ± 0.02 . Thread hole position tolerance: ± 0.1 .

Maximum opening angle	Total length of cylinder(L)	Maximum opening angle	Total length of cylinder(L)
15°	283	90°	325
30°	293	105°	333
45°	301	120°	340
60°	309	135°	345.5
75°	317		

Power clamp cylinder

JSKC Series—Standard type



JSC63AM3(4)

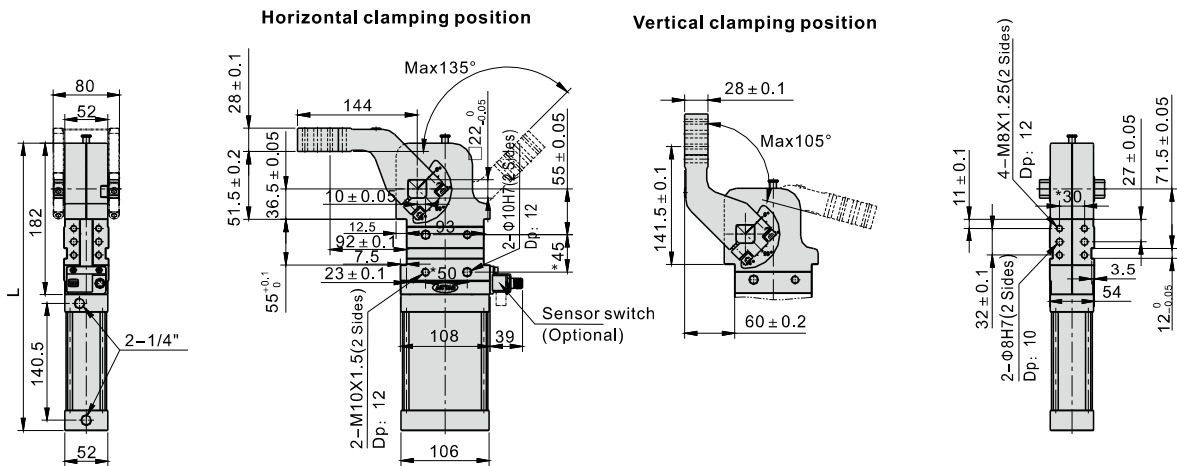

With * dimension: Pin hole position tolerance: ±0.02, Thread hole position tolerance: ±0.1.

Maximum opening angle	Total length of cylinder(L)	Maximum opening angle	Total length of cylinder(L)
15°	283	90°	325
30°	293	105°	333
45°	301	120°	340
60°	309	135°	345.5
75°	317		

JSC80AM1(2)

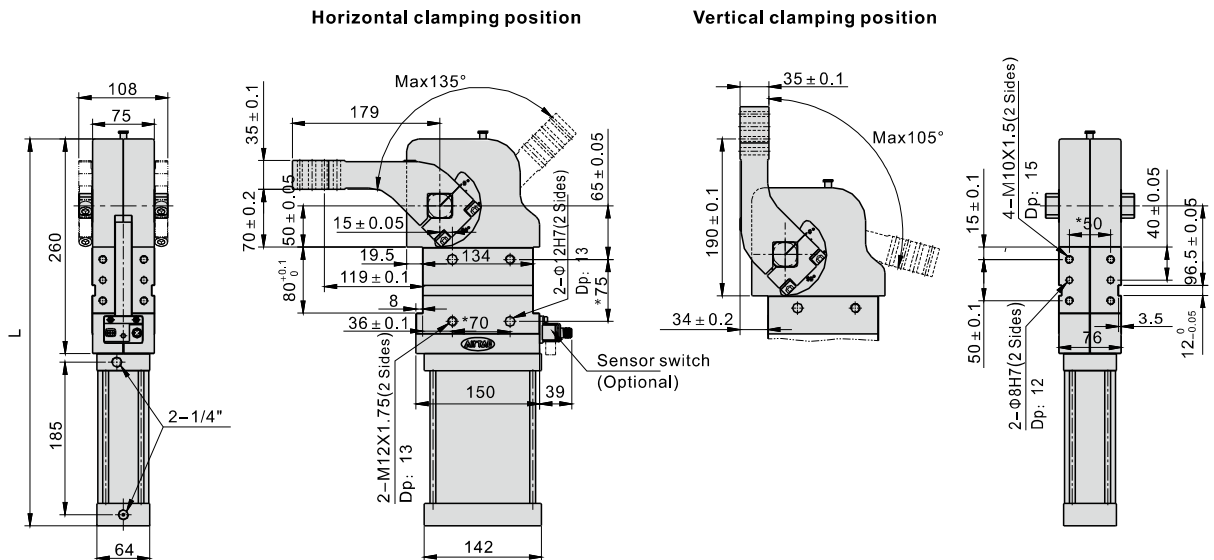

With * dimension: Pin hole position tolerance: ±0.02, Thread hole position tolerance: ±0.1.

Maximum opening angle	Total length of cylinder(L)	Maximum opening angle	Total length of cylinder(L)
15°	378.5	90°	440.5
30°	393	105°	452
45°	405	120°	462
60°	417	135°	469
75°	429		



Power clamp cylinder

JSKC Series—Standard type

JSKC80AM3(4)

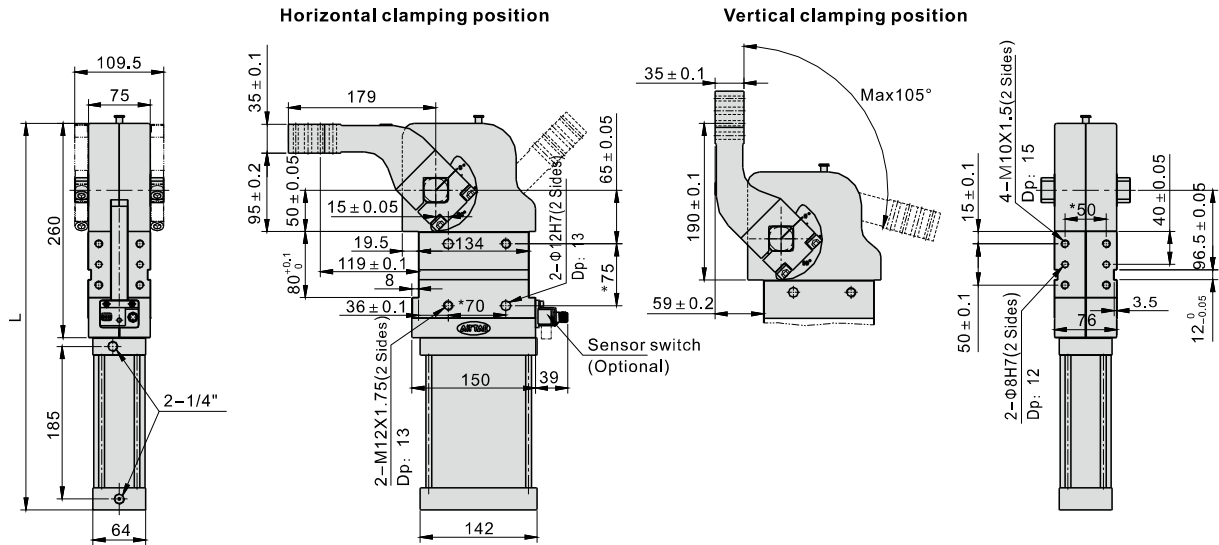

With * dimension: Pin hole position tolerance: ± 0.02 , Thread hole position tolerance: ± 0.1 .

Maximum opening angle	Total length of cylinder(L)	Maximum opening angle	Total length of cylinder(L)
15°	378.5	90°	440.5
30°	393	105°	452
45°	405	120°	462
60°	417	135°	469
75°	429		

Power clamp cylinder

JSCK Series—Manual type



Specification

Model	JSCK40	JSCK50	JSCK6380
Output torque (0.5MPa)	120N.m	160N.m	380N.m
Acting type	Double acting		
Fluid	Air(to be filtered by 40μm filter element)		
Operating pressure	0.3~0.8MPa(43~116psi)		
Proof pressure	1.2MPa(175psi)		
Temperature	-20~70 °C		
Opening angle	15°/30°/45°/60°/75°/90°/105°/120°		
Minimum opening and closure time	1 second clamping, 1 second opening		
Position sensing	Electrical approaching sensor		
Cushion type	Air buffer		
Weight (135°) [Note1]	2.4kg	4.2kg	5.5kg
Port size [Note2]	1/8"		1/4"

[Note1] This weight includes 15mm offset clamping arm;

[Note2] PT thread, G thread are available.

Ordering code

JSCK □ 50X120 AM1R HL K □ □

① ② ③ ④ ⑤ ⑥ ⑦ ⑧ ⑨

① Model	② Clamping arm position	③ Bore size	④ Opening angle	⑤ Clamping arm [Note2]	⑥ Handle location	⑦ Sensor switch	⑧ Thread type	⑨ Port
JSCK: Power clamp cylinder (Double acting)	Blank: horizontal 	40 (circular)	15 30 45 60 75 90 105 120 [Note1]	Blank: No clamping arm	Blank: non-manual HL: handle on the left 	Blank: No sensor switch	Blank: PT	Blank B
	AM1: Offset 15mm 			R C L 				Blank B
	V: Vertical 	50(oval) 63(oval)		Blank: No clamping arm	HR: handle on the right 	K: With electrical sensor switch (PNP) KN: With electrical sensor switch (NPN) [Note3]	Blank: G	Blank B
	AM3: Offset 45mm 			R C L 				Blank B
				AM2: Offset 15mm 				
				AM4: Offset 45mm 				

[Note1] Please refer to the right table for details of max. opening angle.

[Note2] K/KN type sensor switch can be ordered separately and please refer to relative contents.

Bore size	Arm position	Arm type	Maximum opening angle	Bore size	Arm position	Arm type	Maximum opening angle
40	horizontal	AM1	105°	50	horizontal	AM1, AM3	120°
	Vertical(V)	AM3			Vertical(V)	AM2, AM4	
				63	Vertical(V)		105°

Examples for using

- When the clamped plate is hollow and thin, the final clamping position should be reached manually at low speed before clamping with force to avoid scallops left by fast clamping.
- When clamping forearm has a locating pin, it should be pushed out of the locating hole manually. (Clamping should be done before the pin is well located.)
- When clamping mechanism is complicated with many small sheet-metal parts, clamping should be done manually at first to avoid compressed air flushing well-assembled sheet-metal parts.

Note: Part of manually clamping applications are listed above. Other welding process may be in need of manually clamping.

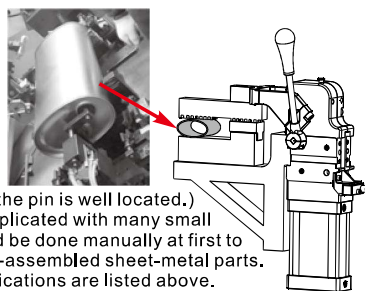

Contrast of self-lock and unlock

Standard type

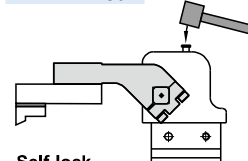

Self-lock:
1. By inletting compressed air.

Unlock:
1. By inletting compressed air.
2. By knocking retaining pin.

Manual type

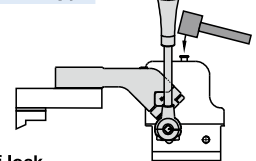

Self-lock:
1. By inletting compressed air.
2. By handle.

Unlock:
1. By inletting compressed air.
2. By knocking retaining pin.
3. By handle.



Power clamp cylinder

JSCK Series—Manual type

Dimensions

JSCK40AM1HL(HR)

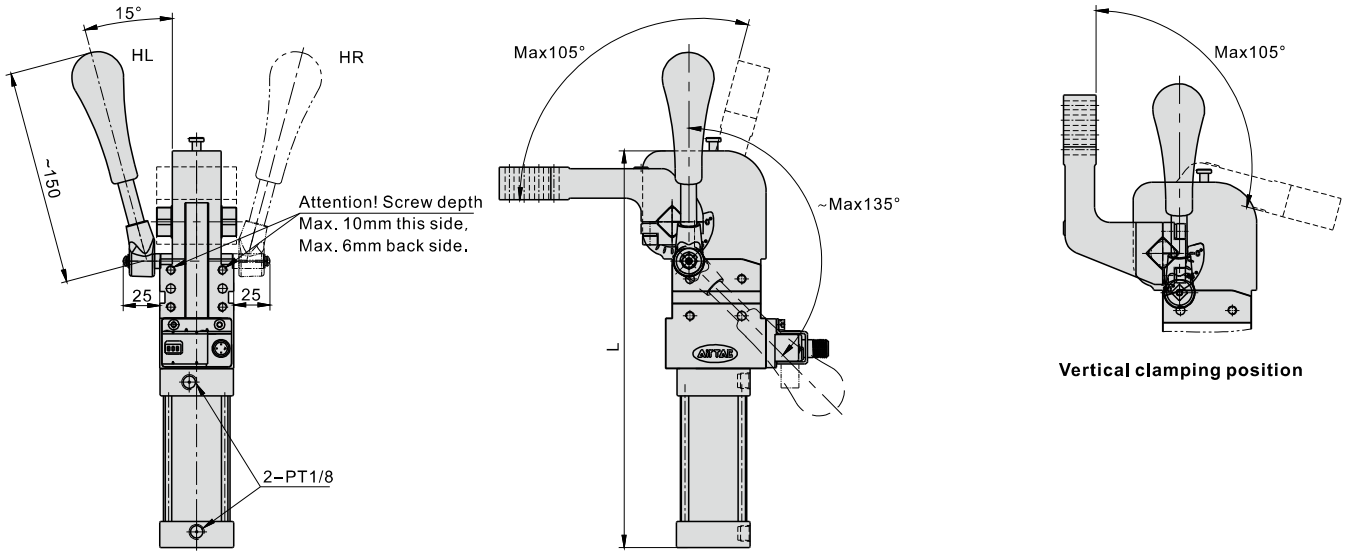

Note: Please refer to standard type for the others dimensions.

JSCK40AM3HL(HR)

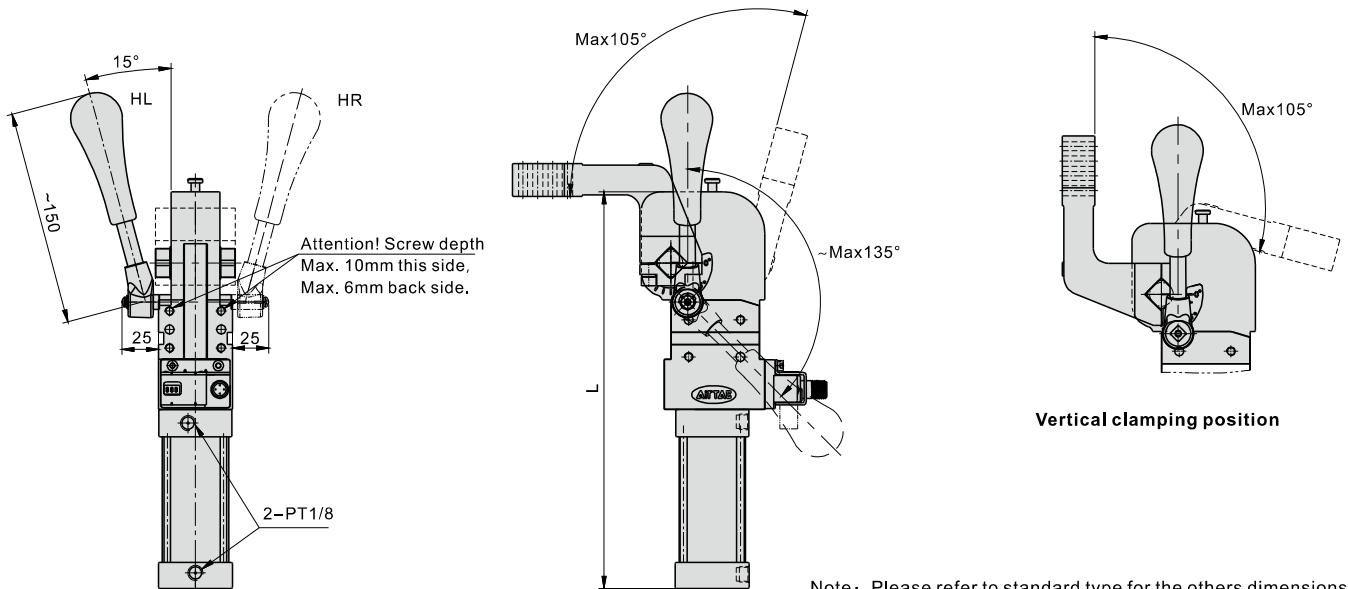

Note: Please refer to standard type for the others dimensions.

Maximum opening angle	Total length of cylinder(L)	Maximum opening angle	Total length of cylinder(L)
15°	226.5	75°	254.5
30°	234.5	90°	261
45°	241	105°	268
60°	248		

Power clamp cylinder

JSKC Series—Manual type

JSKC50AM1(2)HL(HR)

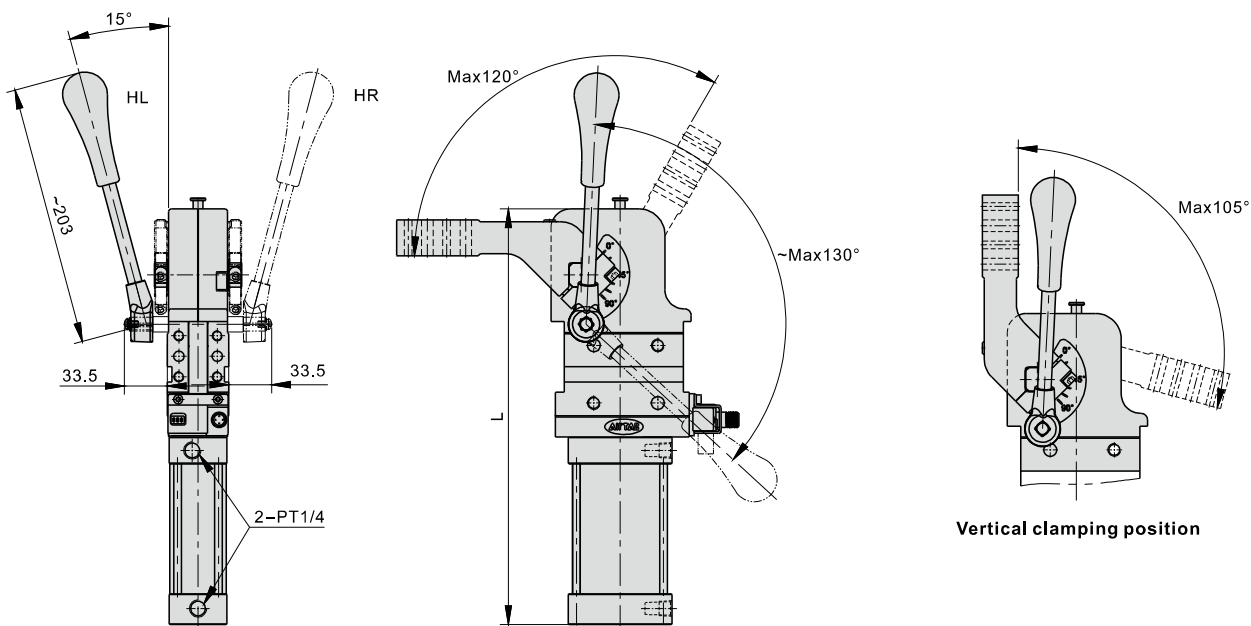

Note: Please refer to standard type for the others dimensions.

JSKC50AM3(4)HL(HR)

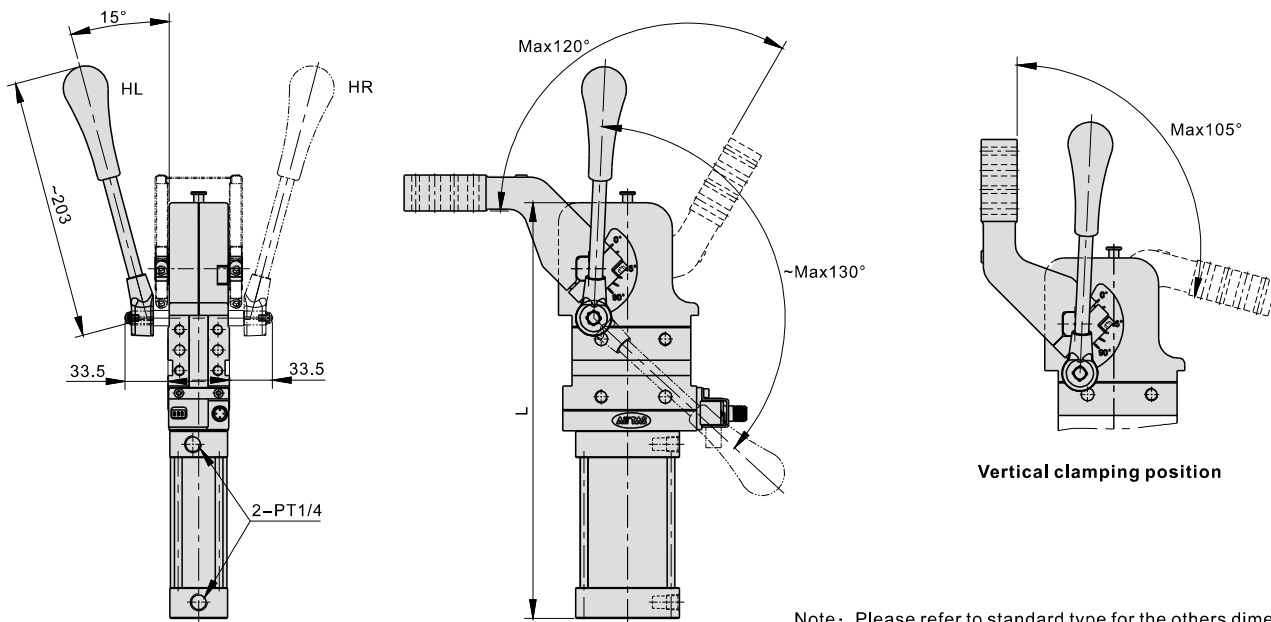

Note: Please refer to standard type for the others dimensions.

Maximum opening angle	Total length of cylinder(L)	Maximum opening angle	Total length of cylinder(L)
15°	273.5	75°	303.5
30°	282	90°	311
45°	289	105°	318
60°	296.5	120°	324.5

Power clamp cylinder

JSKC Series—Manual type

JSC63AM1(2)HL(HR)

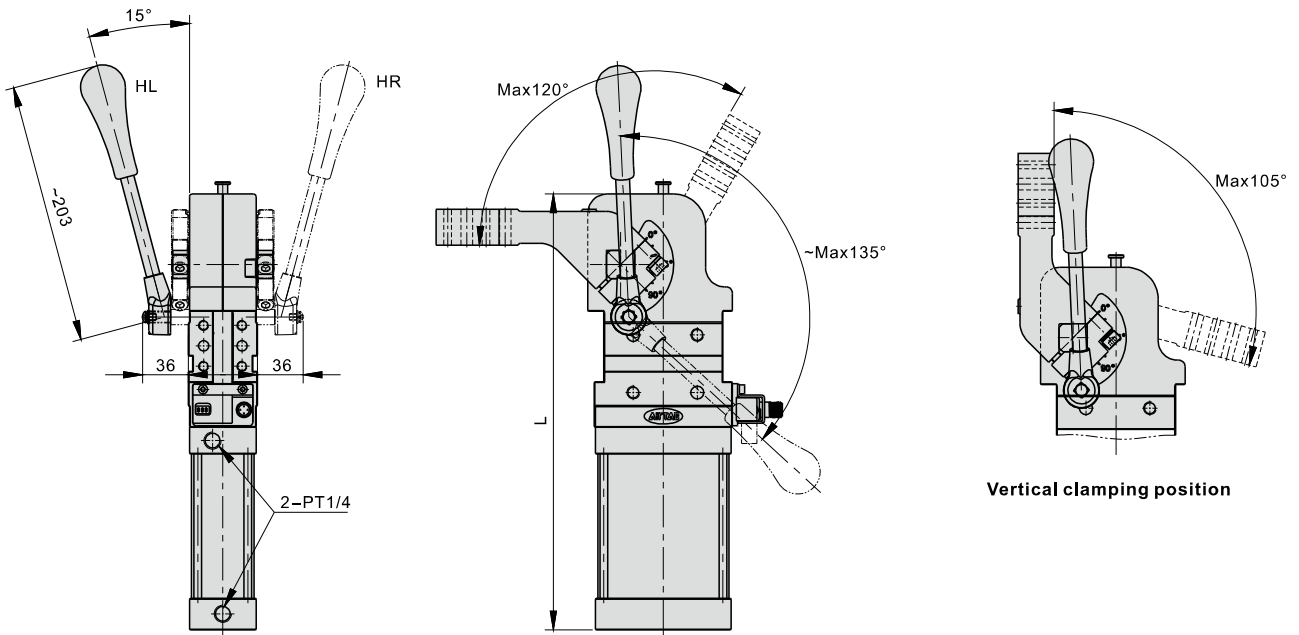

Note: Please refer to standard type for the others dimensions.

JSC63AM3(4)HL(HR)

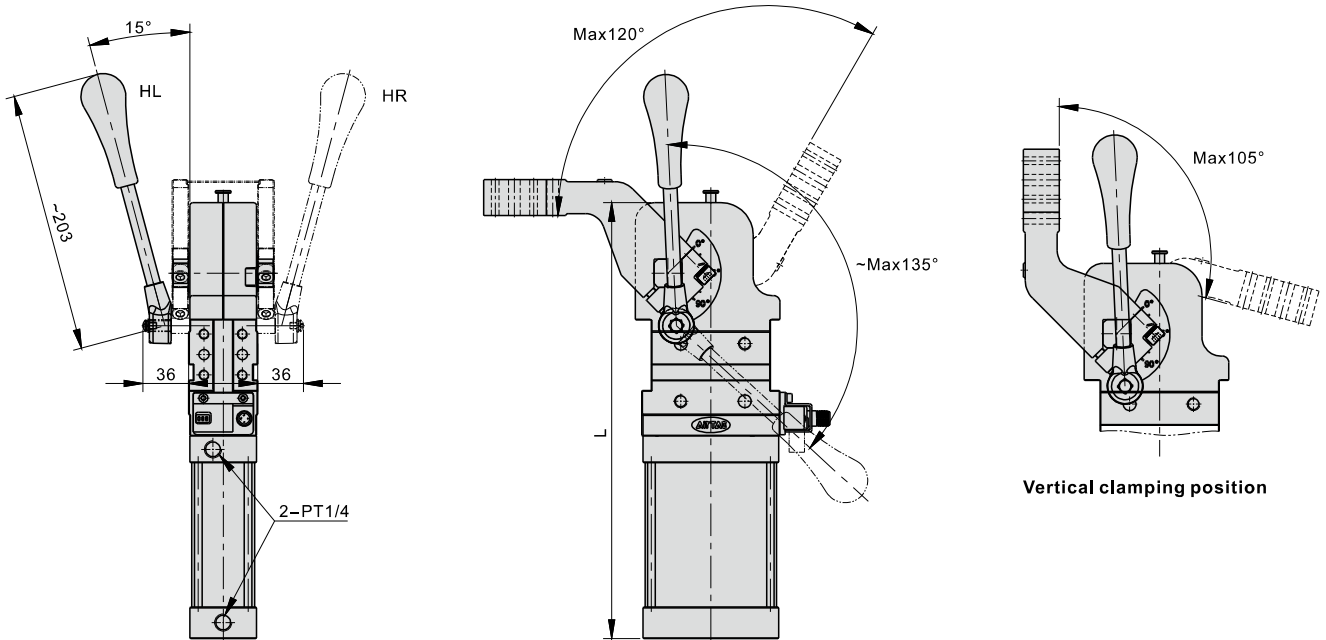

Note: Please refer to standard type for the others dimensions.

Maximum opening angle	Total length of cylinder(L)	Maximum opening angle	Total length of cylinder(L)
15°	283	75°	317
30°	293	90°	325
45°	301	105°	333
60°	309	120°	340

Power clamp cylinder

JSCK Series—Clamp arm



How to select clamp arm

Accessories/Cylinder type		JSCK40	JSCK50	JSCK63	JSCK80
Clamp arm	F-JCK□□AM1R	●	●	●	●
	F-JCK□□AM1C	●	●	●	●
	F-JCK□□AM1L	●	●	●	●
	F-JCK□□AM2R		●	●	●
	F-JCK□□AM2C		●	●	●
	F-JCK□□AM2L		●	●	●
	F-JCK□□AM3R			●	●
	F-JCK□□AM3C			●	●
	F-JCK□□AM3L			●	●
	F-JCK□□AM4R				●
	F-JCK□□AM4C				●
	F-JCK□□AM4L				●

Clamp arm ordering code

F-JCK 63 AM1C				
① Accessory code	② Cylinder type	③ Bore size	④ Clamping arm	
	Power clamp cylinder (Double acting)	40: Φ 40mm	Blank: No clamping arm	
			AM1: Offset 15mm	R C L Φ 6 Φ 7
			AM3: Offset 45mm	R C L
			Blank: No clamping arm	R C L
			AM1: Offset 15mm	R C L Φ 6 Φ 9
			AM3: Offset 45mm	R C L
		50: Φ 50mm 63: Φ 64mm 80: Φ 80mm	AM2: Offset 15mm	R C L Φ 8 Φ 10.2
			AM4: Offset 45mm	R C L

[Note2] Please refer to the drawing for detailed dimensions of clamping arm. Clamping arm AM1 and AM2 for 80 offset 20mm.

Power clamp cylinder

JSCK Series—Clamp arm

Dimensions of clamp arm

F-JCK40AM1

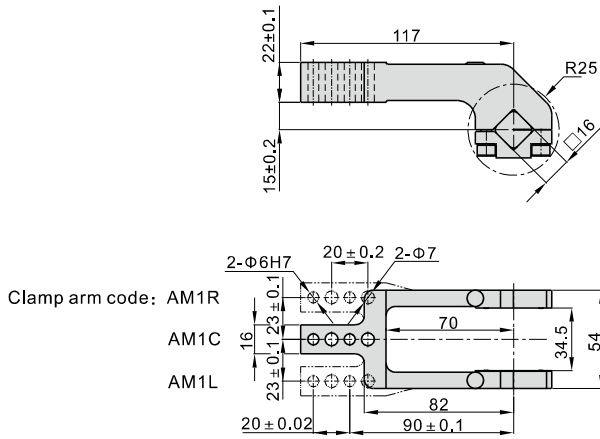

F-JCK40AM3

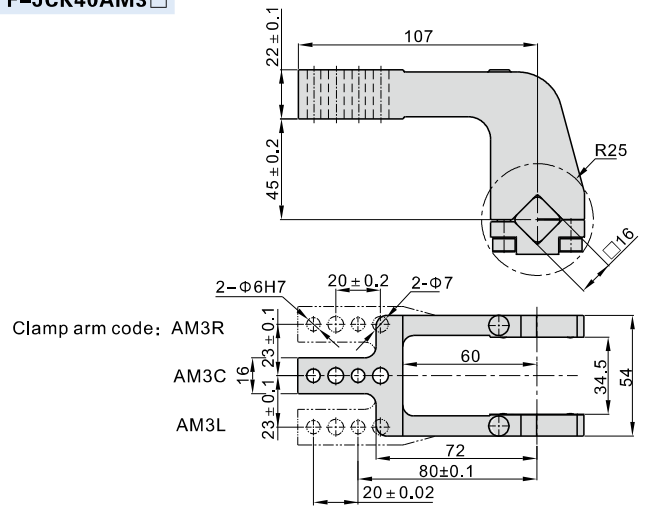

F-JCK50AM1

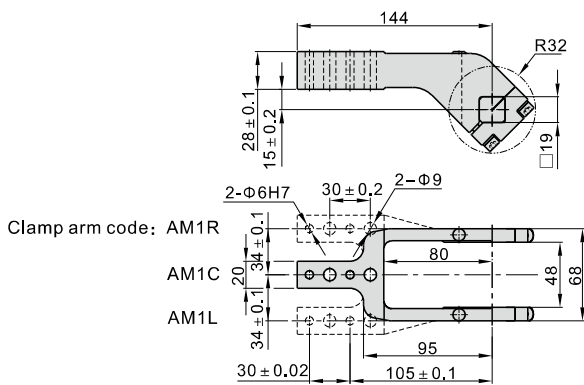

F-JCK50AM2

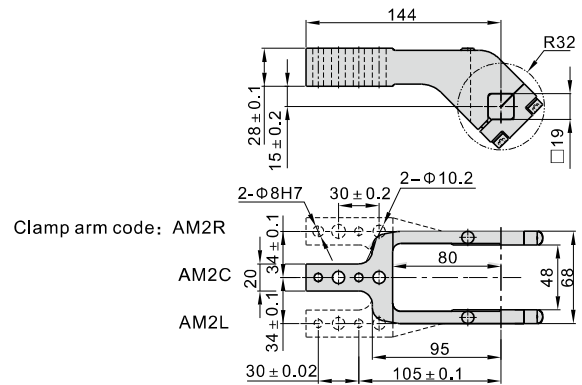

F-JCK50AM3

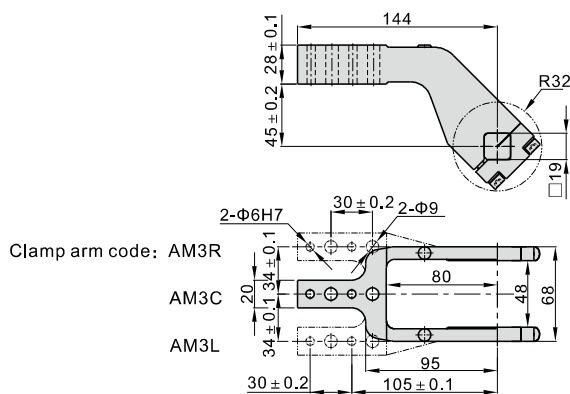

F-JCK50AM4

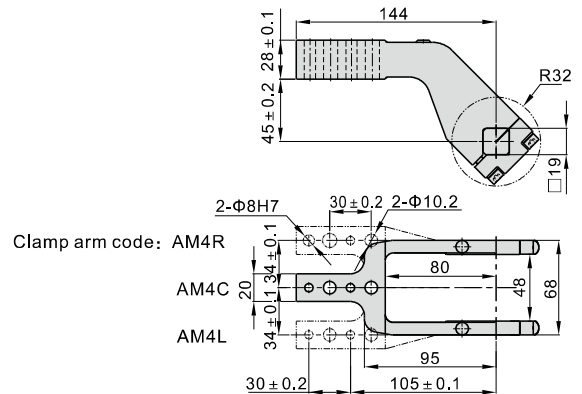

Power clamp cylinder

JSCK Series—Sensor switch



Specification

Operating range	2mm
Voltage range	10~30V DC
Output type	N.O., PNP, NPN
Rated DC	150mA(max)
Switch frequency	30Hz
Shell material	PBT
Switch status indication	Clamping: Red Opening: Yellow
Voltage indication	Green

Ordering code

DS1 KP 63		
① Model	② Output type	③ Bore size
DS1: Sensor switch	KP: PNP KN: NPN	63(Bore size: 40、50、63) 80(Bore size: 80)

Hookup

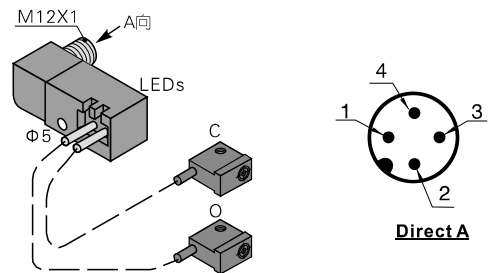
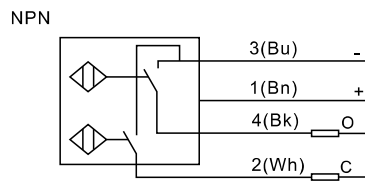
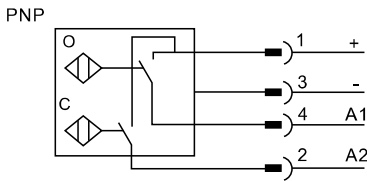

Installation and application of sensor switch

1. Sensor switch is well assembled before leaving factory which is free of adjusting. If you need to change terminals' wiring direction, change new sensor or rearrange angle, please do as follows:

1.1) Steps of changing terminals' wiring direction:

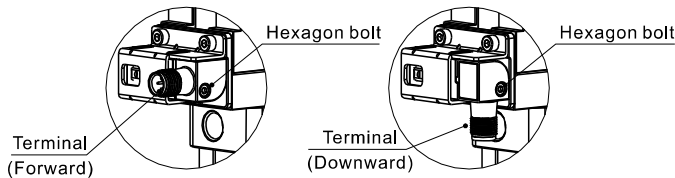

(See figure above.) Unscrew the hexagon bolt→rotate terminals' wiring direction as you need→screw up the hexagon bolt.

1.2) Steps of change new sensor switch:

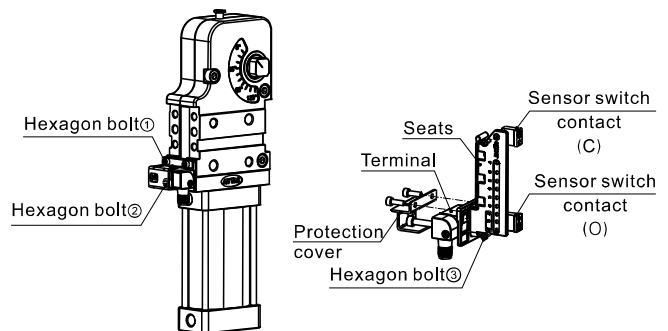

(See figure above.) unscrew two hexagon bolts ①→dismount sensor seats as a whole→unscrew two hexagon bolts ③→dismount two sensor switch contacts(SO1\SO2)→unscrew hexagon bolt ②→remove the sensor switch→choose new sensor switch →replace new sensor switch contact and screw up hexagon bolt ②→replace new wiring box and screw up hexagon bolt ①→finished.

Recommended lock torque of hexagon bolt is listed in the following table:

Bore size	Recommended lock torque of hexagon bolt ①		Recommended lock torque of hexagon bolt ②		Recommended lock torque of hexagon bolt ③	
	Hexagon bolt type	Lock torque(N.m)	Hexagon bolt type	Lock torque(N.m)	Hexagon bolt type	Lock torque(N.m)
40、50	M4 × 0.7	2.0~3.0	M5 × 0.8	4.0~5.0	M3 × 0.5	1.2~1.5
63、80	M4 × 0.7	2.0~3.0				

1.3) Steps of readjusting angle: For more details, see latter contents.

1.4) Sensor switch's connection:

Sensor switch's connection need to use relevant male connector, which have separate male connector, and with wire male connector to be choosed.

The ordering code as below:

Name: On end cable(3 meters length)	Name: L shape cable(3 meters length)	Name: On end connector(rotundity)	Name: L shape connector (rotundity)
Ordering code: X-F-PPVCS	Ordering code: X-F-PPVCL	Ordering code: X-F-PPVCV	Ordering code: X-F-PPVCH



Power clamp cylinder

JSKC Series

Installation and application

1. Mount the cylinder at desired place with bolts and locating pin after choosing a mounting surface. Connect the cylinder and control valve with joint and rubber hose. To adjust the opening and closure speed, our pneumatic power welding clamp is equipped with return stroke air buffering. Buffering cannot function well if the clamping arm is over-weighted so that clamping arm' weight must be within the allowable limit;
2. Using clamping arm beyond the listed in this catalog is forbidden.
3. Workpiece mounting method:
 - 3.1) When only clamping torque is used for clamping:

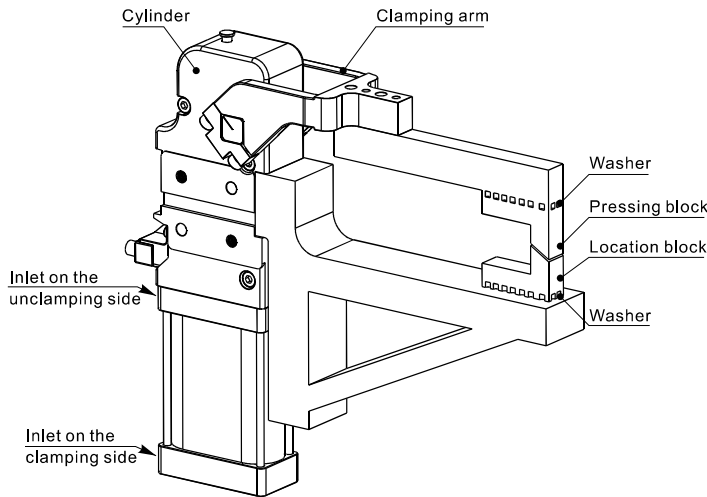

Please follow the steps to mount the workpiece onto the clamping arm:

- A) Clamping the arm:** supply compressed air through the inlet on the clamping side to keep the arm and pressing block at the closure position simultaneously. Make sure the arm is locked up.
- B) Adjusting the clamping gap:** adjust the spacer under the mentioned state to make the pressing block in line with the workpiece's thickness. (At this moment no clamping torque is produced theoretically.)
- C) Applying clamping torque:** Insert the spacer furthermore under the mentioned state until the gap is smaller than the workpiece's thickness and desired clamping torque is produced. (Make sure the mechanism passes the dead position to produce self-locking i.e. the retaining pin is pushed out.)

3.2) When hard braking is used for clamping:

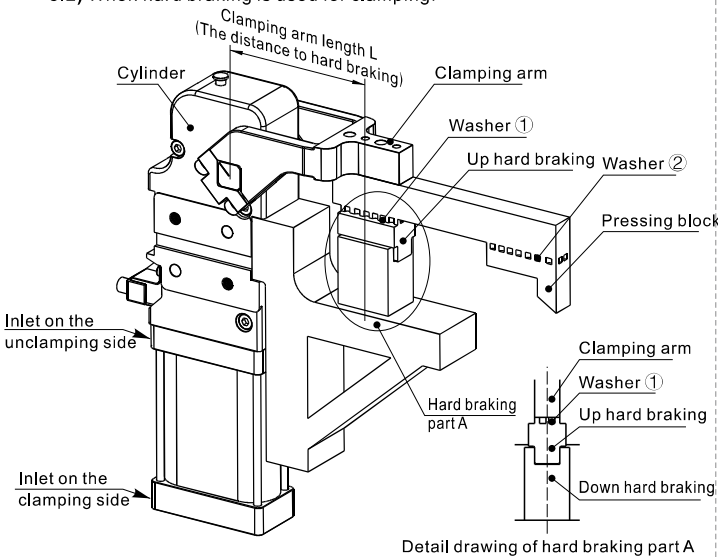

Detail drawing of hard braking part A

Please follow the steps to mount the workpiece onto the clamping arm:

- A) clamping the arm:** supply compressed air through the inlet on the closure side to keep the arm and the braking block at the clamping position simultaneously. Make sure the arm is locked up;

- B) Adjusting the clamping gap:** Adjust washer ① under the mentioned state until the gap between the upside braking block and downside one. (At this moment no clamping torque is produced theoretically.)
- C) Applying clamping torque:** insert the washer ① furthermore under the mentioned state to produce desired clamping torque. (Make sure the mechanism passes the dead position to produce self-locking i.e. the retaining pin is pushed out.)
- D) Adjust washer ②** under the state mentioned in C to make the pressing block in contact with the workpiece.

3.3) When side guide plate is mounted:

Side guide plate is mounted on the clamping arm to prevent transverse movement and make sure that no transverse load is applied and that the arm would not be stuck.

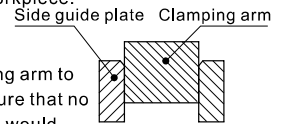

4. Mounting clamping arm:

The clamping arm is already mounted when leaving factory which can be remounted by yourself horizontally or vertically according to your actual need.

4.1) Mounting clamping arm horizontally:

Unscrew 4 hexagon bolts on both sides of the clamping arm to remove V-shaped block and then the clamping arm for substituting your desired one.

When mounting, please note the direction of the indicating line on the pivot.

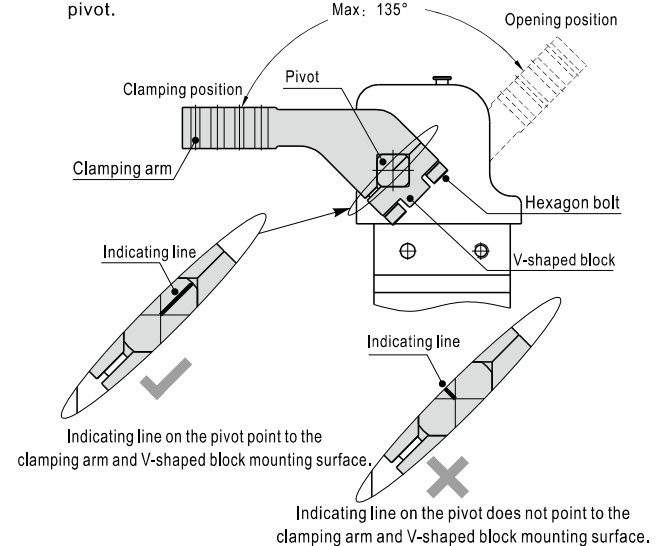

4.2) Mounting clamping arm vertically:

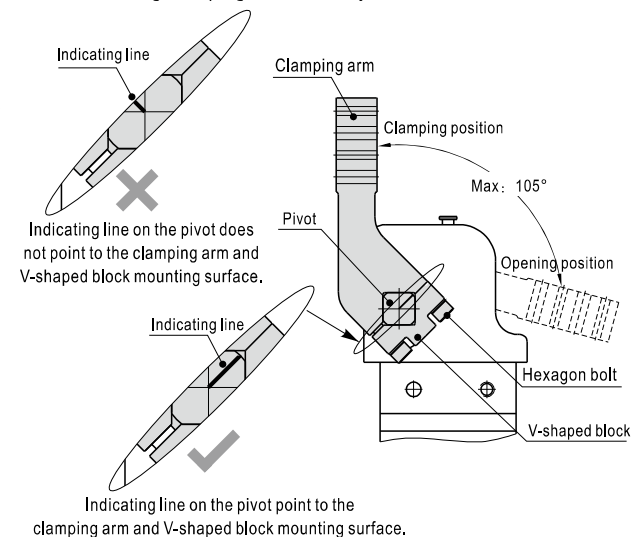

Power clamp cylinder

JSCK Series

4.3) V-shaped block mounting:

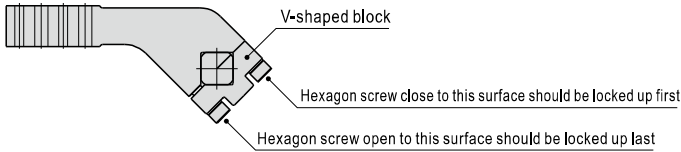

4.4) Holding torque of clamping arm (recommended):

When holding clamping arm, please choose recommended value in the following list:

Bore size	Bolt type	Holding torque (N.m)
40	M6 × 1.0	13.8
50	M6 × 1.0	13.8
63	M8 × 1.25	33.0
80	M10 × 1.5	66.0

5. Self-lock function:

At the end of stroke, the crank-slider mechanism passes the dead point and gets self-locked up. The retaining pin gets pushed up at this moment. Even when compressed air is off, the cylinder can remain at closure state for safety. To open self-locking of the crank-slider mechanism, push down the retaining pin when compressed air is off.

Warning:

Pushing down the retaining pin may cause clamping arm to spring off at closure state.

So when using the pin, please get yourself away from the clamping arm's operation range.

