



Multi-mount cylinder—MD, MK Series

Compendium of MD\MK Series

Six bore size are available
Bore size: 6, 10, 16, 20, 25, 32

Mounted from 6 directions
Cylinder can be mounted from 6 directions, and convenient to install and use.

Front mounting Back mounting
Left mounting Right mounting
Bottom mounting Up mounting

Magnetic switch slots around the cylinder body
There are magnetic switch slots around the cylinder body convenient to install inducting switch.

Mounted side by side
Multitudinous cylinder can be mounted side by side to save space.

Mounted side by side from left Mounted side by side from right

Multi-type cylinder

MD: Multi-mount cylinder (Double acting type)	
MSD: Multi-mount cylinder (Single acting-push type)	
MTD: Multi-mount cylinder (Single acting-pull type)	
MDD: Multi-mount cylinder (Double rod type)	
MDJ: Multi-mount cylinder (Adjustable stroke type)	
MK: Multi-mount cylinder (Double acting no-rotating type)	
MSK: Multi-mount cylinder (Single acting-push no-rotating type)	
MTK: Multi-mount cylinder (Single acting-pull no-rotating type)	
MKD: Multi-mount cylinder (Double rod no-rotating type)	
MKJ: Multi-mount cylinder (Adjustable stroke no-rotating type)	

Criteria for selection: Cylinder thrust

Unit : Newton(N)

Bore size	Rod size	Acting type	Pressure area(mm ²)	Operating pressure(MPa)							
				0.1	0.2	0.3	0.4	0.5	0.6	0.7	
6	3	Single acting	Push side	28.3	-	1.5	2.9	4.3	5.7	7.2	8.6
			Pull side	21.2	-	-	0.8	1.5	2.2	2.9	3.6
		Double acting	Push side	28.3	2.8	5.7	8.5	11.3	14.1	17.0	19.8
			Pull side	21.2	2.1	4.2	6.4	8.5	10.6	12.7	14.8
10	4	Single acting	Push side	78.5	-	3.9	7.9	11.8	15.8	19.7	23.7
			Pull side	66.0	-	1.4	4.1	6.8	9.5	12.2	14.9
		Double acting	Push side	78.5	7.9	15.7	23.6	31.4	39.3	47.1	55.0
			Pull side	66.0	6.6	13.2	19.8	26.4	33.0	39.6	46.2
16	6	Single acting	Push side	201.1	-	10.1	30.2	50.3	70.4	90.5	110.6
			Pull side	172.8	-	8.7	25.9	43.2	60.5	77.8	95.1
		Double acting	Push side	201.1	20.1	40.2	60.3	80.4	100.5	120.6	140.7
			Pull side	172.8	17.3	34.6	51.8	69.1	86.4	103.7	121.0
20	8	Single acting	Push side	314.2	-	15.7	47.1	78.6	110.0	141.4	172.8
			Pull side	263.9	-	13.2	39.6	66.0	92.3	118.7	145.1
		Double acting	Push side	314.2	31.4	62.8	94.2	125.7	157.1	188.5	219.9
			Pull side	263.9	26.4	52.8	79.2	105.6	131.9	158.3	184.7
25	10	Single acting	Push side	490.9	-	24.7	73.8	122.8	179.1	221.0	270.1
			Pull side	412.3	-	20.7	61.9	103.1	144.4	185.6	226.8
		Double acting	Push side	490.9	49.1	98.2	147.3	196.3	245.4	294.5	343.6
			Pull side	412.3	41.2	82.5	123.7	164.9	206.2	247.4	288.6
32	12	Single acting	Push side	804.2	-	40.2	120.7	201.1	281.5	361.9	442.4
			Pull side	691.2	-	34.7	103.8	173.0	242.1	311.2	380.3
		Double acting	Push side	804.2	80.4	160.8	241.3	321.7	402.1	482.5	563.0
			Pull side	691.2	69.1	138.2	207.3	276.5	345.6	414.7	483.8

Installation and application



- When load changes in the work, the cylinder with abundant output capacity shall be selected.
- Relative cylinder with high temperature resistance or corrosion resistance shall be chosen under the condition of high temperature or corrosion;
- Necessary protection measure shall be taken in the environment with higher humidity, much dust or water drops, oil dust and welding dregs.
- Dirty substances in the pipe must be cleared away before cylinder is connected with pipeline to prevent the entrance of particles into the cylinder.
- The medium used by cylinder shall be filtered to 40μm or below.
- As both of the front cover and piston of the cylinder are short, typically too large stroke can not be selected.
- Anti-freezing measure shall be adopted under low temperature environment to prevent moisture freezing.
- The cylinder shall avoid the influence of side load in operation maintain the normal work of cylinder and extend the service life.
- If the cylinder is dismantled and stored for a long time, pay attention to conduct anti-rust treatment to the surface. Anti-dust caps shall be added in air inlet and outlet ports.



Multi-mount cylinder

MK Series



Symbol

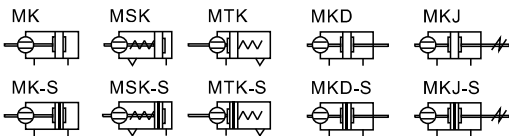

Product feature

1. Manufactured by our enterprise.
2. There are several fixation ways for the cylinder, and also convenient to install and use.
3. Several cylinders can be assembled together to effectively save the installation space.
4. The guide precision of piston rod is high and no additional lubricant is needed.
5. Fixed block is attached to piston rod, which prevents it from rotating.
6. Various cylinders are available for your choice.
7. The seal material with high temperature resistance is adopted, operating temperature range is 0~150°C.(Option).

Specification

Bore size(mm)	6	10	16	20	25	32
Acting type	MK/MKD/MKJ MSK/MTK		Double acting Single acting			
Fluid	Air(to be filtered by 40µm filter element)					
Operating pressure	Double acting 0.2~1.0MPa(28~145psi)		0.15~1.0MPa(22~145psi)			
	Single acting		0.2~1.0MPa(28~145psi)			
Proof pressure	1.5MPa(215psi)					
Temperature °C	-20~70					
Speed range mm/s	Double acting : 30~500		Single acting : 50~500			
Stroke tolerance	+1.0 0					
Cushion type	Bumper					
Port size [Note]	M5×0.8					1/8"

[Note1] PT thread, G thread are available.
Add) Refer to P362 for detail of sensor switch.

Stroke

Bore size (mm)	Standard stroke (mm)						Max.std stroke			
6	Double acting	5	10	15	20	25	30	35	35	
	Single acting	5	10	15	20					20
10	Double acting	5	10	15	20	25	30	35	35	
	Single acting	5	10	15	20					20
16	Double acting	5	10	15	20	25	30	40	50	50
	Single acting	5	10	15	20					20
20	Double acting	5	10	15	20	25	30	40	50	60
	Single acting	5	10	15	20					20
25	Double acting	5	10	15	20	25	30	40	50	60
	Single acting	5	10	15	20					20
32	Double acting	5	10	15	20	25	30	40	50	60
	Single acting	5	10	15	20					20

- [Note] 1. Please contact the company for other special strokes.
2. The dimensions of non-std stroke cylinder has the same dimensions as the next longer stroke std. stroke cylinder. e.g. 23mm stroke cylinder has the same dimensions of 25 std. stroke cylinder.

Ordering code

MK 32 × 30 S □

MKD 32 × 30 S □

MKJ 32 × 30-30 S □

① ② ③ ④ ⑤ ⑥

① Model	② Bore size	③ Stroke	④ Adjustable stroke	⑤ Magnet	⑥ Thread type [Note1]
MK: Multi-mount cylinder(Double acting no-rotating type)	6 10 16 20 25 32	Refer to stroke table for details	No this code	Blank: Without magnet S: With magnet	Blank: PT G : G
MSK: Multi-mount cylinder(Single acting-push no-rotating type)					
MTK: Multi-mount cylinder (Single acting-pull no-rotating type)					
MKD: Multi-mount cylinder(Double rod no-rotating type)			10 20 30		
MKJ: Multi-mount cylinder(Adjustable stroke no-rotating type)					

[Note1] Standard thread is blank here.

Inner structure and material of major parts

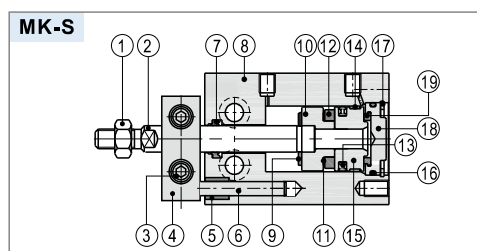

NO.	Item	Material	NO.	Item	Material
1	Rod nut	Carbon steel/ Stainless steel	11	Magnet washer	NBR
2	Piston rod	Stainless steel/S45C	12	Magnet	Sintered metal(Neodymium-iron-boron)
3	Screw	Carbon steel	13	Piston seal	NBR
4	No-rotating plate	Aluminum alloy	14	Wear ring	Wear resistant material
5	Bushing	Brass	15	Piston	Aluminum alloy
6	Fixed rod	Stainless steel	16	O-ring	NBR
7	Rod packing	NBR	17	C-clip	Spring steel
8	Body	Aluminum alloy	18	Back cover	Aluminum alloy
9	Bumper	TPU	19	Bumper	TPU
10	Magnet holder	Aluminum alloy			

Multi-mount cylinder

MK Series

Dimensions

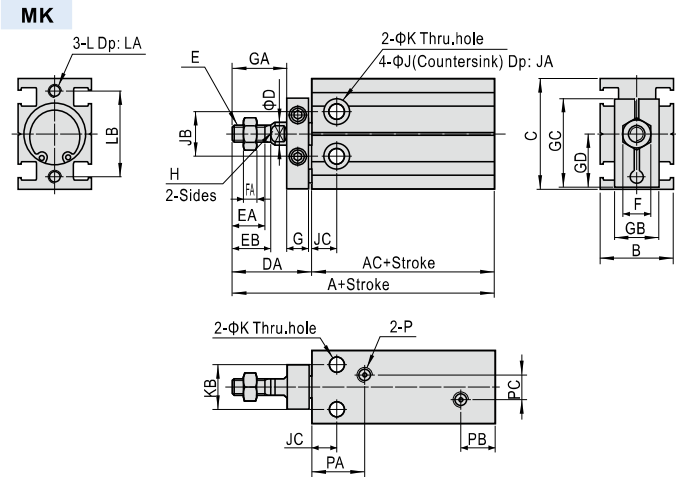

Bore size\Item	Without magnet		With magnet		B	C	D	DA	E
	A	AC	A	AC					
6	51	33	51	33	16.5	22	3	18	M3×0.5
10	57	36	57	36	16.5	24	4	21	M4×0.7
16	56	30	66	40	20	32	6	26	M5×0.8
20	65	36	75	46	26	40	8	29	M6×1.0
25	73	40	83	50	32	50	10	33	M8×1.25
32	84	42	94	52	40	62	12	42	M10×1.25

Bore size\Item	EA	EB	F	FA	G	GA	GB	GC	GD	H	J	JA
6	7	8	5.5	2.5	8	9	11	19	10.7	-	6	5
10	10	11	7	2	8	12	13	20.5	11.6	-	6	5.5
16	11	12.5	8	4	8	17	13	26.5	15.6	5	7.5	6.5
20	12	14	10	5	8	20	16	32	19.5	6	9.5	8
25	15.5	18	12	6	10	22	19	40	24.5	8	9.5	9
32	19.5	22	17	6	12	29	24	49	30.5	10	11	11.5

Bore size\Item	JB	JC	K	KB	L	LA	LB	P	PA	PB	PC
6	10	7	3.3	7	M3×0.5	5	17	M5×0.8	14	10	-
10	11	7	3.3	9	M3×0.5	5	18	M5×0.8	15.5	10	-
16	14	7	4.5	12	M4×0.7	5	25	M5×0.8	14.5	10	3
20	16	9	5.5	16	M5×0.8	7.5	30	M5×0.8	19.3	9.5	9
25	20	10	5.5	20	M5×0.8	8	38	M5×0.8	20.5	8.5	12
32	24	11	6.5	24	M6×1.0	9	48	1/8"	22	12.5	13

MSK

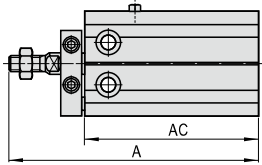

Item	A(Without magnet)				A(With magnet)				AC(Without magnet)				AC(With magnet)			
	5St	10St	15St	20St	5St	10St	15St	20St	5St	10St	15St	20St	5St	10St	15St	20St
6	61	66	76	81	61	66	76	81	43	48	58	63	43	48	58	63
10	67	72	82	87	67	72	82	87	46	51	61	66	46	51	61	66
16	71	76	91	96	81	86	101	106	45	50	65	70	55	60	75	80
20	80	85	100	105	90	95	110	115	51	56	71	76	61	66	81	86
25	88	93	108	113	98	103	118	123	55	60	75	80	65	70	85	90
32	99	104	119	124	109	114	129	134	57	62	77	82	67	72	87	92

MTK

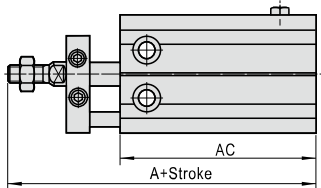

Remark) The unmarked dimension is the same as MK standard type.

MKD

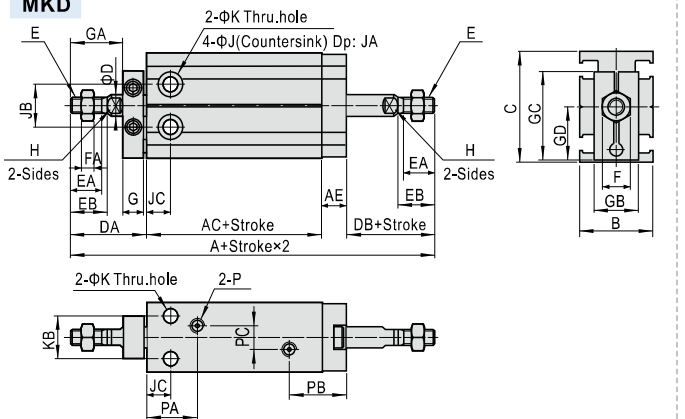

MKJ

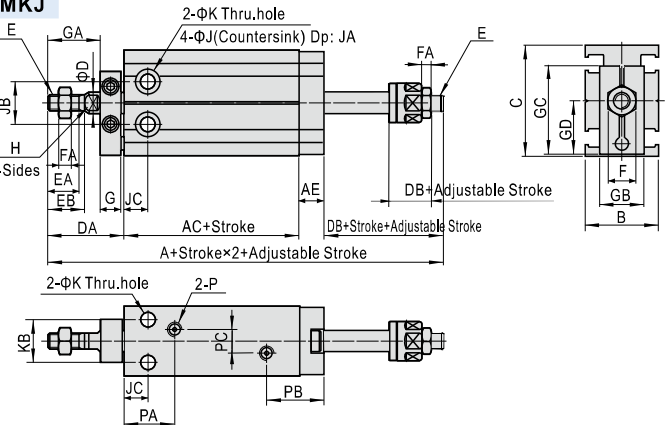

Bore size\Item	A(Without magnet)		A(With magnet)		AC (Without magnet)	AC (With magnet)	AE	B	C	D	DA	DB		E
	MKD	MKJ	MKD	MKJ								MKD	MKJ	
6	75	75	75	75	38	38	6	16.5	22	3	18	13	13	M3×0.5
10	79	78	79	78	36	36	6	16.5	24	4	21	16	14.7	M4×0.7
16	79.5	80.5	89.5	90.5	30	40	7.5	20	32	6	26	16	17	M5×0.8
20	93	95	103	105	36	46	9	26	40	8	29	19	21	M6×1.0
25	105	107	115	117	40	50	9	32	50	10	33	23	25	M8×1.25
32	121	121	131	131	42	52	10	40	62	12	42	27	27	M10×1.25

Bore size\Item	EA	EB	F	FA	G	GA	GB	GC	GD	H	J	JA	JB	JC	K	KB	P	PA	PB	PC
6	7	8	5.5	2.5	8	9	11	19	10.7	-	6	5	10	7	3.3	7	M5×0.8	14	16	-
10	10	11	7	2	8	12	13	20.5	11.6	-	6	5.5	11	7	3.3	9	M5×0.8	15.5	16	-
16	11	12.5	8	4	8	17	13	26.5	15.6	5	7.5	6.5	14	7	4.5	12	M5×0.8	14.5	17.5	3
20	12	14	10	5	8	20	16	32	19.5	6	9.5	8	16	9	5.5	16	M5×0.8	19.3	18.5	9
25	15.5	18	12	6	10	22	19	40	24.5	8	9.5	9	20	10	5.5	20	M5×0.8	20.5	17.5	12
32	19.5	22	17	6	12	29	24	49	30.5	10	11	11.5	24	11	6.5	24	1/8"	22	22.5	13

