



# MPG Series Plate Cylinder

## Compendium of MPG Series

**Five bore size are available**  
Bore size: 6, 8, 10, 12, 16

**Magnetic switch slots around the cylinder body**  
There are magnetic switch slots around the cylinder body convenient to install inducting switch.

**Multi-type cylinder**

MPG: Standard plate cylinder (double acting)	
MPGH: Hinge mounting type cylinder (double acting)	

**Two kinds of rod type**

Male thread

No thread

**Three kinds of mounting type**

LB Type

FA Type

SDB Type

**Four kinds of cylinder joints**

I Knuckle

Y Knuckle

FC Rubber bumper (flat head)

RC Rubber bumper (ball head)

### Criteria for selection: Cylinder thrust

Unit : Newton(N)

Model	Bore size	Rod size	Acting type	Pressure area(mm <sup>2</sup> )	Operating pressure(MPa)							
					0.1	0.2	0.3	0.4	0.5	0.6	0.7	
MPG MPGH	6	3	Double acting	Push side	28.3	2.8	5.7	8.5	11.3	14.2	17.0	19.8
				Pull side	21.2	2.1	4.2	6.4	8.5	10.6	12.7	14.8
	8	4	Double acting	Push side	50.3	5.0	10.1	15.1	20.1	25.2	30.2	35.2
				Pull side	37.7	3.8	7.5	11.3	15.1	18.9	22.6	26.4
	10	4	Double acting	Push side	78.5	7.9	15.7	23.6	31.4	39.3	47.1	55.0
				Pull side	65.9	6.6	13.2	19.8	26.4	33.0	39.5	46.1
	12	6	Double acting	Push side	113.0	11.3	22.6	33.9	45.2	56.5	67.8	79.1
				Pull side	84.7	8.5	17.0	25.4	33.9	42.4	50.8	59.3
	16	6	Double acting	Push side	201.0	20.1	40.2	60.3	80.4	100.5	120.6	140.7
				Pull side	172.7	17.3	34.5	51.8	69.1	86.4	103.6	120.9

### Installation and application



- When load changes in the work, the cylinder with abundant output capacity shall be selected.
- Relative cylinder with high temperature resistance or corrosion resistance shall be chosen under the condition of high temperature or corrosion.
- Necessary protection measure shall be taken in the environment with higher humidity, much dust or water drops, oil dust and welding dregs.
- Dirty substances in the pipe must be eliminated before cylinder is connected with pipeline to prevent the entrance of particles into the cylinder.
- The medium used by cylinder shall be filtered to 40μm or below.
- As both of the front cover and piston of the cylinder are short, typically too large stroke can not be selected.
- Anti-freezing measure shall be adopted under low temperature environment to prevent moisture freezing.
- The cylinder shall avoid the influence of side load in operation to maintain the normal work of cylinder and extend the service life.
- If the cylinder is dismantled and stored for a long time, please conduct anti-rust treatment to the surface. Anti-dust caps shall be added in air inlet and outlet ports. The front and back cover can not be dismantled, which shall be especially noticed.



# Plate Cylinder

## MPG Series



### Specification

Bore size(mm)	6	8	10	12	16
Acting type	Double acting				
Fluid	Air(to be filtered by 40µm filter element)				
Operating pressure	0.15~0.7MPa(22~100psi)				
Proof pressure	1.2MPa(175psi)				
Mounting type	Basic, FA, LB, SDB				
Temperature °C	-20~70				
Speed range mm/s	30~500				
Stroke tolerance	+1.0 0				
Cushion type	Bumper				
Port size	M3×0.5			M5×0.8	

Add) Refer to P362 for detail of sensor switch.

### Symbol



### Product feature

1. It is compact, small size and light weight. It is easy to install and dismantle.
2. The guide precision of piston rod is high and no additional lubricant is needed.
3. Advanced rubber coating process is applied to the back cover.
4. Mounting accessories with various specifications are optional.
5. With magnet type is of the feature of position sensing.
6. There are magnetic switch slots around the cylinder body, which is convenient to install inducting switch.
7. Cylinders of various specifications are optional.

### Stroke

Bore size (mm)	Standard stroke (mm)										Max.std stroke	
6	5	10	15	20	25						25	
8	5	10	15	20	25	30	35	40				40
10	5	10	15	20	25	30	35	40				40
12	5	10	15	20	25	30	35	40				40
16	5	10	15	20	25	30	35	40				40

[Note] Please contact the company for other special strokes.

### Ordering code

① Model	② Bore size	③ Stroke	④ Magnet	⑤ Rod type	⑥ Mounting type
MPG: Standard plate cylinder (double acting)	6 8 10 12 16	Refer to stroke table for details	Blank: Without magnet S: With magnet	Blank: Male thread N: No thread	Blank: No accessories
MPGH: Hinge mounting type cylinder (double acting)					LB: LB type
					FA: FA type
					Blank: No accessories
					SDB: SDB type

### Inner structure and material of major parts

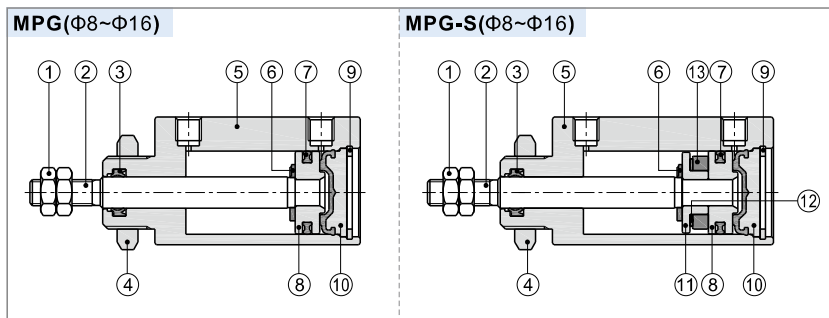

NO.	Item	Material
1	Rod nut	Stainless steel
2	Piston rod	Stainless steel
3	Front cover packing	NBR
4	Front cover nut	Carbon steel
5	Body	Aluminum alloy
6	Bumper	TPU
7	Piston	Aluminum alloy(Φ16) Brass(Others)
8	Piston seal	NBR
9	clip	Spring steel
10	Back cover	Aluminum alloy & Rubber
11	Magnet holder	Stainless steel(Φ6)/Brass(Φ8~Φ12) Aluminum alloy(Φ16)
12	Magnet washer	NBR
13	Magnet	Sintered metal (Neodymium-iron-boron)

# Plate Cylinder

## MPG Series

### Dimensions

#### MPG/MPG-S

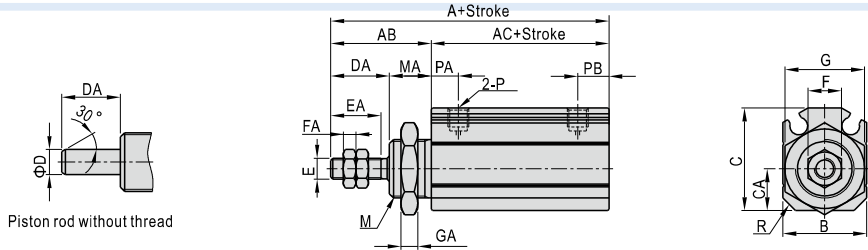

Bore size\Item	A	AC	A	AC	AB	B	C	CA	D	DA	E	EA	F	FA	G	GA	M	MA	P	PA	PB	R
	Without magnet	With magnet	Without magnet	With magnet																		
6	33	16	38	21	17	14	16.5	6	3	9	M3×0.5	7	5.5	2.4	13	4	M10×1.0	8	M3×0.5	5.5	6.5	2
8	38	18	43	23	20	14.5	17.5	7	4	12	M4×0.7	10	7	3	17	4	M12×1.0	8	M3×0.5	6	7	2
10	39.5	19.5	44.5	24.5	20	15	19	7	4	12	M4×0.7	10	7	3	17	4	M12×1.0	8	M3×0.5	6	7	2.5
12	43.5	19.5	48.5	24.5	24	17	21.5	8.5	6	14	M5×0.8	12	8	3	19	4	M14×1.0	10	M5×0.8	6.5	7.5	2.5
16	43.5	19.5	48.5	24.5	24	20	24.5	10	6	14	M5×0.8	12	8	3	19	4	M14×1.0	10	M5×0.8	6.5	7.5	3

#### MPGH/MPGH-S

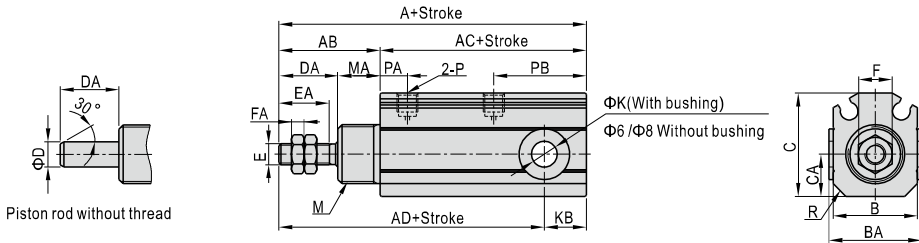

Bore size\Item	A	AC	AD	A	AC	AD	AB	B	BA	C	CA	D	DA	E	EA	F	FA	K	KB	M	MA	P	PA	PB	R
	Without magnet	With magnet	Without magnet	With magnet																					
6	38	21	34	43	26	39	17	14	-	16.5	6	3	9	M3×0.5	7	5.5	2.4	$3^{+0.05}_0$	4	M10×1.0	8	M3×0.5	5.5	11.5	2
8	46	26	41	51	31	46	20	14.5	-	17.5	7	4	12	M4×0.7	10	7	3	$4^{+0.05}_0$	5	M12×1.0	8	M3×0.5	6	15	2
10	50.5	30.5	44	55.5	35.5	49	20	15	17	19	7	4	12	M4×0.7	10	7	3	$5^{+0.065}_0$	6.5	M12×1.0	8	M3×0.5	6	18	2.5
12	58	34	48	63	39	53	24	17	19	21.5	8.5	6	14	M5×0.8	12	8	3	$6^{+0.065}_0$	10	M14×1.0	10	M5×0.8	6.5	22	2.5
16	58	34	48	63	39	53	24	20	22	24.5	10	6	14	M5×0.8	12	8	3	$6^{+0.065}_0$	10	M14×1.0	10	M5×0.8	6.5	22	3

### Installation and application

1. Select the plate thickness and tightening torque of the front cover thread according to the table below:

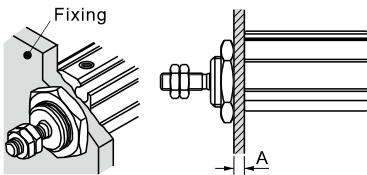

Bore size	Front cover thread	Maximum allowable torque(N.m)	Maximum thickness(A)
6	M10×1.0	12.5	4
8	M12×1.0	21.0	4
10	M12×1.0	21.0	4
12	M14×1.0	34.0	5
16	M14×1.0	34.0	5

2. The extra torque produced by the load at the piston rod end cannot exceed the allowable value specified in the table below. Otherwise may cause damage to the cylinder or reduce the service life.

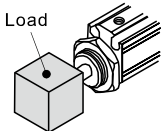

Bore size	Piston rod thread	Maximum allowable torque(N.m)
6	M3×0.5	0.3
8	M4×0.7	0.8
10	M4×0.7	0.8
12	M5×0.8	1.6
16	M5×0.8	1.6

3. Allowable Rod End Lateral Load

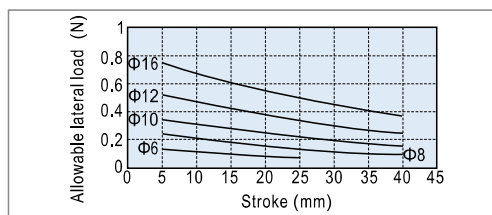
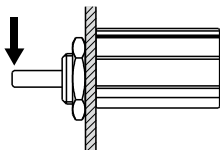

# Plate Cylinder

## MPG Series

### List for ordering code of accessories

Accessories Bore size	Mounting accessories			Knuckle				Sensor switch		
	LB	FA	SDB	FC	RC	I	Y	CMSH	DMSH	EMSH
6	F-MPG6LB	F-MPG6FA	F-MPG6SDB	F-MPG6FC	F-MPG6RC	F-M3×050I	F-M3×050Y	CMSH	DMSH	EMSH
8	F-MPG10LB	F-MPG10FA	F-MPG8SDB F-MPG10SDB	F-MPG10FC	F-MPG10RC	F-M4×070I	F-M4×070Y			
10										
12	F-MPG16LB	F-MPG16FA	F-MPG12SDB F-MPG16SDB	F-MPG16FC	F-MPG16RC	F-M5×080I	F-M5×080Y			
16										

### Accessory selection

Cylinder model	Accessories	Mounting accessories [Note1]			Knuckle [Note2]				Sensor switch		
		LB	FA	SDB	I	Y	FC	RC	CMSH	DMSH	EMSH
MPG	No magnet	•	•	×	•	•	•	•	×	×	×
	With magnet	•	•	×	•	•	•	•	•	•	•
MPGH	No magnet	×	×	•	•	•	•	•	×	×	×
	With magnet	×	×	•	•	•	•	•	•	•	•

### Material of accessories

Accessories Bore size	Mounting accessories			Knuckle			
	LB	FA	SDB	I	Y	FC	RC
6~16	△	△	△	◇	◇	□	□

△—SPCC ; □—POM ; ◇—Carbon steel

[Note1] SDB is attached with relevant PIN.

[Note2] Please refer to P358~361 for knuckle detail.

### Dimensions

#### LB

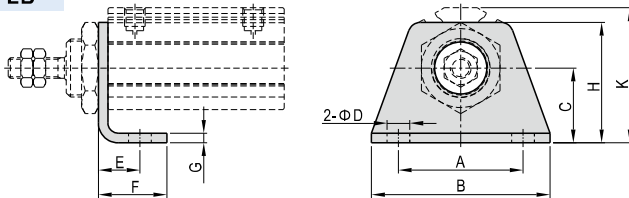

Bore size\Item	A	B	C	D	E	F	G	H	K
6	20	28	11	3.4	6.5	10.5	1.5	19	21.5
8	24	33	13	4.5	7	12	1.5	22	23.5
10	24	33	13	4.5	7	12	1.5	22	25
12	30	43	18	5.5	10	16.5	2.5	29	31
16	30	43	18	5.5	10	16.5	2.5	29	32.5

#### FA

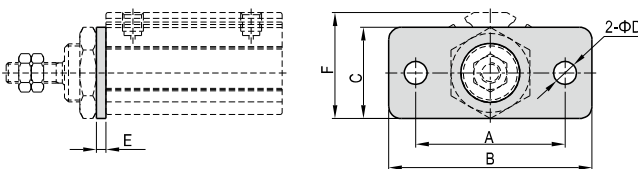

Bore size\Item	A	B	C	D	E	F
6	24	32	16	3.4	1.5	18.5
8	28	37	18	4.5	1.5	19.5
10	28	37	18	4.5	1.5	21
12	36	49	22	5.5	2.5	24
16	36	49	22	5.5	2.5	25.5

#### FC/RC

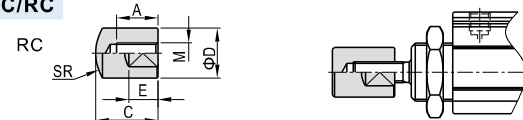

Bore size\Item	A	B	C	D	E	M	SR
6	6	6	11	8	5	M3×0.5	8
8	8	8	13	10	6	M4×0.7	10
10	8	8	13	10	6	M4×0.7	10
12	10	10	15	12	7	M5×0.8	12
16	10	10	15	12	7	M5×0.8	12

#### SDB

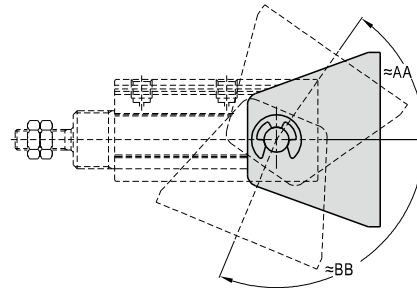
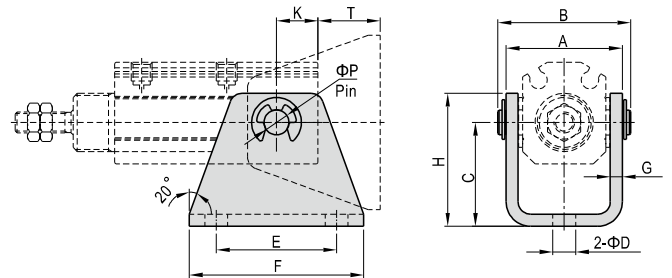

Bore size\Item	A	AA*	B	BB*	C	D	E	F	G	H	K	T	P
6	18.5	55°	21.5	110°	16	3.4	18	26	1.5	20	4	12	3
8	19	55°	23	110°	18	4.5	21	30	1.5	23	5	13	4
10	20.5	65°	24.1	110°	20	4.5	24	33	1.5	25.5	6.5	13.5	5
12	25	55°	29	110°	25	5.5	26	39	3	32	10	15	6
16	28	55°	32	110°	25	5.5	29	42	3	32	10	15	6

\*Note: AA and BB are for reference only.

Specific value depends on the actual situation.