

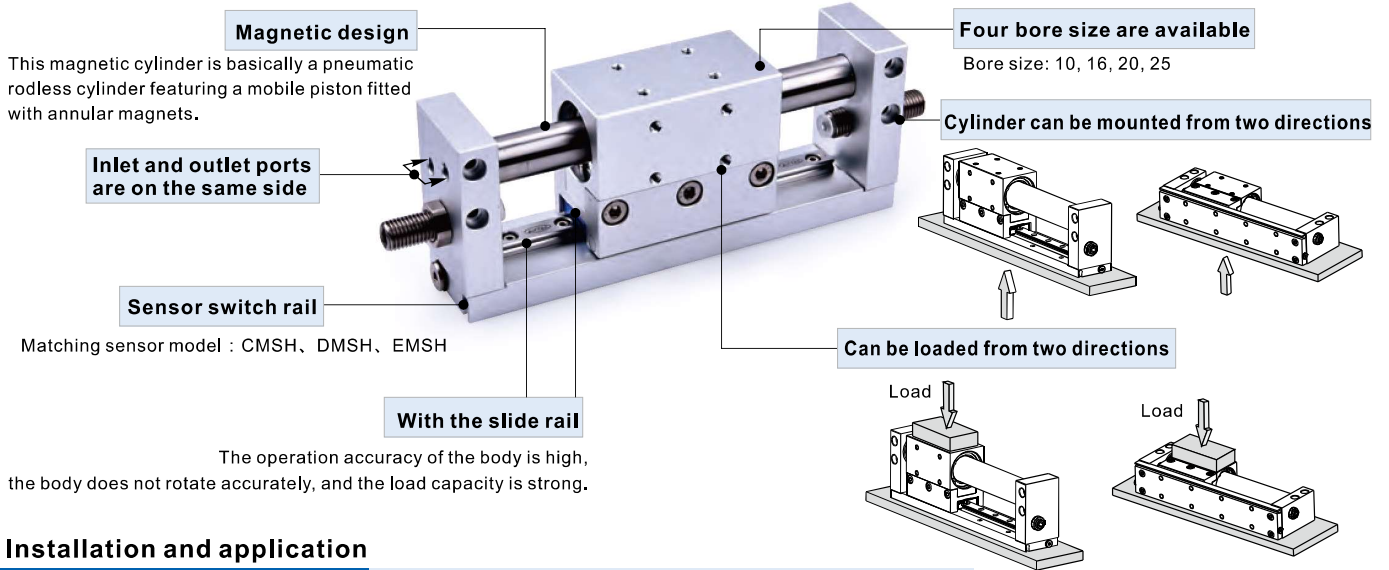

# Rodless magnetic cylinder(With Linear guide)—RMH Series

## Compendium of RMH Series



## Installation and application

1. The maxi load to move must be less than the theoretical holding force.

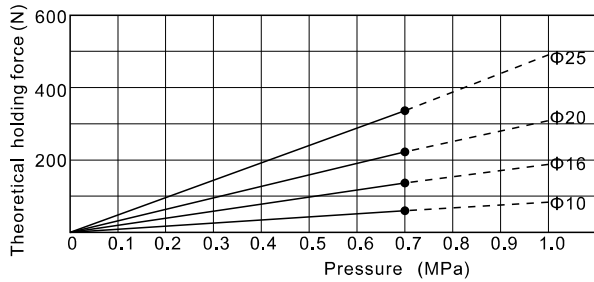

2. The relation between loading and stroke as below (Loading center and slide table center must be superposition)

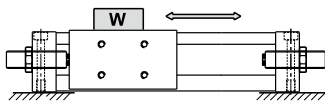

Bore size	Max.Load W(kg)	Stroke scope
10	1.4	~200mm
16	3	~300mm
20	3.6	~500mm
25	4.8	~500mm

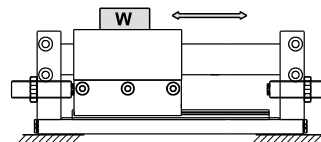
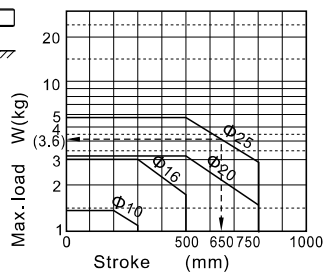

Bore size	Max.Load W(kg)	Stroke scope
10	2.4	~200mm
16	5	~300mm
20	6	~500mm
25	8	~500mm

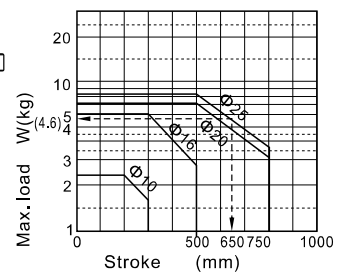

3. About adjusting screw:

RMH series is compacted with two adjusting screws, but you can replace them with oil shock absorber by conditions.

Bore size	Shock absorber type
10	ACA0806-1
16	ACA1007-1
20	ACA1007-1
25	ACA1412-1

4. When use external limiter to stop load middle way: please refer to RMS series.

5. Dirty substances in the pipe must be eliminated before cylinder is connected with pipeline to prevent the entrance of impurities into the cylinder.

6. The medium used by cylinder shall be filtered to 40μm or below.

7. If the cylinder is dismantled and stored for a long time, pay attention to conduct anti-rust treatment to the surface.

Anti-dust jam cap shall be added in air inlet and outlet ports.

8. Non-magnetically conductive materials are recommended for workpieces fitted to the cylinder, otherwise the lifetime may be halved if magnetically conductive materials are used.



# Rodless magnetic cylinder(With Linear guide)

## RMH Series



### Specification

Bore size(mm)	10	16	20	25
Acting type	Double acting			
Fluid	Air(to be filtered by 40μm filter element)			
Operating pressure	0.2~0.7MPa(28~100psi)(2~7bar)			
Proof pressure	1.2MPa(175psi)(12.0bar)			
Temperature °C	-20~70			
Speed range mm/s	50~400			
Stroke tolerance mm	0~250 <sup>+1.0</sup> <sub>0</sub> 251~800 <sup>+1.5</sup> <sub>0</sub>			
Cushion type	Bumper			
Port size [Note1]	M5×0.8			1/8"
Safe holding force N	55	140	220	345

[Note1] PT thread, G thread and NPT thread are available.

### Symbol

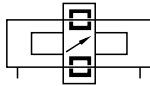

### Stroke

Bore size (mm)	Standard stroke (mm)													
10	50	100	150	200	250	300								
16	50	100	150	200	250	300	350	400	450	500				
20	50	100	150	200	250	300	350	400	450	500	600	700	750	800
25	50	100	150	200	250	300	350	400	450	500	600	700	750	800

[Note] Consult us for non-standard stroke.

### Product feature

1. This magnetic cylinder is basically a pneumatic rodless cylinder featuring a mobile piston fitted with annular magnets. The mobile carriage is also equipped with magnets to provide magnetic coupling (carriage/piston). The carriage slide freely along the main tube.
2. It is dust-proof as the isolation between the carriage and piston.
3. It is compact in space.
4. The non adjustable rubber bumpers and the adjustable pneumatic cushioning on both ends of the cylinder ensure the smooth action.
5. With the slide rail, the operation accuracy of the body is high, the body does not rotate accurately, and the load capacity is strong.

### Ordering code

RMH 20 ×200 S □

① ② ③ ④ ⑤

① Model	② Bore Size	③ Stroke [Note1]	④ Magnet	⑤ Thread type [Note2]
RMH: Rodless magnetic cylinder (With linear guide)	10 16 20 25	Refer to stroke table for details	S: With magnet	Blank : PT thread G : G thread T : NPT thread

[Note1] Consult us for non-standard stroke.

[Note2] Blank on thread code means metric M thread. There is only metric thread for Φ10/Φ16, if NPT or G thread is needed, please consult.

# Rodless magnetic cylinder (With Linear guide)

## RMH Series

### Inner structure and material of major parts

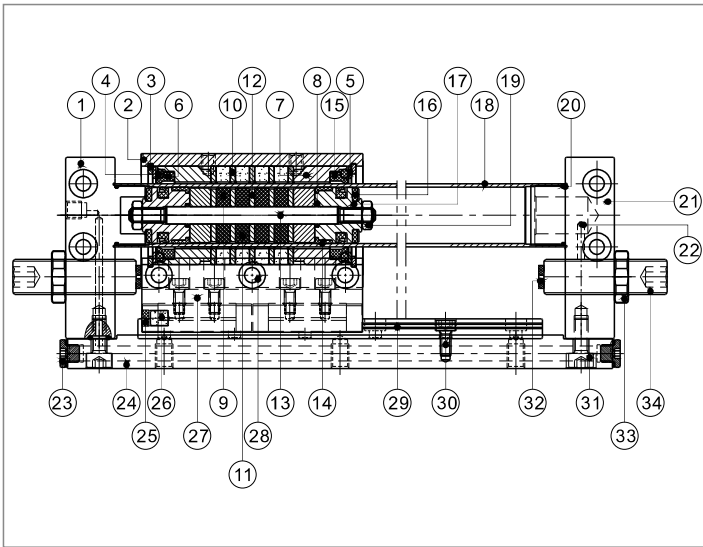

NO.	Item	Material	NO.	Item	Material
1	End cover	Aluminum alloy	18	Barrel	Stainless steel
2	Body	Aluminum alloy	19	Nut	Stainless steel
3	C Clip	TPU	20	O-ring	NBR
4	O-ring	NBR	21	End cover	Aluminum alloy
5	Washer	Stainless steel	22	Steel ball	Stainless steel
6	Scraping dust ring	Plastics	23	Pluger screw	Carbon steel
7	Cover	Aluminum alloy	24	Fixed block	Aluminum alloy
8	O-ring	NBR	25	Push block	Plastics
9	Magnet	Rare-earth material	26	Magnet	Rare-earth material
10	Magnet washer	Carbon steel	27	Joining block	Aluminum alloy
11	Magnet	Rare-earth material	28	Bolt	Alloy steel
12	Magnet washer	Carbon steel	29	Linear rail	-
13	Connecting rod	Stainless steel	30	Bolt	Alloy steel
14	Wear ring	Wear resistant material	31	Bolt	Alloy steel
15	Piston seal	TPU	32	Bumper	TPU
16	Bumper	NBR	33	Nut	Alloy steel
17	Piston	Aluminum alloy	34	Bolt	Alloy steel

### Dimensions

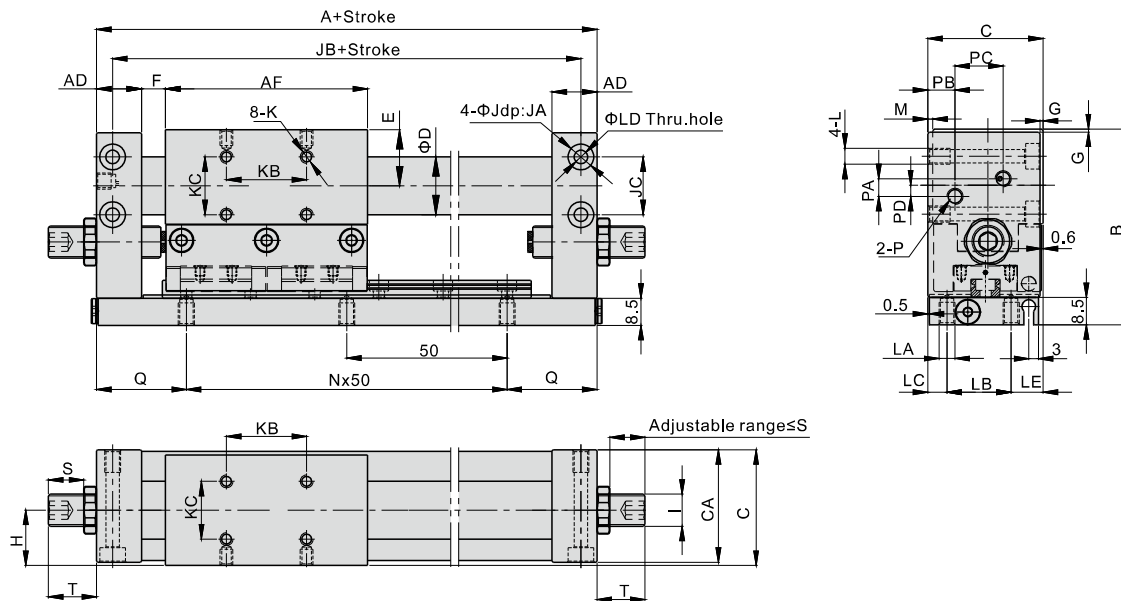

Type/Item	A	AD	AF	B	C	CA	D	E	F	G	H	I	J	JA	JB	JC	K	KB	KC	L	LA	LB	LC
RMH10	86	10.5	52	52	30	29	12	14	6.5	1	14	M8X1.0	6	3.5	78	14	M3X0.5dp:4	20	15	M4X0.7dp:6	M4X0.7dp:6	16	4
RMH16	106	14	63	61	36	35	18	17.5	7.5	1	17	M10X1.0	8	4.5	96	18	M4X0.7dp:5	25	18	M5X0.8dp:7	M5X0.8dp:7	20	6
RMH20	124	14	76	71	39	38	22.8	20	10	1	18.5	M10X1.0	9.5	5.5	112	17	M4X0.7dp:5	40	22	M6X1.0dp:8	M6X1.0dp:8	22	5
RMH25	137	17.5	77	76	45	43	27.8	22.5	12.5	2	21.5	M14X1.5	9.5	5.5	124	20	M5X0.8dp:6	40	28	M6X1.0dp:8	M6X1.0dp:8	26	7

Type/Item	Stroke	P	LD	LE	M	PA	PB	PC	PD	Q	S	T	N															
													50	100	150	200	250	300	350	400	450	500	600	700	750	800		
RMH10	M5X0.8	3.5	10	1.5	4	7.5	11	2	18	10.5	14.5	2	3	4	5	6	7	-	-	-	-	-	-	-	-			
RMH16	M5X0.8	4.5	10	1.5	5.5	8.5	15	3.5	28	11	15	2	3	4	5	6	7	8	9	10	11	-	-	-	-			
RMH20	1/8"	5.5	12	1.5	0	10	18.5	0	37	8.5	12.5	2	3	4	5	6	7	8	9	10	11	13	15	16	17			
RMH25	1/8"	5.5	12	1.5	0	11	22	0	43.5	16	22	2	3	4	5	6	7	8	9	10	11	13	15	16	17			