



Tri-rod cylinder—TCL, TCM Series

Compendium of TCL/TCM Series

JIS standard

Two guides of special bearing steel
Steel ball linear bearing(TCL) or Brass sliding bearing(TCM)

Double-rod guide unit
Two guides of special bearing steel and linear bearing or brass bearing guide are used to prevent rotating. They can bear high torque and radial load.

Magnetic switch slots around the cylinder body
There are magnetic switch slots around the cylinder body convenient to install inducting switch.

Two groups of inlet and outlet air ports

Mounted from three directions

Multi-type cylinder

TCL: Linear bearing

TCM: Brass bearing

Twelve bore size are available
Bore size: 6, 10, 12, 16, 20, 25, 32, 40, 50, 63, 80, 100

Up inlet or outlet air port

Side inlet or outlet air port

Up mounted

Back mounted

Bottom mounted

Criteria for selection: Cylinder thrust

Unit : Newton(N)

Bore size	Rod size	Acting type	Pressure area(mm ²)	Operating pressure(MPa)						
				0.1	0.2	0.3	0.4	0.5	0.6	0.7
6	3	Double Push side	28.3	2.8	5.7	8.5	11.3	14.1	17.0	19.8
		Double Pull side	21.2	2.1	4.2	6.4	8.5	10.6	12.7	14.8
10	5	Double Push side	78.5	7.9	15.7	23.6	31.4	39.3	47.1	55.0
		Double Pull side	58.9	5.9	11.8	17.7	23.6	29.5	35.3	41.2
12	6	Double Push side	113.1	11.3	22.6	33.9	45.2	56.5	67.9	79.2
		Double Pull side	84.8	8.5	17.0	25.4	33.9	42.4	50.9	59.4
16	8	Double Push side	201.1	20.1	40.2	60.3	80.4	100.5	120.6	140.7
		Double Pull side	150.8	15.1	30.2	45.2	60.3	75.4	90.5	105.6
20	10	Double Push side	314.2	31.4	62.8	94.2	125.7	157.1	188.5	219.9
		Double Pull side	235.6	23.6	47.1	70.7	94.2	117.8	141.4	164.9
25	12	Double Push side	490.9	49.1	98.2	147.3	196.3	245.4	294.5	343.6
		Double Pull side	377.8	37.8	75.6	113.3	151.1	188.9	226.7	264.4
32	16	Double Push side	804.2	80.4	160.8	241.3	321.7	402.1	482.5	563.0
		Double Pull side	603.2	60.3	120.6	181.0	241.3	301.6	361.9	422.2
40	16	Double Push side	1256.6	125.7	251.3	377.0	502.7	628.3	754.0	879.6
		Double Pull side	1055.6	105.6	211.1	316.7	422.2	527.8	633.3	738.9
50	20	Double Push side	1963.5	196.3	392.7	589.0	785.4	981.7	1178.1	1374.4
		Double Pull side	1649.3	164.9	329.9	494.8	659.7	824.7	989.6	1154.5
63	20	Double Push side	3117.2	311.7	623.4	935.2	1246.9	1558.6	1870.3	2182.1
		Double Pull side	2803.1	280.3	560.6	840.9	1121.2	1401.5	1681.9	1962.2
80	25	Double Push side	5026.5	502.7	1005.3	1508.0	2010.6	2513.3	3015.9	3518.6
		Double Pull side	4535.7	453.6	907.1	1360.7	1814.3	2267.8	2721.4	3175.0
100	25	Double Push side	7854.0	785.4	1570.8	2356.2	3141.6	3927.0	4712.4	5497.8
		Double Pull side	7363.1	736.3	1472.6	2208.9	2945.2	3681.6	4417.9	5154.2

Installation and application



- When load changes in the work, the cylinder with abundant output capacity shall be selected.
- Relative cylinder with high temperature resistance or corrosion resistance shall be chosen under the condition of high temperature or corrosion.
- Necessary protection measure shall be taken in the environment with higher humidity, much dust or water drops, oil dust and welding dregs.
- Dirty substances in the pipe must be cleared away before cylinder is connected with pipeline to prevent the entrance of particles into the cylinder.
- The medium used by cylinder shall be filtered to 40μm or below.
- The cylinder shall avoid the influence of side load in operation to maintain the normal work of cylinder and extend the service life.
- Anti-freezing measure shall be adopted under low temperature environment to prevent moisture freezing.
- If the cylinder is dismantled and stored for a long time, please conduct anti-rust treatment to the surface. Anti-dust cap shall be inserted into the inlet and outlet ports. As the precision of the manufacture and guide is high, never dismantle the fixed block or cylinder cover without permission.



Tri-rod cylinder

TCL, TCM Series



Symbol

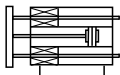

Product feature

- JIS standard is implemented.
- Two guides of special bearing steel and linear bearing or brass bearing guide are used to prevent rotating. They can bear high torque and radial load.
 - ★Note: Steel ball linear bearing: It is suitable for elevation action of cylinder or the situation requiring high precision and high bearing ability, especially for the situation requiring low friction action process.
 - Brass sliding bearing: it is suitable for the action that has radial load resistance. Compared with normal cylinder of same use, the horizontal impact resistance is doubled and it has stronger torsion rigidity.
- Drive unit and guide unit are in the same barrel that no additional accessories are needed with minimal space required. The air intake is optional and it is convenient to install.
- The bottom, back side and fixing plate of main body respectively has two exact orientation orifices (See ΦPA orifice and the orifice in XX point), which can provide orientation installation with high precision for the special situation.
- Options of switch mounting with provision 4 mounting slots.
- Special design of main body provides multi-mount;

How to mount

Fixation of screw on top surface($\Phi 6\sim\Phi 100$)

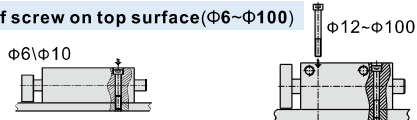

Fixation of screw at bottom surface($\Phi 12\sim\Phi 100$)

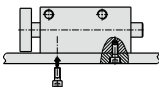

Fixation of T slot at bottom($\Phi 12\sim\Phi 100$)

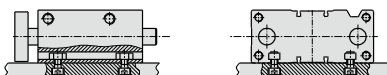

Specification

Bore size(mm)	6	10	12	16	20	25	32	40	50	63	80	100
Acting type	Double acting											
Fluid	Air(to be filtered by 40 μ m filter element)											
Operating pressure	0.2~0.7MPa(29~100psi)						0.15~1.0MPa(22~145psi)					
Proof pressure	1.2MPa(175psi)						1.5MPa(215psi)					
Temperature $^{\circ}C$	-20~70											
Speed range mm/s	50~500						30~500			50~400		
Stroke tolerance	$\leq 100 \begin{matrix} +1.0 \\ 0 \end{matrix}$						$> 100 \begin{matrix} +1.5 \\ 0 \end{matrix}$					
Cushion type	Bumper											
Non-rotating tolerance [Note1]	TCL	-	$\pm 0.08^{\circ}$	$\pm 0.07^{\circ}$	$\pm 0.06^{\circ}$	$\pm 0.05^{\circ}$	$\pm 0.05^{\circ}$	$\pm 0.05^{\circ}$	$\pm 0.05^{\circ}$	$\pm 0.05^{\circ}$	$\pm 0.05^{\circ}$	$\pm 0.05^{\circ}$
TCM	$\pm 0.1^{\circ}$	$\pm 0.10^{\circ}$	$\pm 0.09^{\circ}$	$\pm 0.08^{\circ}$	$\pm 0.08^{\circ}$	$\pm 0.06^{\circ}$	$\pm 0.05^{\circ}$	$\pm 0.05^{\circ}$	$\pm 0.05^{\circ}$	$\pm 0.05^{\circ}$	$\pm 0.05^{\circ}$	$\pm 0.05^{\circ}$
Port size [Note2]	M3 \times 0.5			M5 \times 0.8			1/8"		1/4"		3/8"	

[Note1] Retract position.

[Note2]PT thread, G thread and NPT thread are available.

Add) Refer to P362 for detail of sensor switch.

Stroke

Bore size (mm)	Standard stroke (mm)											Max.std stroke						
6	5	10	15	20									20					
10	5	10	15	20	25	30							30					
12	10	20	25	30	40	50	60	70	75	80	90	100	125	150	150			
16	10	20	25	30	40	50	60	70	75	80	90	100	125	150	175	200	200	
20 25	20	25	30	40	50	60	70	75	80	90	100	125	150	175	200	225	250	250
32 40 50 63	25	30	40	50	60	70	75	80	90	100	125	150	175	200	225	250	250	
80 100	25	30	40	50	60	70	75	80	90	100	125	150	175	200	225	250	250	

[Note] When the discrepancy between non-standard stroke and standard stroke is 1~5mm, The dimensions of non-std stroke cylinder has the same dimensions as the next longer stroke std. stroke cylinder. e.g. 86mm stroke cylinder has the same dimensions of 90 std. stroke cylinder. But 84mm stroke cylinder should be ordered by non-standard stroke.

Ordering code

TC M 50 \times 50 S □							
		①	②	③	④	⑤	⑥
① Model	② Bearing type	③ Bore size	④ Stroke	⑤ Magnet	⑥ Thread type [Note 2]		
TC: Tri-rod cylinder (Double acting type)	M: Brass bearing	6 10	Refer to stroke table for details	S: With magnet [Note1]	Blank: PT G: G T: NPT		
	L: Linear bearing	12 16 20 25 32					
	M: Brass bearing	40 50 63 80 100					

[Note1] TC Series are all with magnet. [Note2] When the thread is standard, the code is blank.

Fixation of screw at back side($\Phi 6\sim\Phi 100$)

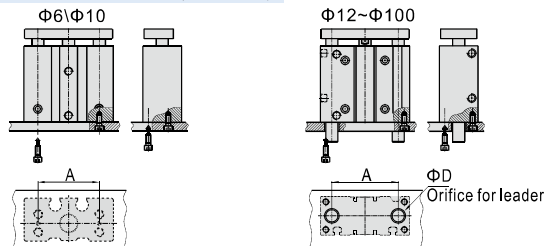

Bore size\Item	6	10	12	16	20	25	32	40	50	63	80	100
A	20.5	23	41	46	54	64	78	86	110	124	156	188
D	TCM	X	X	10	12	13	20	20	20	20	30	-
(Min)	TCL	-	-	8	10	10	13	20	20	20	-	30



Tri-rod cylinder

TCL, TCM Series

Safe load and torque

1. Max. safe load

TCM6,10 Max. safe load

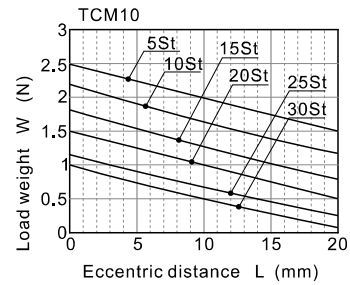
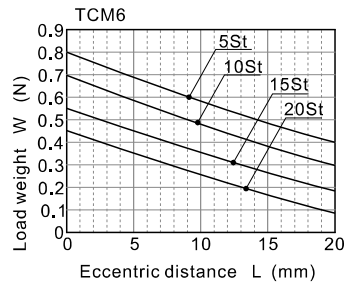
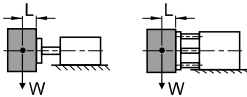

TC12~100 Max. safe load

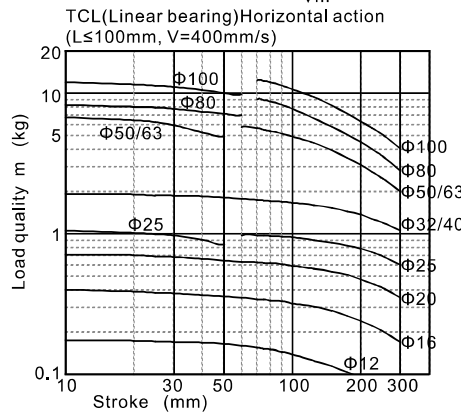
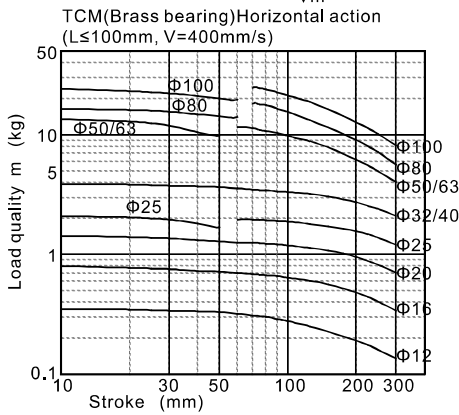

For other operating speeds of the cylinder, multiply the value of the graph when V=400mm/s by the coefficient in the following table, and the obtained value is the approximate value of the allowable load mass.

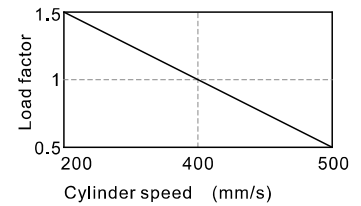

2. Max. safe torque

Max. safe torque

Unit: Newton·Meter(N·m)

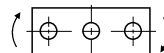

Bore size	Type	Stroke(mm)																			
		5	10	15	20	25	30	40	50	60	70	75	80	90	100	125	150	175	200	225	250
6	TCM	0.008	0.007	0.006	0.005	-	-	-	-	-	-	-	-	-	-	-	-	-	-	-	-
10	TCM	0.045	0.039	0.033	0.028	0.024	0.021	-	-	-	-	-	-	-	-	-	-	-	-	-	-
12	TCM	-	0.39	-	0.32	0.29	0.27	0.24	0.21	0.49	0.46	0.43	0.42	0.39	0.36	0.31	0.27	-	-	-	-
	TCL	-	0.35	-	0.29	0.26	0.24	0.22	0.19	0.44	0.39	0.37	0.35	0.32	0.29	0.24	0.20	-	-	-	-
16	TCM	-	0.69	-	0.58	0.54	0.49	0.43	0.38	0.75	0.72	0.69	0.65	0.61	0.58	0.50	0.44	0.40	0.36	-	-
	TCL	-	0.62	-	0.52	0.49	0.44	0.39	0.34	0.68	0.65	0.62	0.59	0.55	0.52	0.43	0.37	0.32	0.28	-	-
20	TCM	-	-	-	1.05	0.99	0.93	0.83	0.75	1.97	1.90	1.88	1.86	1.72	1.63	1.44	1.28	1.16	1.06	1.01	0.90
	TCL	-	-	-	0.95	0.89	0.84	0.75	0.68	1.77	1.59	1.52	1.46	1.33	1.25	1.30	1.15	1.03	0.93	0.88	0.76
25	TCM	-	-	-	1.76	1.65	1.55	1.38	1.25	3.17	3.06	2.96	2.91	2.77	2.57	2.26	2.02	1.83	1.67	1.57	1.42
	TCL	-	-	-	1.58	1.49	1.40	1.24	1.13	2.71	2.42	2.38	2.33	2.19	1.97	2.03	1.78	1.58	1.41	1.22	1.16
32	TCM	-	-	-	-	6.35	6.00	5.73	5.13	5.98	5.74	5.69	5.62	5.11	4.97	4.42	3.98	3.61	3.31	2.97	2.84
	TCL	-	-	-	-	5.72	5.40	5.16	4.62	5.38	5.15	5.11	5.02	4.60	4.47	3.98	3.58	3.25	2.98	2.67	2.56
40	TCM	-	-	-	-	7.00	6.60	6.11	5.66	6.66	6.31	6.27	6.23	5.86	5.48	4.78	4.38	3.98	3.65	3.34	3.13
	TCL	-	-	-	-	6.30	5.94	5.50	5.09	5.99	5.67	5.62	5.58	5.27	4.93	4.30	3.94	3.58	3.29	3.01	2.82
50	TCM	-	-	-	-	13.00	12.60	11.00	10.80	13.70	12.70	12.00	11.80	11.10	10.60	9.50	8.60	7.86	7.24	6.80	6.24
	TCL	-	-	-	-	9.17	8.75	8.30	7.62	10.30	9.94	9.83	9.77	8.82	8.74	8.55	7.74	7.07	6.52	6.12	5.62
63	TCM	-	-	-	-	14.70	13.60	12.90	12.10	19.40	16.20	13.50	12.70	12.10	11.90	10.70	9.69	8.86	8.16	7.52	7.04
	TCL	-	-	-	-	10.20	9.74	9.20	8.48	17.46	14.00	11.00	10.60	10.20	9.74	9.63	8.72	7.97	7.34	6.77	6.34
80	TCM	-	-	-	-	21.90	20.80	19.70	18.60	15.80	24.00	22.90	21.70	21.00	20.50	18.60	17.00	15.60	14.50	13.50	12.60
	TCL	-	-	-	-	15.10	14.30	13.60	12.90	12.20	21.60	20.61	19.53	18.90	18.45	16.74	15.30	14.04	13.05	12.15	11.34
100	TCM	-	-	-	-	38.80	36.80	35.00	33.50	28.50	39.40	37.50	35.60	34.50	33.80	30.90	28.40	26.20	24.40	22.50	21.40
	TCL	-	-	-	-	27.10	25.70	24.40	30.15	25.65	35.46	33.75	32.04	31.05	30.42	27.81	25.56	23.58	21.96	20.25	19.26

Tri-rod cylinder

TCL, TCM Series



Inner structure and material of major parts

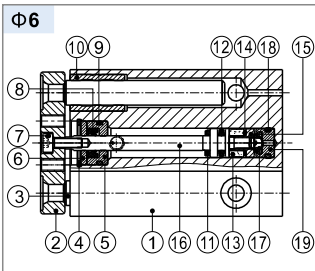

NO.	Item	Material
1	Body	Aluminum alloy
2	Fixing plate	Carbon steel
3	Guide rod	Stainless steel
4	C clip	Spring steel
5	Front cover	Aluminum alloy
6	O-ring stop block	Aluminum alloy
7	Screw	Alloy steel
8	Piston rod O-ring	NBR
9	O-ring	NBR
10	Bearing	Brass
11	Bumper	TPU
12	Piston seal	NBR
13	Magnet	Rare Earth
14	Magnet washer	NBR
15	Piston	Stainless steel
16	Piston rod	Stainless steel
17	Bumper	TPU
18	O-ring	NBR
19	Washer	Aluminum alloy

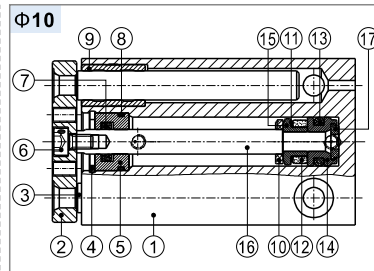

NO.	Item	Material
1	Body	Aluminum alloy
2	Fixing plate	Carbon steel
3	Guide rod	Stainless steel
4	C clip	Spring steel
5	Front cover	Aluminum alloy
6	Screw	Alloy steel
7	Piston rod O-ring	NBR
8	O-ring	NBR
9	Bearing	Brass
10	Bumper	TPU
11	Magnet washer	NBR
12	Magnet	Rare Earth
13	Piston seal	NBR
14	Piston	Brass
15	Magnet holder	Brass
16	Piston rod	Stainless steel
17	Bumper	TPU

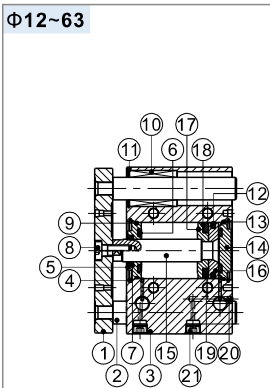

TCL	TCL
<p>Bore size Φ12, Φ16mm Stroke ≤ 30mm</p>	<p>Bore size Φ20~Φ63mm Stroke ≤ 50mm</p>
<p>Bore size Φ12, Φ16mm 30 < Stroke ≤ 100mm</p>	<p>Bore size Φ20~Φ63mm 50 < Stroke ≤ 100mm</p>
<p>Bore size Φ12, Φ16mm Stroke > 100mm</p>	<p>Bore size Φ20~Φ63mm Stroke > 100mm</p>

TCM	TCM	TCM
<p>Bore size Φ12~Φ25mm Stroke ≤ 50mm</p>	<p>Bore size Φ12~Φ63mm 50 < Stroke ≤ 100mm</p>	<p>Bore size Φ12~Φ63mm Stroke > 100mm</p>

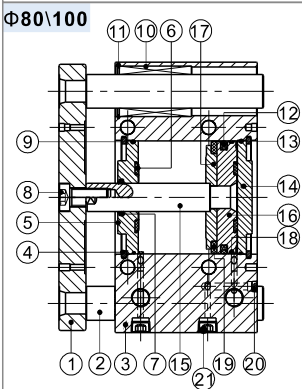

TCL	TCL	TCL
<p>Stroke S=25~60mm</p>	<p>Stroke S=70~150mm</p>	<p>Stroke S=175~250mm</p>

TCM
<p>Stroke S=25~250mm</p>

NO.	Item	Material
1	Fixing plate	Carbon steel
2	Leader	Carbon steel
3	Body	Aluminum alloy
4	C clip	Spring steel
5	Front cover	Aluminum alloy
6	Bumper	TPU
7	Piston rod O-ring	NBR
8	Screw	Alloy steel
9	O-ring	NBR
10	Bearing	Bearing steel/brass
11	C clip	Spring steel
12	Piston seal	NBR
13	O-ring	NBR
14	Back cover	Brass/aluminum alloy
15	Piston rod	Carbon steel
16	Piston	Brass/aluminum alloy
17	Magnet holder	Brass/aluminum alloy
18	Magnet washer	NBR
19	Magnet	Rare Earth/Plastic
20	Screw	Alloy steel
21	Screw	Alloy steel
22	Spacer	Aluminum alloy



Tri-rod cylinder

TCL, TCM Series

Dimensions

TCM6/TCM10

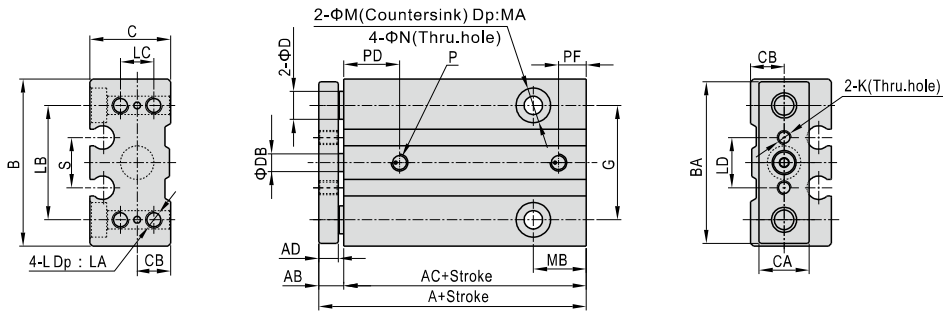

Bore size/Item	A	AB	AC	AD	B	BA	C	CA	CB	D	DB	G	K	L	LA	LB	LC	LD	M	MA	MB	N	P	PD	PF
6	29.5	6	23.5	5	30	29	14.5	9	6	5	3	20.5	M2.5X0.45	M3X0.5	5	20.5	6	9	6	3	9.5	3.5	M3X0.5	9.5	5.5
10	32	6	26	5	34	33	18	10	7.5	6	5	23	M3X0.5	M4X0.7	5	23	8	11	8	4	8.5	4.5	M3X0.5	11.5	5

TCL/TCM12~63

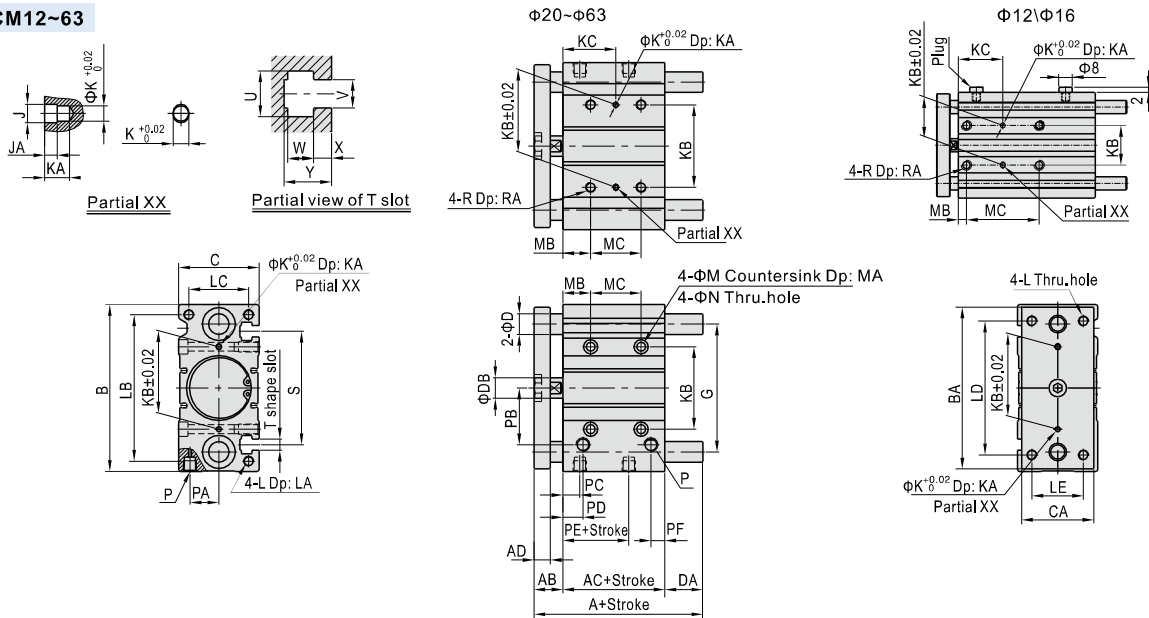

Bore size/Item	A					DA				MC				KC							
	TCL	TCM	TCL/TCM	TCL	TCM	TCL	TCM	TCL	TCM	TCL	TCM	TCL	TCM	TCL	TCM	TCL	TCM				
Stroke	≤30	≤50	31(51)~100	101~200	>200	≤30	31~100	101~200	>200	≤50	51~100	101~200	>200	≤40	41~100	101~200	>200	≤40	41~100	101~200	>200
12	42	55	85	-	0	13	43	-	0	13	43	-	20	40	110	-	15	25	60	-	
16	46	65	95	-	0	19	49	-	0	19	49	-	24	44	110	-	17	27	60	-	
20	53	80	104	122	0	27	51	69	0	27	51	69	24	44	120	200	29	39	77	117	
25	53.5	82	104.5	122	0	28.5	51	68.5	0	28.5	51	68.5	24	44	120	200	29	39	77	117	
Stroke	≤50	≤50	51~100	101~200	>200	≤50	51~100	101~200	>200	≤50	51~100	101~200	>200	≤40	41~100	101~200	>200	≤40	41~100	101~200	>200
32	65	78	102	118	140	5.5	42.5	58.5	80.5	18.5	42.5	58.5	80.5	24	48	124	200	33	45	83	121
40	66	78	102	118	140	0	36	52	74	12	36	52	74	24	48	124	200	34	46	84	122
50	76	89	118	134	161	4	46	62	89	17	46	62	89	24	48	124	200	36	48	86	124
63	77	89	118	134	161	0	41	57	84	12	41	57	84	28	52	128	200	38	50	88	124
Bore size/Item	AB	AC	AD	B	BA	C	CA	D(TCL)	D(TCM)	DB	G	J	JA	K	KA	KB	L	LA	LB	LC	LD
12	13	29	8	58	56	26	22	6	8	6	41	3.5	3	3	6	23	M4×0.7	10	50	18	48
16	13	33	8	64	62	30	25	8	10	6	46	3.5	3	3	6	24	M5×0.8	12	56	22	54
20	16	37	10	83	81	36	30	10	12	10	54	3.5	3	3	6	28	M5×0.8	13	72	24	70
25	16	37.5	10	93	91	42	38	12	16	12	64	4.5	3	4	6	34	M6×1.0	15	82	30	78
32	22	37.5	12	112	110	48	44	16	20	16	78	4.5	3	4	6	42	M8×1.25	20	98	34	96
40	22	44	12	120	118	54	44	16	20	16	86	4.5	3	4	6	50	M8×1.25	20	106	40	104
50	28	44	16	148	146	64	60	20	20	20	110	6	4	5	8	66	M10×1.5	22	130	46	130
63	28	49	16	162	158	78	70	20	20	20	124	6	4	5	8	80	M10×1.5	22	142	58	130
Bore size/Item	LE	M	MA	MB	N	P	PA	PB	PC	PD	PE	PF	R	RA	S	U	V	W	X	Y	
12	14	8	4.5	5	4.5	M5×0.8	8	18	11	11	13	7.5	M5×0.8	12	37	7.5	4.5	4	2	6.5	
16	16	8	4.5	5	4.5	M5×0.8	10	19	11	11	15	8	M5×0.8	10	38	7.5	4.5	4	2.5	7	
20	18	9.5	5.5	17	5.5	1/8"	11	25	10.5	10.5	12.5	9	M6×1.0	12	44	8.5	5.5	4.5	3	8	
25	26	9.5	5.5	17	5.5	1/8"	13.5	28.5	11.5	11.5	12.5	9	M6×1.0	12	50	8.5	5.5	4.5	3	8.5	
30	30	11	7.5	21	6.5	1/8"	16	34	12.5	12.5	7	9	M8×1.25	16	63	10.5	6.5	5.5	3.5	9.5	
40	30	11	7.5	22	6.5	1/8"	18	38	14	14	13	10	M8×1.25	16	72	10.5	6.5	5.5	4	11	
50	40	14	9	24	8.5	1/4"	21.5	47	12	14	9	11	M10×1.5	20	92	13.5	8.5	7.5	4.5	13.5	
63	50	14	9	24	8.5	1/4"	28	55	16.5	16.5	14	13.5	M10×1.5	20	110	18	11	10	7	18.5	



Tri-rod cylinder

TCL, TCM Series

TCL/TCM80

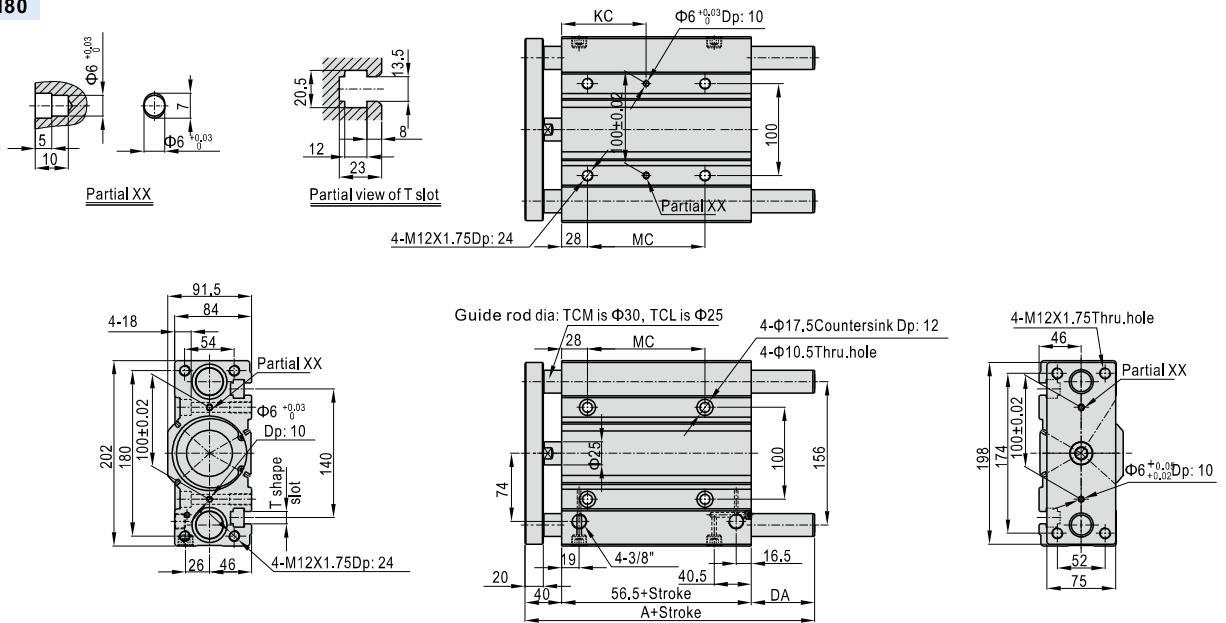

Item\Stroke	25	30	40	50	60	70	75	80	100	125	150	175	200	225	250
A	TCM=112.5/TCL=106.5					165.5					187.5				
DA	TCM=16/TCL=10					69					91				
KC	42					54					92				
MC	28					52					128				

TCL/TCM100

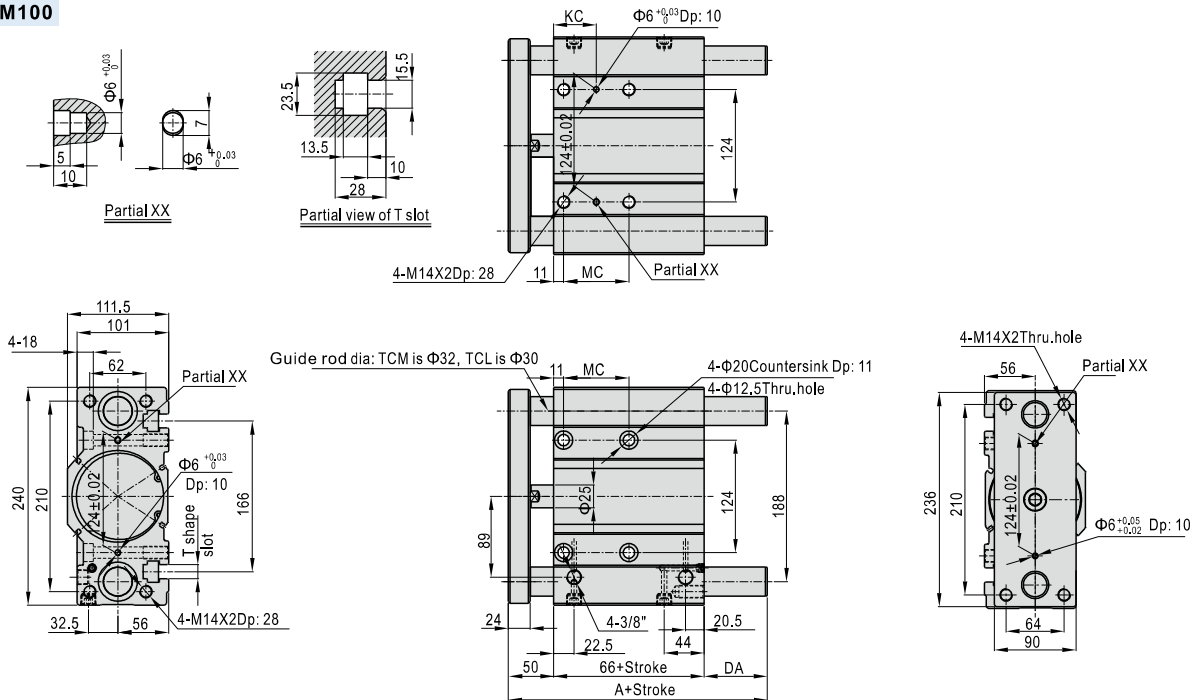

Item\Stroke	25	30	40	50	60	70	75	80	100	125	150	175	200	225	250
A	TCM=128/TCL=122					186					208				
DA	TCM=12/TCL=6					70					92				
KC	35					47					85				
MC	48					72					148				