

# Cylinder joint accessory

## Universal Joint



Table for universal joint and cylinder

Cylinder Accessory	SE						SAI					SAI/SC				
	32	40	50	63	80	100	125	32	40	50	63	80	100	125	160	200
F-M10X125U	•							•								
F-M12X125U		•							•							
F-M16X150U			•	•						•	•					
F-M20X150U					•	•						•	•			
F-M27X200U							•							•		
F-M36X200U															•	•

Cylinder Accessory	SGC				SC/SAU				JSI								
	125	160	200	250	32	40	50	63	80	100	32	40	50	63	80	100	125
F-M10X125U					•							•					
F-M12X125U						•											
F-M14X150U													•				
F-M16X150U							•	•									
F-M18X150U													•	•			
F-M20X150U									•	•							
F-M26X150U																•	
F-M27X200U	•																•
F-M36X200U		•	•														

Cylinder Accessory	ACQ									
	12	16	20	25	32	40	50	63	80	100
F-M5X080U	•									
F-M6X100U		•								
F-M8X125U			•							
F-M10X125U				•						
F-M12X125U					•	•				
F-M14X150U						•	•			
F-M16X150U										
F-M18X150U							•	•		
F-M20X150U										
F-M26X150U										•

Cylinder Accessory	MA				MF				MBL								
	16	20	25	32	40	50	63	20	25	32	40	20	25	32	40	50	63
F-M6X100U	•																
F-M8X125U		•						•					•				
F-M10X125U			•	•					•	•			•	•			
F-M12X125U					•										•		
F-M14X150U						•	•				•					•	•

Cylinder Accessory	PB				MI								
	4	6	10	12	16	8	10	12	16	20	25	32	40
F-M4X070U			•				•	•					
F-M5X080U				•	•								
F-M6X100U								•	•				
F-M8X125U										•			
F-M10X125U											•	•	
F-M12X125U													•

## Ordering code

**F-M10 X125 U**

① ② ③ ④

① Accessories code	② Screw thread	③ Thread pitch	④ Code
	M4 : M4	070 : 0.7mm	U: Universal joint
	M5 : M5	080 : 0.8mm	
	M6 : M6	100 : 1.0mm	
	M8 : M8	125 : 1.25mm	
	M10 : M10		
	M12 : M12		
	M14 : M14		
	M16 : M16	150 : 1.5mm	
	M18 : M18		
	M20 : M20		
	M26 : M26		
	M27 : M27	200 : 2.0mm	
	M36 : M36		

## Dimensions

### M8 and below

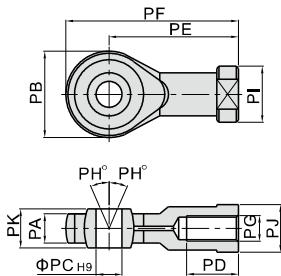

### M10 and above

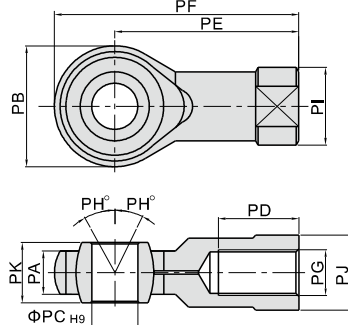

Type/Item	PA	PB	PC	PD	PE	PF	PG	PH	PH'	PJ	PK
F-M4X070U	6	18	5	10	27	36	M4×0.7	13	12.5	10	8
F-M5X080U	6	18	5	10	27	36	M5×0.8	13	12.5	10	8
F-M6X100U	6.8	20	6	12	30	40	M6×1.0	13	13	11	9
F-M8X125U	9	24	8	16	36	48	M8×1.25	13	16	14	12
F-M10X125U	11	26	10	20	43	56	M10×1.25	13	19	17	14
F-M12X125U	12	32	12	22	50	66	M12×1.25	13	22	19	16
F-M14X150U	14	36	14	28	57	75	M14×1.5	13	25	22	19
F-M16X150U	15	40	16	28	64	84	M16×1.5	15	27	22	21
F-M18X150U	16.5	46	18	30	71	94	M18×1.5	15	31	27	23
F-M20X150U	18	46	20	33	77	100	M20×1.5	15	34	30	25
F-M26X150U	22	60	25	48	94	124	M26×1.5	15	42	36	31
F-M27X200U	25	70	30	51	110	145	M27×2.0	15	50	41	37
F-M36X200U	27.5	80	35	56	125	165	M36×2.0	15	57.5	50	43