

Angle seat valve(2/2 way)

2J Series

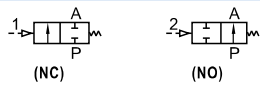

Symbol



Product feature

- Air piloted and can be used non electric, inflammable and explosive environment. The start-up pressure is low; and the high pressure could be controlled by the low pressure.
- The accessories such as the noumenon and slide bar are made of stainless steel, which are of excellent rustproof quality. The seals are made of Teflon and can be applied extensively in areas with high temperature and strong corrosive liquids.
- The structure of valve is angles at 45° degrees with streamline inner chamber design. The reduced tunnel resistance allows liquid to run more smoothly thus achieving high flow. Filtration core are added at inlet port to prevent the entrance of impurities and extend life span of the seals.
- Actuator is fitted with visual position indicator. This allows for visual checking and adjustment of flowrate.
- Control point is made of metal insert. Mounting plate can be used to for NAMUR value.
- The actuator part can be rotated at 360° degrees and is easily installed.

Ordering code

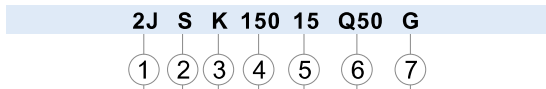

① Model	② Valve body material	③ Acting type	④ Orifice size	⑤ Port size	⑥ Size of actuator	⑦ Thread type
2J: Angle seat valve(2/2 way)	S: SUS316L W: SUS304	Blank: No water-hammer(NC) Control pressure → The working medium flows to the down side of valve inlet (Flow from the bottom part to upper part of piston) Work pressure →	150: Φ15mm	10: 3/8" 15: 1/2"	Q40: Φ40mm Q50: Φ50mm Q63: Φ63mm Q80: Φ80mm	G: G T: NPT
		Y: Water-hammer(NC) Control pressure → The working medium flows to the upper side of valve inlet (Flow from the upper part to bottom part of piston) Work pressure →	200: Φ20mm	20: 3/4"		
		K: Normal opened Control pressure → The working medium flows to the down side of valve inlet (Flow from the bottom part to upper part of piston) Work pressure →	250: Φ25mm	25: 1"		
		Control pressure → The working medium flows to the down side of valve inlet (Flow from the bottom part to upper part of piston) Work pressure →	320: Φ32mm	32: 1 1/4"		

Specification

Model/Item	Port	Actuator size(mm)	Orifice size(mm)	Kv	Min.pilot pressure(bar)	Max.differential pressure(bar)	Weight (kg)	
2JS150 2JW150	-10 G3/8	40	15	4.4	4.8	13	0.8	
	-15 G1/2						0.7	
2JS200 2JW200	-10 G3/8	50	20	4.8	4.3	16	0.8	
	-15 G1/2						0.7	
2JS250 2JW250	-25 G1	40	25	7.9	4.2	11	0.9	
		50		8			11	0.95
		63		10			16	1.6
2JS320 2JW320	-32 G1 1/4	63	32	19	5.0	16	1.9	
		80		20			16	2.5
2JSK150 2JWK150	-10 G3/8	40	15	4.4	4.8	16	0.8	
	-15 G1/2						0.7	
2JSK200 2JWK200	-10 G3/8	50	20	4.8	4.3	16	0.8	
	-15 G1/2						0.7	
2JSK250 2JWK250	-25 G1	40	25	7.9	5.0	16	0.9	
		50		8			16	0.9
2JSK320 2JWK320	-32 G1 1/4	50	32	14.5	5.0	16	1.2	
		63		19			16	1.6
2JSY150 2JWY150	-10 G3/8	40	15	4.4	4.8	16	0.8	
	-15 G1/2						0.7	
2JSY200 2JWY200	-10 G3/8	50	20	4.8	4.3	16	0.8	
	-15 G1/2						0.7	
2JSY250 2JWY250	-25 G1	40	25	7.9	5.0	16	0.9	
		50		8			16	0.9
2JSY320 2JWY320	-32 G1 1/4	50	32	14.5	5.0	16	1.3	
		63		19			16	1.7

Angle seat valve(2/2 way)

2J Series

Inner structure

2JS150-Q50

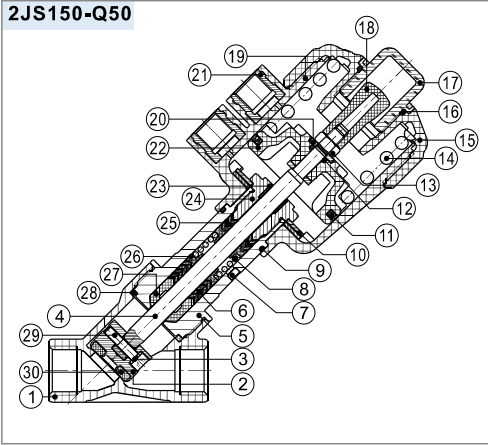

No.	Item	Material	No.	Item	Material
1	Body	Stainless steel	16	O-ring	NBR
2	Piston	Stainless steel	17	Transparent cap	Plastic
3	Spring washer	Spring steel	18	Indicate rod	Plastic
4	Piston rod	Stainless steel	19	Cylinder body	PA6
5	Pitman	Stainless steel	20	Washer	SPCC
6	V-seals	PTFE	21	Built-in nut	Brass nickel-plate
7	Filter core	Bronze	22	Piston	PA6
8	Spring	Spring steel	23	DU dry bearing	Wear resistant material
9	O-ring	NBR	24	Connect nut	Brass
10	Bellville spring	Spring steel	25	O-ring	Viton
11	O-ring	NBR	26	Spring holder	PTFE
12	O-ring	NBR	27	Guide sleeve	PTFE
13	Hexagon nut	Steel	28	Seal washer	PTFE
14	Spring	Spring steel	29	Screw	Stainless steel
15	Top cover	PA6	30	Seal washer	PTFE

Dimensions

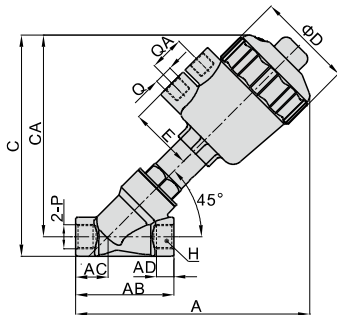

Orifice size(DN)	Size of actuator	A	AB	AC	AD	C	CA	ΦD	E	H	Port size(P)	Q	QA
15	Φ40	153	68	22.5	12	144	130	56	33	27	G3/8	G1/8	
	Φ50	162				153	140	66	44		G1/2	G1/4	
20	Φ40	161	78	27	14	150	134	56	33	33	G3/4	G1/8	24
	Φ50	170				160	143	66	44			G1/4	
	Φ63	200				189	172	82	51			G1/4	
	Φ50	176				168	147	66	44			G1/4	
25	Φ63	205	90	28	18	197	176	82	51	40	G1	G1/4	
	Φ80	221				213	193	102	60			G1/4	
	Φ63	220				210	185	82	51			G1 1/4	
Φ80	237	227	202	102	60	G1/4							

Fluid pressure — control pressure curve

Normal opened

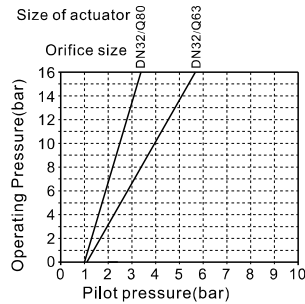
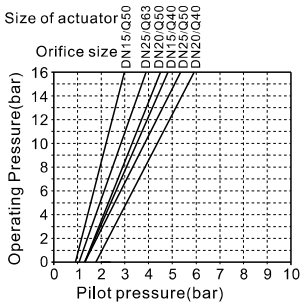
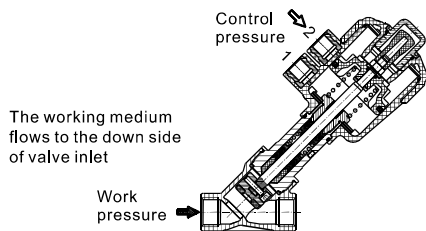

Water-hammer(NC)

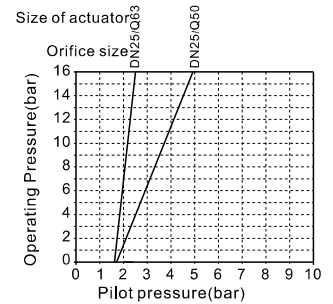
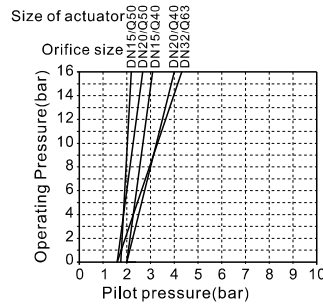
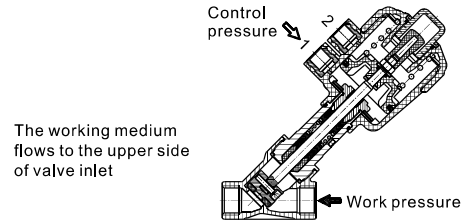

Angle seat valve(2/2 way)

2J Series

Ambient and medium temperature

Control medium	Air, neutral air(to be filtered by 40µm filter element)
Max. control pressure	Size of actuatorΦ40/50/63 : 10bar
	Size of actuatorΦ80 : 7bar
Medium [Note1]	air, liquid, steam
Viscosity limit	600mm ² /s below
Temperature [Note2]	-20~+180°C
Ambient temp [Note3]	-10~+60°C

[Note1]: The water-hammer-type can be used for air only, and can not be used for liquid.

Note 2): Dew point: -20°C or less.

[Note3): Relationship of working medium temperature and ambient temperature is shown in following figure.

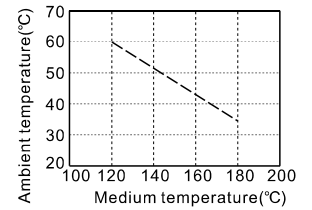

Operation and maintenance

1. Before using, please verify that if the working status of product is identical with data in catalogue, and it should not exceed the limits.
2. Before the pressure releasing and cooling of system, no maintenance, examination and installation of product should be conducted.
3. For the normally-closed-type, when its valve is disassembled, due to the pre-pressure of the relatively large spring power in controller, the "1" hole should be opened for ventilation in advance so to make sure the piston could be completely moved to the position, then rotate the screw thread between the valve and the connection bar, direct rotation is forbidden, otherwise the disassembling would not be conducted in result of the scuffing of screw thread.
4. If maintenance of actuator part is needed, special tools should be used for disassembling and installation, while disassembling, the loading spring could cause damage. If the customer can not conduct the maintenance, please return the valve to manufacturer for maintenance.

