

Fluid control valve(2/2way)

2WA Series (Direct-acting and normally closed)



Symbol



Product feature

1. Direct acting and normally closed type 2/2 way fluid valve. Its high sensibility allows it to change direction quickly;
2. It has wide pressure range, including extra high pressure (X), high pressure (H), standard , large volume(L) and extra large volume (T);
3. It is compact, small size and light weight. Easy to install and dismantle.
4. The valve body is made of brass . Its coil has a Heat resistance classification of Class F. The standard seal material is FPM-F. Please contact us if other seal material are required.
5. The protection class of the coil is IP65 and there is a choice for grommet or terminal electrical entry .

Inner structure

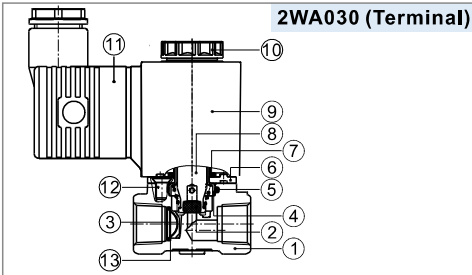

No.	Item	No.	Item
1	Body	8	Movable core
2	Airtight ring	9	Coil assembly
3	Spring	10	Coil nut
4	Steel bushing	11	Connector
5	O-ring	12	Screw
6	Fixed plate	13	Filter [Note]
7	O-ring		

[Note] Extra large volume type has no filter element.

Ordering code

Ordering code of valves

2WA L 030 08 A □ □



① Model	② Pressure condition	③ Size series	④ Port size	⑤ Voltage	⑥ Electrical entry	⑦ Thread type
2WA: 2/2 way direct-acting and normally closed	X: Extra high pressure H: High pressure Blank: Standard L: Large volume T: Extra large volume	030: 030 Series 050: 050 Series	06: 1/8" 08: 1/4" 10: 3/8" 15: 1/2"	A: AC220V B: DC24V C: AC110V E: AC24V F: DC12V	Blank: Terminal I: Grommet[Note]	Blank: PT G: G T: NPT

[Note] The wire length is 0.5m.

Ordering code of accessories

F-2WA030 LB



① Accessories code	② Valve type	③ Accessories type
F: Mounting accessories	2WA030: 030 Series valve 2WA050: 050 Series valve	LB: LB Type

Specification

Model\Item	Port size [Note1]	Orifice size (Φmm)	Cv	Valid area or section (mm ²)	Weight [Note2](g)	Max.operating pressure differential		Proof pressure	
						MPa	psi	MPa	psi
2WAX030	-06	1/8"	1.5	0.10	1.8	3.0	450	5.0	750
	-08	1/4"							
2WAH030	-06	1/8"	2.0	0.18	3.0	2.0	300		
	-08	1/4"							
2WA030	-06	1/8"	3.0	0.33	6.0	1.0	150		
	-08	1/4"							
2WAL030	-06	1/8"	4.0	0.55	10.0	0.5	75		
	-08	1/4"							
2WAT030	-06	1/8"	6.0	1.10	12.0	0.1	15		
	-08	1/4"							
2WAX050	-10	3/8"	3.0	0.34	6.1	3.0	450		
	-15	1/2"							
2WAH050	-10	3/8"	4.0	0.55	10.0	2.0	300		
	-15	1/2"							
2WA050	-10	3/8"	5.0	0.83	15.0	1.0	150		
	-15	1/2"							
2WAL050	-10	3/8"	7.0	1.40	25.0	0.5	75		
	-15	1/2"							
2WAT050	-10	3/8"	10.0	2.20	40.0	0.1	15		
	-15	1/2"							

[Note1] PT thread, G thread, and NPT thread are available.

[Note2] The weight in the table is the terminal valve's weight, 2WA030 series grommet valve's weight is 10g less than terminal's, 2WA050series grommet valve's weight is 20g less than terminal's.

Specification of coil

Valve type	Coil type	Power type	Frequency (Hz)	Voltage range	Electrical entry	Power Consumption (VA/W)	Insulation	Temp. rise(°C)
2WA□030	CDA110 CLA110	AC	50	± 15%	Terminal (CDA)	10.0VA	Class F	50
			60			8.0VA		45
		DC	-	± 10%		6.5W		50
2WA□050	CDA160 CLA160	AC	50	± 15%	Grommet (CLA)	25.0VA	Class F	65
			60			22.0VA		60
		DC	-	± 10%		12.0W		50

Valve's specification

Acting		Direct acting			
Initial state		Normally closed			
Adaptable fluid		Air, Water, Oil			
Viscosity limit		Under 20CST			
Ambient and fluid temperature (°C)		Water	Air	Oil	Ambient
	Max.	80	90	80	70
	Min.	1	-20 [Note1]	-10 [Note2]	-20

[Note1] Dew point: -20(°C) or less ;

[Note2] 50CST or less.



Fluid control valve(2/2way)

2WA Series (Direct-acting and normally closed)



Flow chart

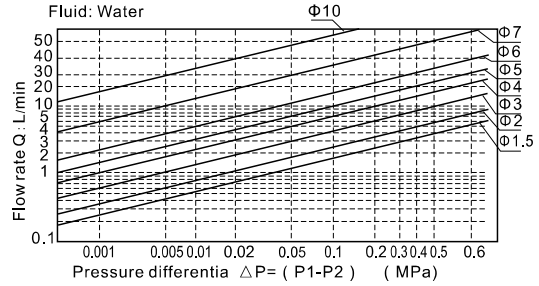
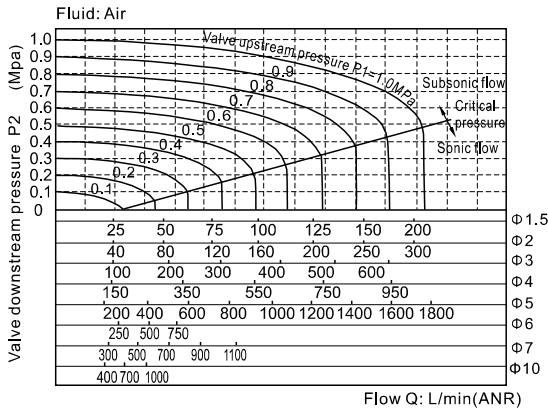

Dimensions

2WA□030 (Terminal)

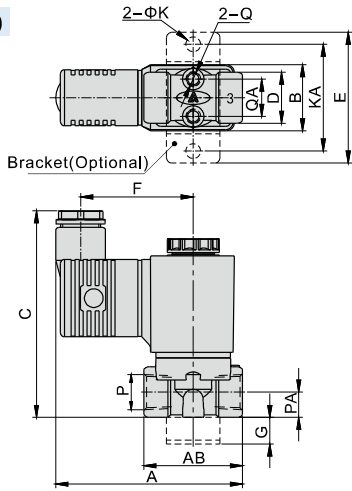

2WA□030 (Grommet)

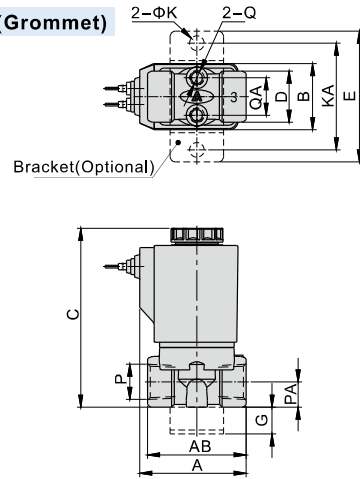

2WA□050 (Terminal)

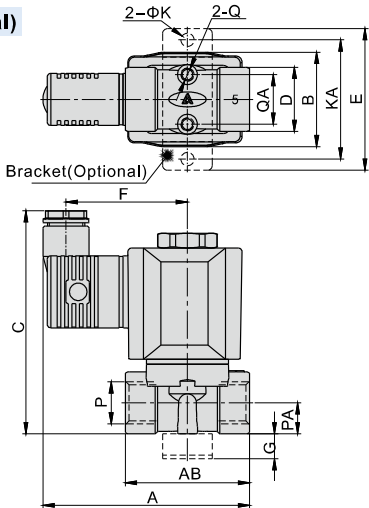

2WA□050 (Grommet)

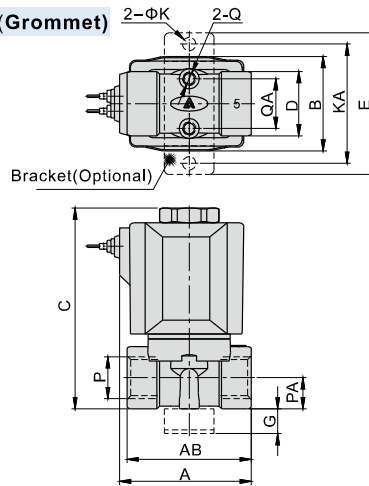

Model/Item	A	AB	B	C	D	E	F	G	K	KA	P	PA	Q	QA
2WA□030-06	70	37	25	77.5	19	49	42	10	5.5	40	1/8"	9.5	M5	13.5
2WAT□030-06	71.5	39.5	25	77.5	19	49	42	10	5.5	40	1/8"	9.5	M5	13.5
2WA□030-08	70	37	25	77.5	19	49	42	10	5.5	40	1/4"	9.5	M5	13.5
2WAT□030-08	71.5	39.5	25	77.5	19	49	42	10	5.5	40	1/4"	9.5	M5	13.5
2WA□050-10	83	50	38	90	26	57	49	10	5.5	48	3/8"	12.5	M5	19.5
2WAT□050-10	84	51	38	93	26	57	49	10	5.5	48	3/8"	12.5	M5	19.5
2WA□050-15	83	50	38	90	26	57	49	10	5.5	48	1/2"	12.5	M5	19.5
2WAT□050-15	84	51	38	93	26	57	49	10	5.5	48	1/2"	12.5	M5	19.5

Model/Item	A	AB	B	C	D	E	G	K	KA	P	PA	Q	QA
2WA□030-06	40	37	25	67	19	49	10	5.5	40	1/8"	9.5	M5	13.5
2WAT□030-06	41.5	39.5	25	67	19	49	10	5.5	40	1/8"	9.5	M5	13.5
2WA□030-08	40	37	25	67	19	49	10	5.5	40	1/4"	9.5	M5	13.5
2WAT□030-08	41.5	39.5	25	67	19	49	10	5.5	40	1/4"	9.5	M5	13.5
2WA□050-10	53	50	38	81	26	57	10	5.5	48	3/8"	12.5	M5	19.5
2WAT□050-10	54	51	38	84	26	57	10	5.5	48	3/8"	12.5	M5	19.5
2WA□050-15	53	50	38	81	26	57	10	5.5	48	1/2"	12.5	M5	19.5
2WAT□050-15	54	51	38	84	26	57	10	5.5	48	1/2"	12.5	M5	19.5



Fluid control valve(2/2way)

2WA Series (Internally piloted and normally closed)



Symbol



Product feature

1. Indirect acting (Internal pilot) and normally closed type 2/2 way fluid valve. It can change direction quickly and has large flow.
2. It is compact, small and light weight, Easy to install and dismantle;
3. The valve body is made of brass. The coil has a Heat resistance classification of Class F. The standard seal material is FPM-F, Please contact us if other seal material are required.
4. The protection class of the coil is IP65 and there is a choice for grommet or terminal electrical entry.

Inner structure

2WA150 (Grommet)

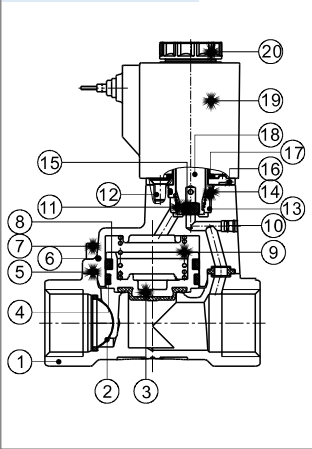

No.	Item
1	Body
2	Filter
3	Piston
4	Wear ring
5	O-ring
6	Cover
7	Screw
8	Spring
9	Spring
10	Spacer
11	Spring
12	Screw
13	Steel bushing
14	O-ring
15	Airtight ring
16	Fixed plate
17	O-ring
18	Movable core
19	Coil assembly
20	Coil nut

Specification

Model\Item	Port size [Note1]	Orifice size (Φmm)	Cv	Valid area or section (mm ²)	Weight [Note2](g)	Operating pressure differential		Proof pressure	
						MPa	psi	MPa	psi
2WA150-15	1/2"	15.0	5.50	100.0	575	Max: 1.0 Min: 0.05	Max: 150 Min: 10	1.5	220
2WA200-20	3/4"	20.0	9.50	170.0	735				
2WA250-25	1"	25.0	12.5	220.0	1035				

[Note1] PT thread, G thread and NPT thread are available.

[Note2] The weight in the table is the terminal valve's weight, grommet valve's weight is 10g less than terminal's.

Specification of coil

Valve type	Coil type	Power type	Frequency (Hz)	Voltage range	Electrical entry	Power Consumption (VA/W)	Insulation	Temp. rise(°C)
2WA150	CDA110	AC	50	±15%	Terminal (CDA)	10.0VA	Class F	50
2WA200	CLA110	DC	60			8.0VA		45
2WA250		DC	-	±10%	6.5W	50		

Valve's specification

Acting	Internally piloted				
	Initial state	Normally closed			
Adaptable fluid	Air, Water, Oil				
Viscosity limit	Under 20CST				
Ambient and fluid temperature (°C)		Water	Air	Oil	Ambient
	Max.	80	90	80	70
	Min.	1	-20 [Note1]	-10 [Note2]	-20

[Note1] Dew point: -20(°C) or less ; [Note2] 50CST or less.

Ordering code

Ordering code of valves

2WA 150 15 A □ □
 ① ② ③ ④ ⑤ ⑥

① Model	② Orifice size	③ Port size	④ Voltage	⑤ Electrical entry	⑥ Thread type
2WA: 2/2 way internally piloted and normally closed	150: Φ15mm	15: 1/2"	A: AC220V B: DC24V	Blank: Terminal I: Grommet [Note]	Blank: PT G: G T: NPT
	200: Φ20mm	20: 3/4"	C: AC110V E: AC24V		
	250: Φ25mm	25: 1"	F: DC12V		

[Note] The wire length is 0.5m.

Ordering code of accessories

F-2WA150 LB
 ① ② ③

① Accessories code	② Valve type	③ Accessories type
F: Mounting accessories	2WA150: 150 Series valve 2WA200: 200 Series valve 2WA250: 250 Series valve	LB: LB Type



Fluid control valve(2/2way)

2WA Series (Internally piloted and normally closed)

Flow chart

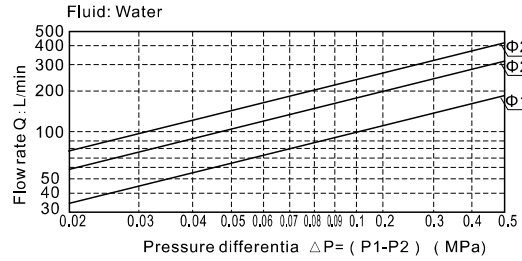
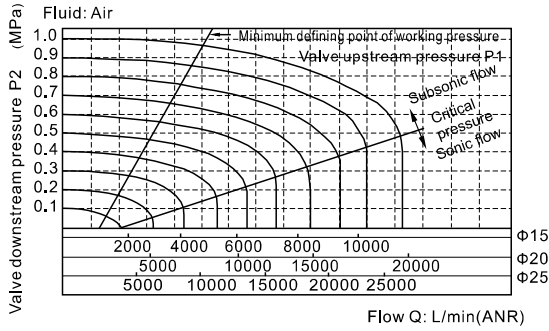

Dimensions

Terminal

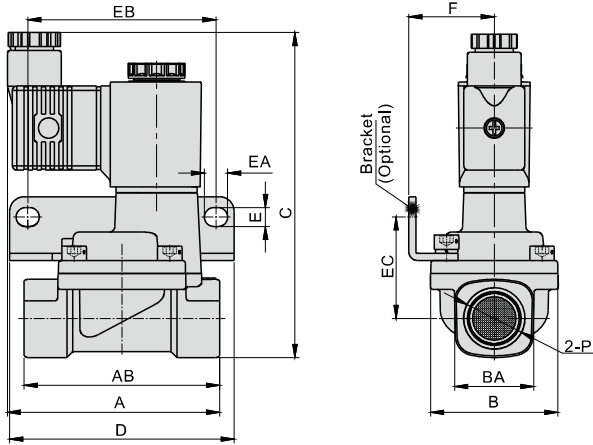

Model\Item	A	AB	B	BA	C	D	E	EA	EB	EC	F	P
2WA150-15	73.5	67.5	44	27.5	112	77.5	6.5	8	65	35	29.5	1/2"
2WA200-20	75.5	79.5	51	33	119	87.5	6.5	8	75	38	33	3/4"
2WA250-25	77.5	90	57	40	126	93	6.5	8	80	42	35	1"

Grommet

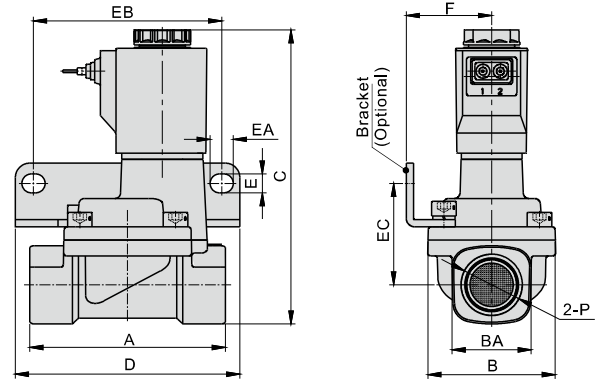

Model\Item	A	B	BA	C	D	E	EA	EB	EC	F	P
2WA150-15	67.5	44	27.5	102	77.5	6.5	8	65	35	29.5	1/2"
2WA200-20	79.5	51	33.5	109	87.5	6.5	8	75	38	33	3/4"
2WA250-25	90	57	40.5	116	93	6.5	8	80	42	35	1"

Fluid control valve(2/2 way)

2KWA Series (Direct-acting and normally opened)



Symbol



Product feature

1. Direct acting and normally opened type 2/2 way fluid valve. Its high sensibility allows it to change direction quickly;
2. It has wide pressure range, including extra high pressure (X), high pressure (H), standard and large volume(L) to choose from;
3. It is compact, small size and light weight. Easy to install and dismantle.
4. The valve body is made of brass. Its coil has a Heat resistance classification of Class F. The standard seal material is FPM-F. Please contact us if other seal material are required.
5. The protection class of the coil is IP65 and there is a choice for grommet or terminal electrical entry.

Inner structure

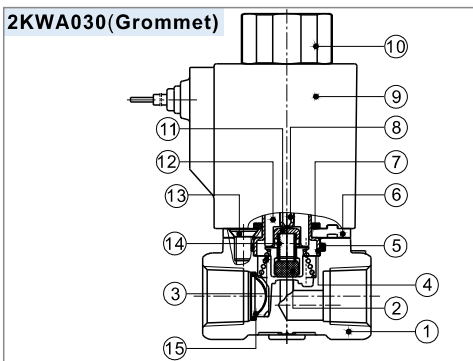

No.	Item	No.	Item	No.	Item
1	Body	6	Fixed plate	11	Airtight bush
2	Airtight ring	7	O-ring	12	Electromagnet
3	Spring	8	Mandril	13	Screw
4	Coil axis	9	Coil assembly	14	Spring
5	O-ring	10	Coil nut	15	Filter

Specification

Model\Item	Port size [Note1]	Cv	Orifice size (Φmm)	Valid area or section (mm ²)	Weight [Note2](g)	Max.operating pressure differentia		Proof pressure	
						MPa	psi	Mpa	psi
2KWAX030	-06 1/8"	0.10	1.5	1.8	245	2.0	300	3.0	450
	-08 1/4"				235				
2KWAH030	-06 1/8"	0.18	2.0	3.0	245	1.5	220		
	-08 1/4"				235				
2KWA030	-06 1/8"	0.33	3.0	6.0	245	0.7	100		
	-08 1/4"				235				
2KWAL030	-06 1/8"	0.55	4.0	10.0	245	0.4	60		
	-08 1/4"				235				
2KWAX050	-10 3/8"	0.34	3.0	6.1	530	2.0	300		
	-15 1/2"				510				
2KWAH050	-10 3/8"	0.55	4.0	10.0	530	1.5	220		
	-15 1/2"				510				
2KWA050	-10 3/8"	0.83	5.0	15.0	530	0.7	100		
	-15 1/2"				510				
2KWAL050	-10 3/8"	1.40	7.0	25.0	530	0.4	60		
	-15 1/2"				510				

[Note1] PT thread, G thread and NPT thread are available.

[Note2] The weight in the table is the terminal valve's weight, 2KWA030 series grommet valve's weight is 10g less than terminal's, 2KWA050 series grommet valve's weight is 20g less than terminal's.

Specification of coil

Valve type	Coil type	Power type	Frequency (Hz)	Voltage range	Electrical entry	Power Consumption (VA/W)	Insulation	Temp. rise(°C)
2KWA□030	CDA110 CLA110	AC	50	±15%	Terminal (CDA)	15.0VA	Class F	50
			60			11.0VA		45
		DC	-	±10%		6.5W		50
2KWA□050	CDA160 CLA160	AC	50	±15%	Grommet (CLA)	35.0VA		65
			60			30.0VA		60
		DC	-	±10%		12.0W		50

Valve's specification

Acting		Direct acting			
Initial state		Normally opened			
Adaptable fluid		Air, Water, Oil			
Viscosity limit		Under 20CST			
Ambient and fluid temperature (°C)		Water	Air	Oil	Ambient
	Max.	80	90	80	70
	Min.	1	-20 [Note1]	-10 [Note2]	-20

[Note1] Dew point: -20(°C) or less ;

[Note2] 50CST or less.

Ordering code

Ordering code of valves

2KWA H 030 08 A □ □

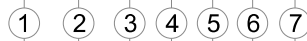

① Model	② Pressure condition	③ Size series	④ Port size	⑤ Voltage	⑥ Electrical entry	⑦ Thread type
2KWA: 2/2 way direct-acting and normally opened	X: Extra high pressure H: High pressure Blank: Standard L: Large volume	030: 030 Series 050: 050 Series	06: 1/8" 08: 1/4" 10: 3/8" 15: 1/2"	A: AC220V B: DC24V C: AC110V E: AC24V F: DC12V	Blank: Terminal I: Grommet[Note]	Blank: PT G: G T: NPT

[Note] The wire length is 0.5m.

Ordering code of accessories

Ordering code of accessories is the same as 2WA series valve's, Please refer to P169 for details of ordering code.



Fluid control valve(2/2 way)

2KWA Series (Direct-acting and normally opened)



Flow chart

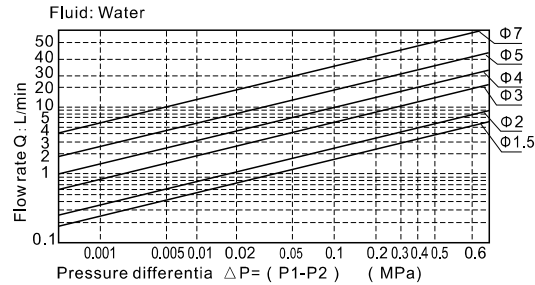
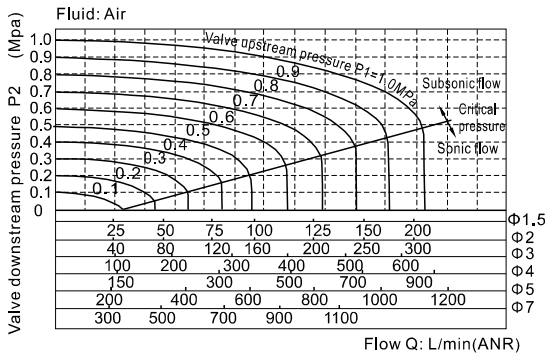

Dimensions

2KWA□030 (Terminal)

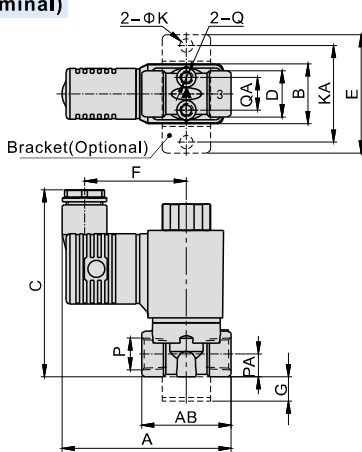

2KWA□030 (Grommet)

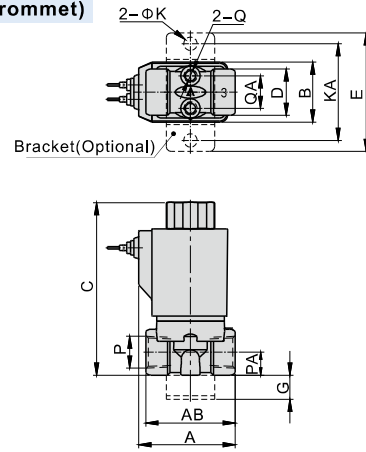

2KWA□050 (Terminal)

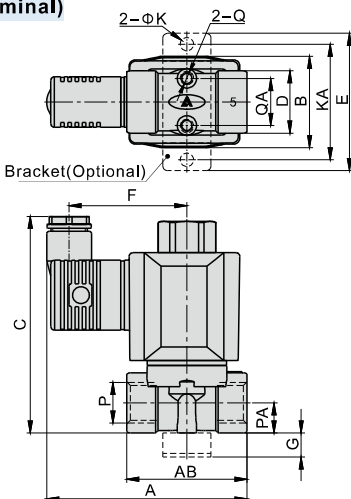

2KWA□050 (Grommet)

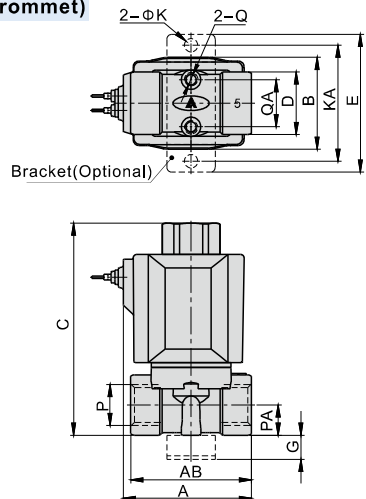

Model\Item	A	AB	B	C	D	E	F	G	K	KA	P	PA	Q	QA
2KWA□030-06	70	37	25	77.5	19	49	42	10	5.5	40	1/8"	9.5	M5	13.5
2KWA□030-08	70	37	25	77.5	19	49	42	10	5.5	40	1/4"	9.5	M5	13.5
2KWA□050-10	83	50	38	90	26	57	49	10	5.5	48	3/8"	12.5	M5	19.5
2KWA□050-15	83	50	38	90	26	57	49	10	5.5	48	1/2"	12.5	M5	19.5

Model\Item	A	AB	B	C	D	E	G	K	KA	P	PA	Q	QA
2KWA□030-06	40	37	25	74	19	49	10	5.5	40	1/8"	9.5	M5	13.5
2KWA□030-08	40	37	25	74	19	49	10	5.5	40	1/4"	9.5	M5	13.5
2KWA□050-10	53	50	38	90	26	57	10	5.5	48	3/8"	12.5	M5	19.5
2KWA□050-15	53	50	38	90	26	57	10	5.5	48	1/2"	12.5	M5	19.5



Fluid control valve(2/2 way)

2KWA Series (Internally piloted and normally opened)



Specification

Model\Item	Port size [Note1]	Orifice size (Φmm)	Cv	Valid area or section (mm ²)	Weight [Note2](g)	Operating pressure differential		Proof pressure	
						MPa	psi	MPa	psi
2KWA150-15	1/2"	15.0	5.50	100.0	575	Max: 0.7 Min: 0.05	Max: 100 Min: 10	1.5	220
2KWA200-20	3/4"	20.0	9.50	170.0	735				
2KWA250-25	1"	25.0	12.5	220.0	1035				

[Note1] PT thread, G thread and NPT thread are available.

[Note2] The weight in the table is the terminal valve's weight, grommet valve's weight is 10g less than terminal's.

Specification of coil

Valve type	Coil type	Power type	Frequency (Hz)	Voltage range	Electrical entry	Power Consumption (VA/W)	Insulation	Temp. rise(°C)
2KWA150	CDA110	AC	50	±15%	Terminal (CDA)	15.0VA	Class F	50
2KWA200	CLA110		60			11.0VA		45
2KWA250		DC	-	±10%	Grommet (CLA)	6.5W		50

Symbol



Product feature

1. Indirect acting (Internal pilot) and normally opened type 2/2 way fluid valve. It can change direction quickly and has large flow.
2. It is compact, small and light weight. Easy to install and dismantle;
3. The valve body is made of brass. The coil has a Heat resistance classification of Class F. The standard seal material is FPM-F. Please contact us if other seal material are required.
4. The protection class of the coil is IP65 and there is a choice for grommet or terminal electrical entry.

Valve's specification

Acting	Internally piloted				
	Initial state	Normally opened			
Adaptable fluid	Air, Water, Oil				
Viscosity limit	Under 20CST				
Ambient and fluid temperature (°C)		Water	Air	Oil	Ambient
	Max.	80	90	80	70
	Min.	1	-20 [Note1]	-10 [Note2]	-20

[Note1] Dew point: -20(°C) or less ;

[Note2] 50CST or less.

Inner structure

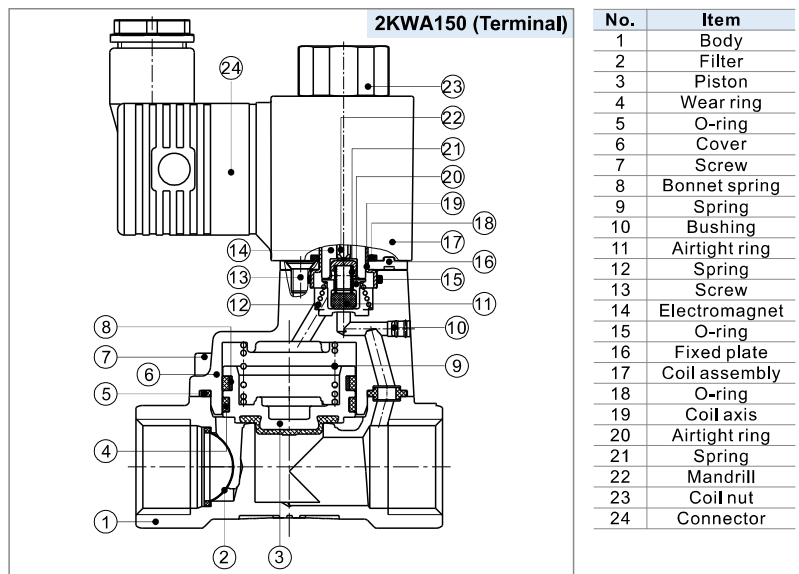

Ordering code

Ordering code of valves

2KWA 150 15 A □ □
① ② ③ ④ ⑤ ⑥

① Model	② Orifice size	③ Port size	④ Voltage	⑤ Electrical entry	⑥ Thread type
2KWA: 2/2 way internally piloted and normally opened	150: Φ15mm	15: 1/2"	A: AC220V B: DC24V C: AC110V E: AC24V F: DC12V	Blank: Terminal I: Grommet [Note]	Blank: PT G: G T: NPT
	200: Φ20mm	20: 3/4"			
	250: Φ25mm	25: 1"			

[Note] The wire length is 0.5m.

Ordering code of accessories

Ordering code of accessories is the same as 2WA series valve's, Please refer to P171 for details of ordering code.



Fluid control valve(2/2 way)

2KWA Series (Internally piloted and normally opened)



Flow chart

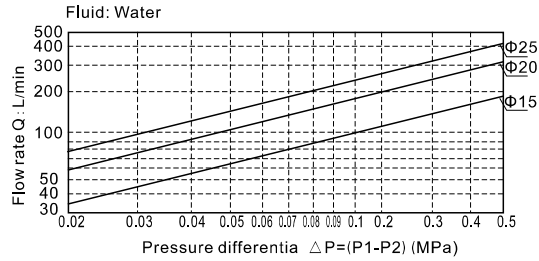
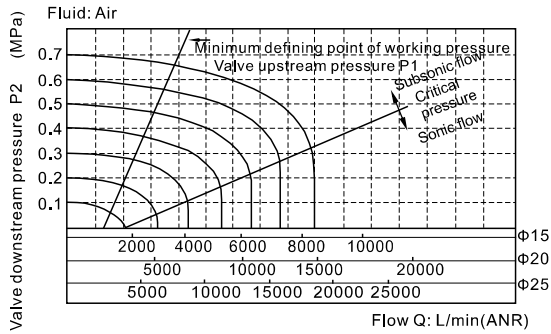

Dimensions

Terminal

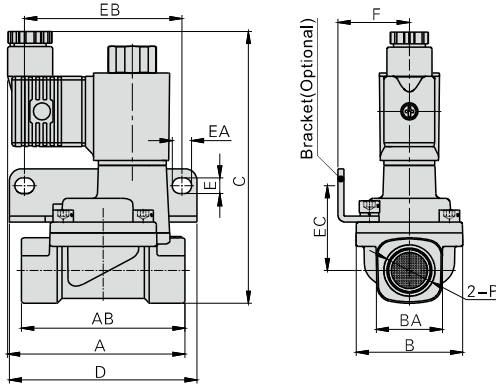

Grommet

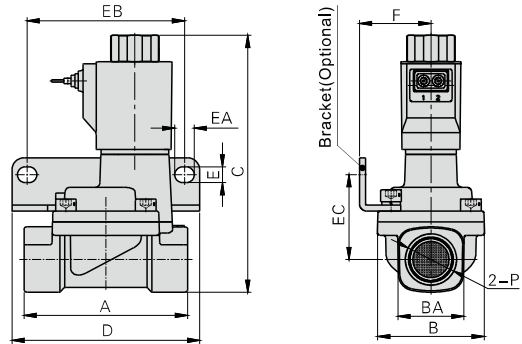

Model\Item	A	AB	B	BA	C	D	E	EA	EB	EC	F	P
2KWA150-15	73.5	67.5	44	27.5	112	77.5	6.5	8	65	35	29.5	1/2"
2KWA200-20	75.5	79.5	51	33.5	119	87.5	6.5	8	75	38	33	3/4"
2KWA250-25	77.5	90	57	40.5	126	93	6.5	8	80	42	35	1"

Model\Item	A	B	BA	C	D	E	EA	EB	EC	F	P
2KWA150-15	67.5	44	27.5	109	77.5	6.5	8	65	35	29.5	1/2"
2KWA200-20	79.5	51	33.5	116	87.5	6.5	8	75	38	33	3/4"
2KWA250-25	90	57	40.5	123	93	6.5	8	80	42	35	1"