

Air valve(5/2 way, 5/3 way)

4A100 Series



Specification

Model	4A110-M5 4A120-M5	4A130C-M5 4A130E-M5 4A130P-M5	4A110-06 4A120-06	4A130C-06 4A130E-06 4A130P-06
Fluid	Air(to be filtered by 40µm filter element)			
Acting	Exterior control			
Port size [Note1]	In=Out=M5		In=Out=1/8"	
Orifice size(Cv) [Note4]	4A110-06,4A120-06:10,2mm ² (Cv=0.6) 4A130C-06:8.6mm ² (Cv=0.51)			
Valve type	5 port 2 position	5 port 3 position	5 port 2 position	5 port 3 position
Operating pressure	0.15~0.8MPa(21~114psi)			
Proof pressure	1.2MPa(175psi)			
Temperature	-20~70°C			
Material of body	Aluminum alloy			
Lubrication [Note2]	Not required			
Max. frequency [Note3]	5 cycle/sec	3 cycle/sec	5 cycle/sec	3 cycle/sec
Weight (g)	4A110-M5:85 4A120-M5:140	165	4A110-06:85 4A120-06:140	165

Symbol

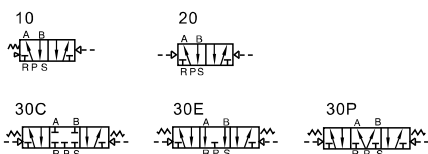

[Note1] PT thread, G thread and NPT thread are available.

[Note2] Once lubricated air is used, continue with same medium to optimise valve life span. Lubricants like ISO VG32 or equivalent are recommended.

[Note3] The maximum actuation frequency of no-load state.

[Note4] Equivalent orifice S and Cv are all calculated from the flow rate data.

Product feature

1. Structure in sliding column mode: good tightness and sensitive reaction.
2. Three position air valves have three kinds of central function for your choice.
3. Double air control valves have memory function.
4. Internal hole adopts special processing technology which has little attrition friction, low start pressure and long service life.
5. No need to add oil for lubrication.
6. Integrate with the manifold to save installation space.

Ordering code

4A 1 10 06 □

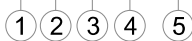

① Model	② Code	③ Valve type	④ Port size	⑤ Thread type
4A: Air Valve(5/2, 5/3 way)	1: 100 Series	10: Single air control 5/2 way 20: Double air control 5/2 way 30C: Double air control 5/3 way closed center 30E: Double air control 5/3 way exhaust center 30P: Double air control 5/3 way pressure center	M5: M5 06: 1/8"	No this code Blank: PT G: G T: NPT

Please refer to P129 for manifold specification and the order way.

Flow chart

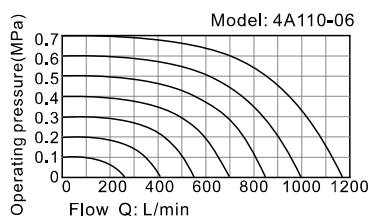

The data in flow rate chart are obtained from AirTAC lab.

Air valve(5/2 way, 5/3 way)



4A100 Series

Inner structure

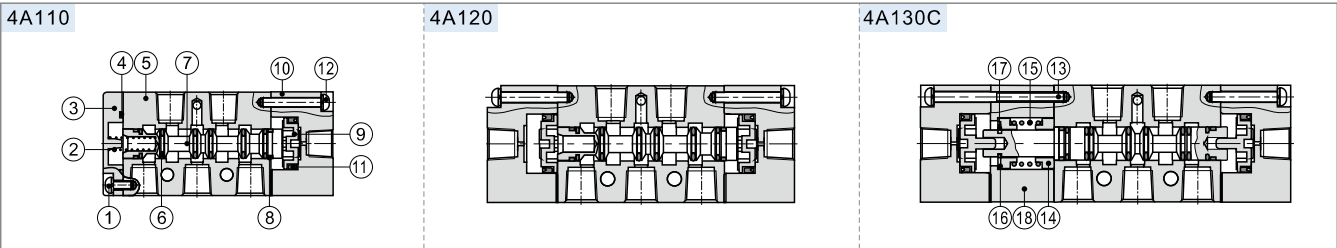

No.	Item	No.	Item	No.	Item	No.	Item	No.	Item	No.	Item	No.	Item	No.	Item
1	Screw	3	Bottom cover	5	Body	7	Spool	9	Piston	11	O-ring	13	Screw	15	Return Spring
2	Spring	4	Bottom cover gasket	6	O-ring	8	Wear ring	10	Pilot body	12	Screw	14	Spring holder	16	Spring holder
														17	E Clip
														18	Side cover

Dimension

4A110

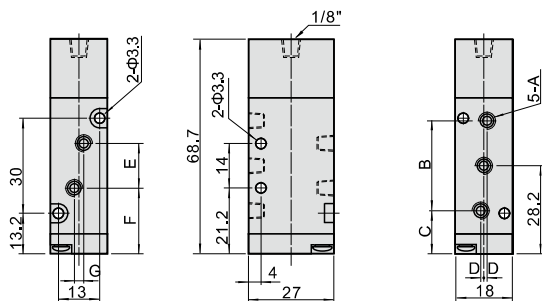

Model\Item	A	B	C	D	E	F	G
4A110-M5	M5x0.8	27	14.7	0	14	21.2	0
4A110-06	1/8"	28	14.2	1	16	20.2	3

4A120

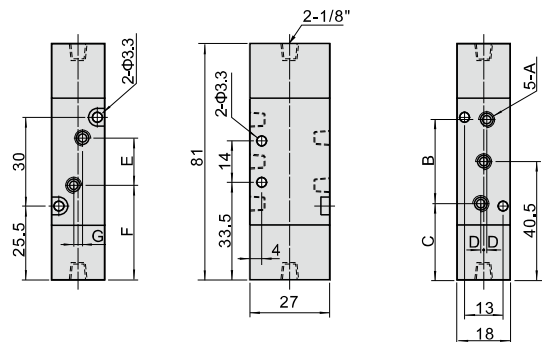

Model\Item	A	B	C	D	E	F	G
4A120-M5	M5x0.8	27	27	0	14	33.5	0
4A120-06	1/8"	28	26.5	1	16	32.5	3

4A130

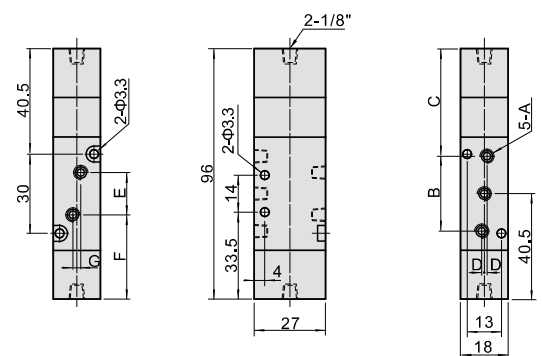

Model\Item	A	B	C	D	E	F	G
4A130-M5	M5x0.8	27	42	0	14	33.5	0
4A130-06	1/8"	28	41.5	1	16	32.5	3



Air valve(5/2 way, 5/3 way)



4A200 Series



Specification

Model	4A210-06 4A220-06	4A230C-06 4A230E-06 4A230P-06	4A210-08 4A220-08	4A230C-08 4A230E-08 4A230P-08
Fluid	Air(to be filtered by 40µm filter element)			
Acting	Exterior control			
Port size [Note1]	In=Out=Exhaust=1/8"		In=Out=1/4" Exhaust=1/8"	
Orifice size(Cv) [Note4]	4A210-08, 4A220-08: 17.0mm ² (Cv=1.0) 4A230C-08: 13.6mm ² (Cv=0.8)			
Valve type	5 port 2 position	5 port 3 position	5 port 2 position	5 port 3 position
Operating pressure	0.15~0.8MPa(21~114psi)			
Proof pressure	1.2MPa(175psi)			
Temperature	-20~70°C			
Material of body	Aluminum alloy			
Lubrication [Note2]	Not required			
Max. frequency [Note3]	5 cycle/sec	3 cycle/sec	5 cycle/sec	3 cycle/sec
Weight (g)	4A210-06:185 4A220-06:285	365	4A210-08:185 4A220-08:285	365

Symbol

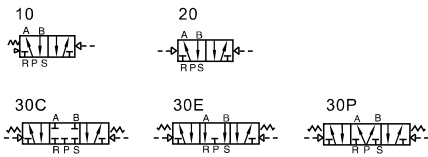

[Note1] PT thread, G thread and NPT thread are available.

[Note2] Once lubricated air is used, continue with same medium to optimise valve life span. Lubricants like ISO VG32 or equivalent are recommended.

[Note3] The maximum actuation frequency of no-load state.

[Note4] Equivalent orifice S and Cv are all calculated from the flow rate data.

Product feature

1. Structure in sliding column mode: good tightness and sensitive reaction.
2. Three position air valves have three kinds of central function for your choice.
3. Double air control valves have memory function.
4. Internal hole adopts special processing technology which has little attrition friction, low start pressure and long service life.
5. No need to add oil for lubrication.
6. Integrate with the manifold to save installation space.

Ordering code

4A 2 10 08 □



① Model	② Code	③ Valve type	④ Port size	⑤ Thread type
4A: Air Valve(5/2, 5/3 way)	2: 200 Series	10: Single air control 5/2 way 20: Double air control 5/2 way 30C: Double air control 5/3 way closed center 30E: Double air control 5/3 way exhaust center 30P: Double air control 5/3 way pressure center	06: 1/8" 08: 1/4"	Blank: PT G: G T: NPT

Please refer to P129 for manifold specification and the order way.

Flow chart

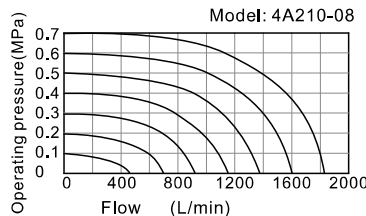

The data in flow rate chart are obtained from AirTAC lab.



Air valve(5/2 way, 5/3 way)

4A200 Series

Inner structure

4A210

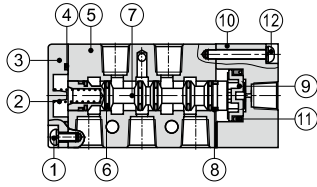

4A220

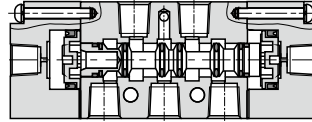

4A230C

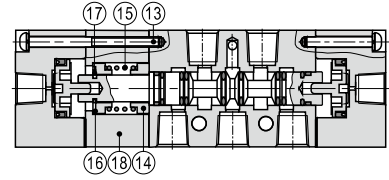

No.	Item	No.	Item	No.	Item	No.	Item	No.	Item	No.	Item	No.	Item	No.	Item
1	Screw	3	Bottom cover	5	Body	7	Spool	9	Piston	11	O-ring	13	Screw	15	Return Spring
2	Spring	4	Bottom cover gasket	6	O-ring	8	Wear ring	10	Pilot body	12	Screw	14	Spring holder	16	Spring holder
														17	E Clip
														18	Side cover

Dimension

4A210

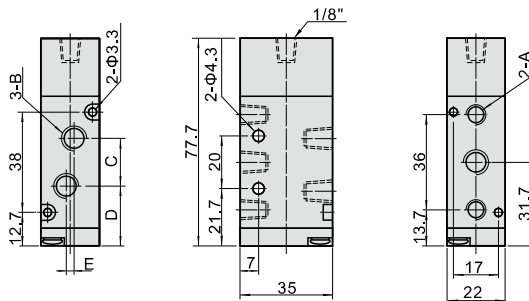

Model\Item	A	B	C	D	E
4A210-06	1/8"	1/8"	18	22.7	0
4A210-08	1/8"	1/4"	21	21.2	3

4A220

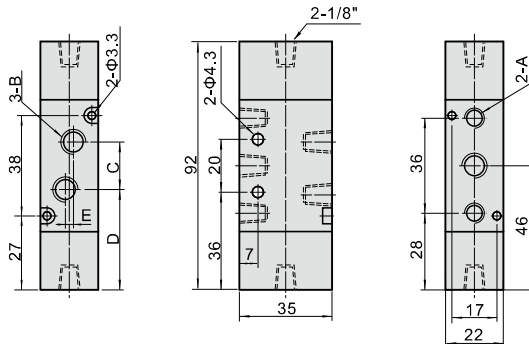

Model\Item	A	B	C	D	E
4A220-06	1/8"	1/8"	18	37	0
4A220-08	1/8"	1/4"	21	35.5	3

4A230

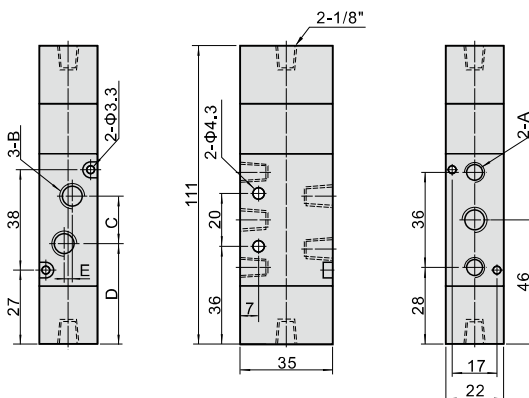

Model\Item	A	B	C	D	E
4A230-06	1/8"	1/8"	18	37	0
4A230-08	1/8"	1/4"	21	35.5	3

Air valve(5/2 way, 5/3 way)



4A300 Series



Specification

Model	4A310-08 4A320-08	4A330C-08 4A330E-08 4A330P-08	4A310-10 4A320-10	4A330C-10 4A330E-10 4A330P-10
Fluid	Air(to be filtered by 40µm filter element)			
Acting	Exterior control			
Port size [Note1]	In=Out=Exhaust=1/4"		In=Out=3/8" Exhaust=1/4"	
Orifice size(Cv) [Note4]	4A310-10,4A320-10:28.0mm ² (Cv=1.65) 4A330C-10:21.3mm ² (Cv=1.25)			
Valve type	5 port 2 position	5 port 3 position	5 port 2 position	5 port 3 position
Operating pressure	0.15~0.8MPa(21~114psi)			
Proof pressure	1.2MPa(175psi)			
Temperature	-20~70°C			
Material of body	Aluminum alloy			
Lubrication [Note2]	Not required			
Max. frequency [Note3]	4 cycle/sec	3 cycle/sec	4 cycle/sec	3 cycle/sec
Weight (g)	4A310-08:275 4A320-08:365	505	4A310-10:275 4A320-10:365	505

Symbol

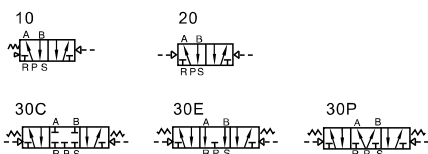

[Note1] PT thread, G thread and NPT thread are available.

[Note2] Once lubricated air is used, continue with same medium to optimise valve life span. Lubricants like ISO VG32 or equivalent are recommended.

[Note3] The maximum actuation frequency of no-load state.

[Note4] Equivalent orifice S and Cv are all calculated from the flow rate data.

Product feature

1. Structure in sliding column mode: good tightness and sensitive reaction.
2. Three position air valves have three kinds of central function for your choice.
3. Double air control valves have memory function.
4. Internal hole adopts special processing technology which has little attrition friction, low start pressure and long service life.
5. No need to add oil for lubrication.
6. Integrate with the manifold to save installation space.

Ordering code

4A 3 10 10 □
① ② ③ ④ ⑤

① Model	② Code	③ Valve type	④ Port size	⑤ Thread type
4A: Air Valve(5/2, 5/3 way)	3: 300 Series	10: Single air control 5/2 way 20: Double air control 5/2 way 30C: Double air control 5/3 way closed center 30E: Double air control 5/3 way exhaust center 30P: Double air control 5/3 way pressure center	08: 1/4" 10: 3/8"	Blank: PT G: G T: NPT

Please refer to P129 for manifold specification and the order way.

Flow chart

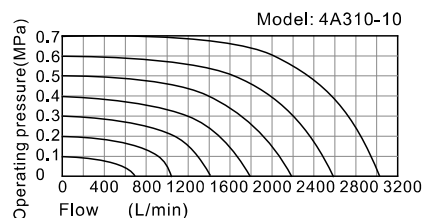

The data in flow rate chart are obtained from AirTAC lab.



Air valve(5/2 way, 5/3 way)

4A300 Series

Inner structure

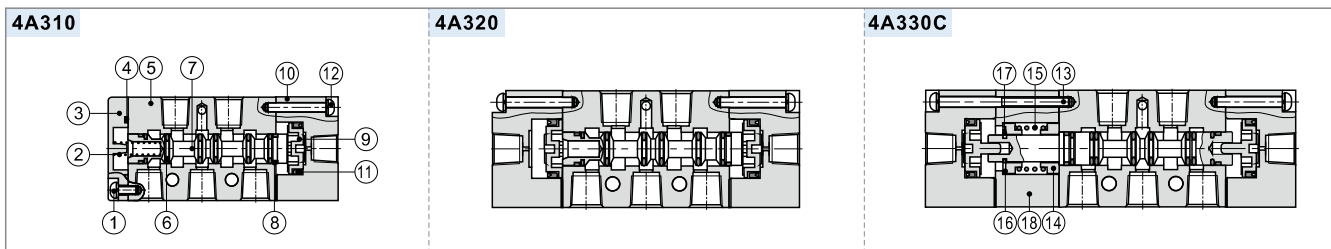

No.	Item	No.	Item	No.	Item	No.	Item	No.	Item	No.	Item	No.	Item	No.	Item
1	Screw	3	Bottom cover	5	Body	7	Spool	9	Piston	11	O-ring	13	Screw	15	Return Spring
2	Spring	4	Bottom cover gasket	6	O-ring	8	Wear ring	10	Pilot body	12	Screw	14	Spring holder	16	Spring holder
														17	E Clip
														18	Side cover

Dimension

4A310

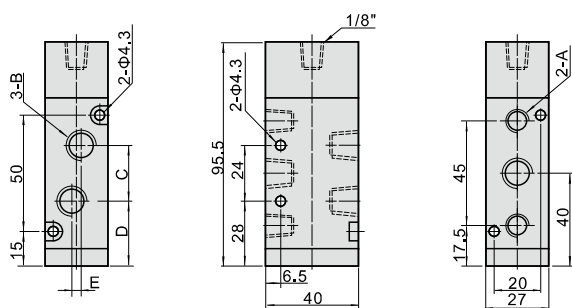

Model\Item	A	B	C	D	E
4A310-08	1/4"	1/4"	22	29	0
4A310-10	1/4"	3/8"	24	28	4

4A320

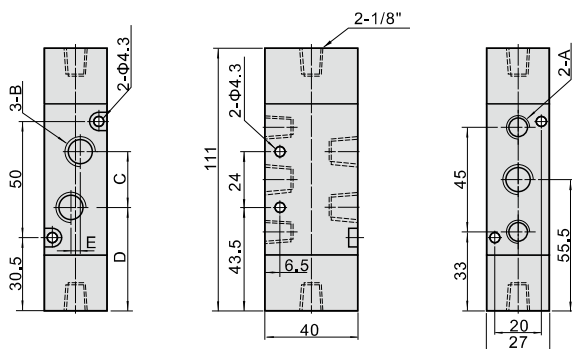

Model\Item	A	B	C	D	E
4A320-08	1/4"	1/4"	22	44.5	0
4A320-10	1/4"	3/8"	24	43.5	4

4A330

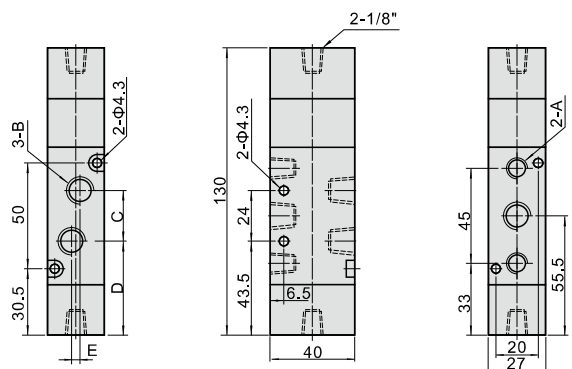

Model\Item	A	B	C	D	E
4A330-08	1/4"	1/4"	22	44.5	0
4A330-10	1/4"	3/8"	24	43.5	4

Air valve(5/2 way, 5/3 way)



4A400 Series



Specification

Model	4A410-15	4A420-15	4A430C-15	4A430E-15	4A430P-15
Fluid	Air(to be filtered by 40μm filter element)				
Acting	Exterior control				
Port size [Note1]	In=Out=Exhaust=1/2"				
Orifice size(Cv) [Note4]	4A410-15, 4A420-15:48.0mm ² (Cv=2.82) 4A430C-15:40.0mm ² (Cv=2.35)				
Valve type	5 port 2 position		5 port 3 position		
Operating pressure	0.15~0.8MPa(21~114psi)				
Proof pressure	1.2MPa(175psi)				
Temperature	-20~70 °C				
Material of body	Aluminum alloy				
Lubrication [Note2]	Not required				
Max. frequency [Note3]	3 cycle/sec				
Weight (g)	555	685		735	

[Note1] PT thread, G thread and NPT thread are available.

[Note2] Once lubricated air is used, continue with same medium to optimise valve life span. Lubricants like ISO VG32 or equivalent are recommended.

[Note3] The maximum actuation frequency of no-load state.

[Note4] Equivalent orifice S and Cv are all calculated from the flow rate data.

Symbol

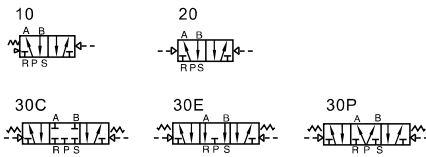

Product feature

1. Structure in sliding column mode: good tightness and sensitive reaction.
2. Three position air valves have three kinds of central function for your choice.
3. Double air control valves have memory function.
4. Internal hole adopts special processing technology which has little attrition friction, low start pressure and long service life.
5. No need to add oil for lubrication.
6. Integrate with the manifold to save installation space.

Ordering code

① Model	② Code	③ Valve type	④ Port size	⑤ Thread type
4A: Air Valve(5/2, 5/3 way)	4: 400 Series	10: Single air control 5/2 way 20: Double air control 5/2 way 30C: Double air control 5/3 way closed center 30E: Double air control 5/3 way exhaust center 30P: Double air control 5/3 way pressure center	15: 1/2"	Blank: PT G: G T: NPT

Please refer to P129 for manifold specification and the order way.

Flow chart

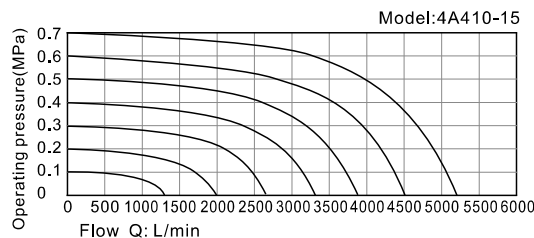

The data in flow rate chart are obtained from AirTAC lab.



Air valve(5/2 way, 5/3 way)

4A400 Series

Inner structure

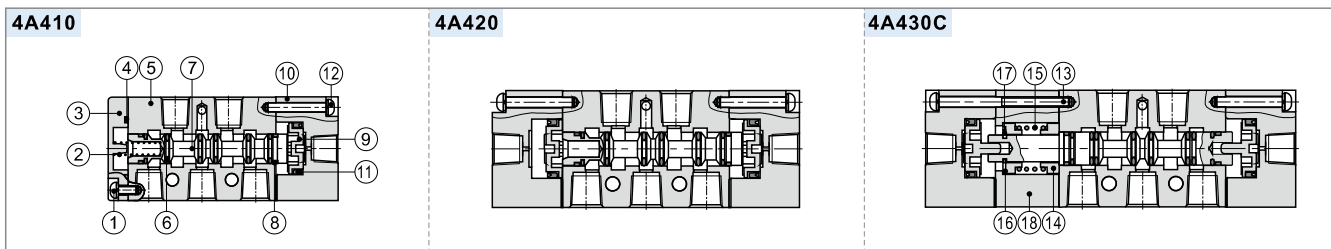

No.	Item	No.	Item	No.	Item	No.	Item	No.	Item	No.	Item	No.	Item	No.	Item	No.	Item
1	Screw	3	Bottom cover	5	Body	7	Spool	9	Piston	11	O-ring	13	Screw	15	Return Spring	17	E Clip
2	Spring	4	Bottom cover gasket	6	O-ring	8	Wear ring	10	Pilot body	12	Screw	14	Spring holder	16	Spring holder	18	Side cover

Dimension

4A410

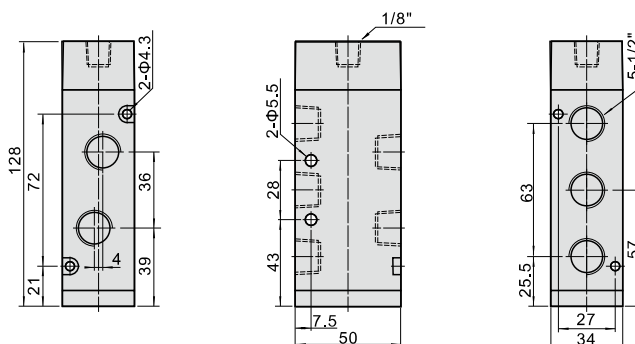

4A420

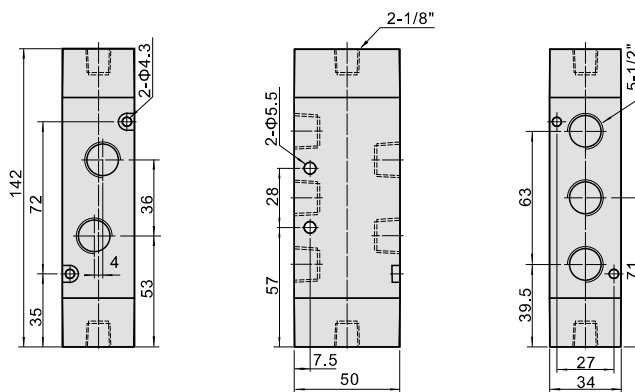

4A430

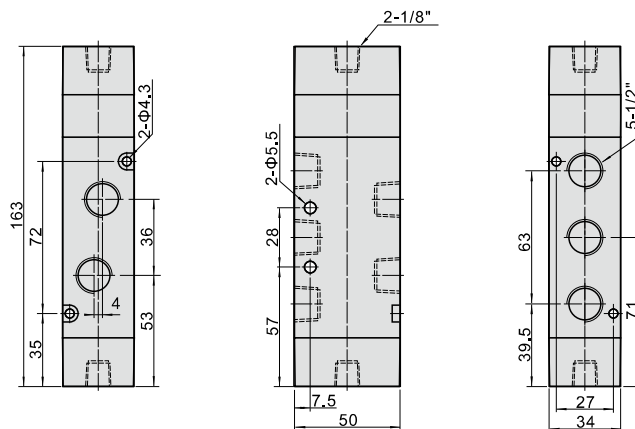

Air valve(Accessories)



Manifold



Specification

Item\Manifold Model	100M	200M	300M	400M
Fluid	Air(to be filtered by 40μm filter element)			
Temperature	-20~70°C			
Adoptable valve's series	4A100 Series	4A200 Series	4A300 Series	4A400 Series

Product feature

1. It is available to integrate the direction control valves of the same series to form valve group to save space and cost;
2. It is easy to examine when there are faults owing to the unified air intake and exhaust and unified wiring;
3. Flexible combination and strong expansion capability can make any combination or expansion of the numbers of direction control valves that are connected.

Ordering code

Ordering code for manifold

100M 5F □

① ② ③

①Model	②Number of stations [Note1]	③Thread type
100M: 100 Series Manifold	1F: 1 Station	Blank: PT G: G T: NPT
200M: 200 Series Manifold	2F: 2 Station	
300M: 300 Series Manifold	3F: 3 Station	
400M: 400 Series Manifold	
	16F: 16 Station	

[Note1] 100M, 200M series have a maximum of 16 stations ; 300M series have a maximum of 12 stations; 400M series have a maximum of 8 stations.

Ordering code for blank plate

P-100M - R2

① ② ③

①Kits code	②Model	③Code
P: Kits	100M: 100 Series Manifold 200M: 200 Series Manifold 300M: 300 Series Manifold 400M: 400 Series Manifold	R2: Blank plate for manifold

[Note] 1. Ordering code contains manifold and blank plate.
2. Manifold kits contains manifold, seal and screw.
3. Blank plate kits contains blank plate, and screw.

Dimension

With 4A air valve

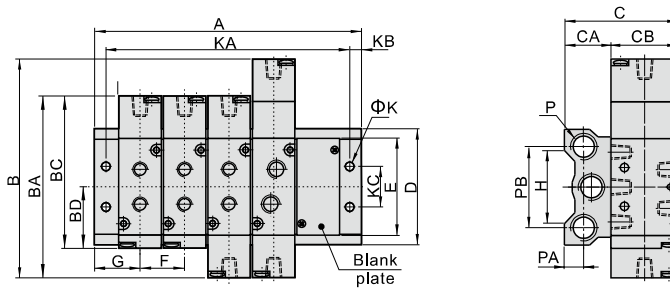

Model\Item	B	BA	BC	BD	C	CA	CB	D	E	F	G	H	K	KB	KC	P	PA	PB
100M□F	96	81	68.7	28	49	22	27	57.5	43	19	19	36	4.5	5	20	1/4"	10	40
200M□F	111	92	77.7	31.7	59	24	35	60	52	23	22	38	4.5	5	21	1/4"	10	42
300M□F	130	111	95.5	40	68	28	40	75	64	28	26	54	4.5	5	26	3/8"	13.5	53
400M□F	163	142	128	57	83	33	50	100	94	35	30.5	75	5.5	6	32	1/2"	15	68

Model\Item	A															
	1F	2F	3F	4F	5F	6F	7F	8F	9F	10F	11F	12F	13F	14F	15F	16F
100M□F	38	57	76	95	114	133	152	171	190	209	228	247	266	285	304	323
200M□F	44	67	90	113	136	159	182	205	228	251	274	297	320	343	366	389
300M□F	52	80	108	136	164	192	220	248	276	304	332	360	-	-	-	-
400M□F	61	96	131	166	201	236	271	306	-	-	-	-	-	-	-	-

Model\Item	KA															
	1F	2F	3F	4F	5F	6F	7F	8F	9F	10F	11F	12F	13F	14F	15F	16F
100M□F	28	47	66	85	104	123	142	161	180	199	218	237	256	275	294	313
200M□F	34	57	80	103	126	149	172	195	218	241	264	287	310	333	356	379
300M□F	42	70	98	126	154	182	210	238	266	294	322	350	-	-	-	-
400M□F	49	84	119	154	189	224	259	294	-	-	-	-	-	-	-	-

