

Hand lever valve (4/2 way, 4/3 way)



4HV, 4HVL Series



Symbol

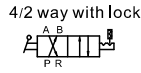
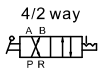

4/2 way

4/2 way with lock



4/3 way closed center

4/3 way closed center type with lock

Specification

Model	4HV2□□ -06(L)	4HV2□□ -08(L)	4HV3□□ -08(L)	4HV3□□ -10(L)	4HV4□□ -15(L)	4HV4□□ -20(L)
Fluid	Air (to be filtered by 40 μm filter element)					
Operating	Manual control direct acting type					
Port size [Note1]	1/8"	1/4"	1/4"	3/8"	1/2"	3/4"
Orifice size	14.0mm ² (Cv=0.78)	16.0mm ² (Cv=0.89)	30.0mm ² (Cv=1.67)	33.0mm ² (Cv=1.83)	88.0mm ² (Cv=4.89)	95.0mm ² (Cv=5.27)
Valve type	4/2 Way, 4/3 Way					
Lubrication	Not required					
Pressure range	0~1.0MPa(0~145psi)					
Proof pressure	1.5MPa(215psi)					
Temperature	-20~70°C					
Operating angle	90°(4/3 Way: 45°)					

[Note1] PT thread, G thread and NPT thread are available.

Product feature

1. The direction-change turns lightly with good hand feeling and exact orientation.
2. Large effective circulating area leads to little pressure loss.
3. Panel and body installation are optional. The panel installation can be attached with installing nut.

Ordering code

4HV 2 30 06 S L □



① Model	② Code	③ Valve type	④ Port size	⑤ Installation	⑥ Note	⑦ Thread type
4HV: Hand lever valve	2: 2 Series	10: 4 port 2 position 30: 4 port 3 position [Note1]	06: 1/8"	Blank: Body installation S: Panel installation [Note2]	Blank: Without lock L: With lock	Blank: PT G: G T: NPT
	3: 3 Series		08: 1/4"			
	4: 4 Series		15: 1/2" 20: 3/4"			

[Note1] 4 port 3 position only has closed center type. [Note2] The panel installation can be attached with installing nut.

Flow chart

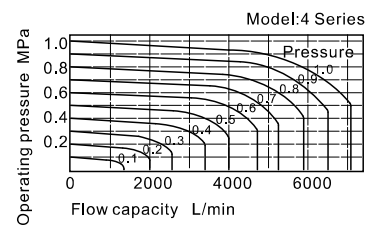
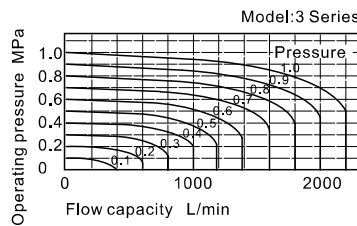
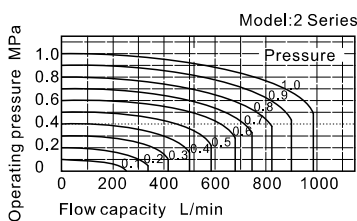

Inner structure

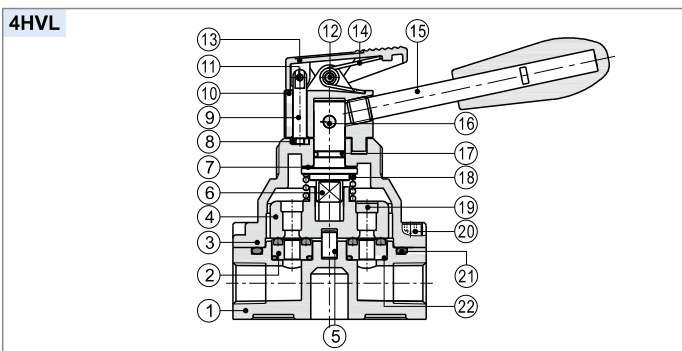

No.	Item	No.	Item
1	Body	12	Pin one
2	Seal base	13	Front cover
3	Valve cover	14	Spring
4	Valve plug	15	Handle
5	Column pin	16	Pin two
6	Shaft	17	Shaft O-ring
7	Washer	18	Spring
8	Fixing plate	19	Iron plate
9	Lock pin	20	Fixing screw
10	Valve cap	21	Body O-ring
11	Spring pin	22	Seal base O-ring



Hand lever valve (4/2 way, 4/3 way)

4HV, 4HVL Series

Dimensions

4HV

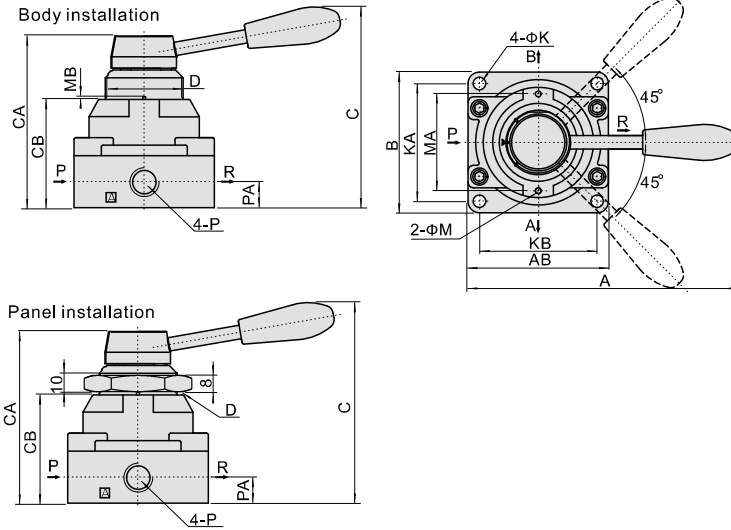

Model\Item	A	AB	B	C	CA	CB	D	K	KA	KB	M	MA	MB	P	PA
4HV2□-06	120	62	62	92.5	73	45	M34×1.5	5.5	49	49	3	40	1.5	1/8"	11.5
4HV2□-08	120	62	62	92.5	73	45	M34×1.5	5.5	49	49	3	40	1.5	1/4"	11.5
4HV3□-08	140	74	74	104	88.5	56	M40×1.5	6.5	62	62	3	51	1.5	1/4"	13.5
4HV3□-10	140	74	74	104	88.5	56	M40×1.5	6.5	62	62	3	51	1.5	3/8"	13.5
4HV4□-15	160	94	102	128	110	72	M52×1.5	6.5	89	81	3	64	2	1/2"	18
4HV4□-20	160	94	102	128	110	72	M52×1.5	6.5	89	81	3	64	2	3/4"	18

4HVL

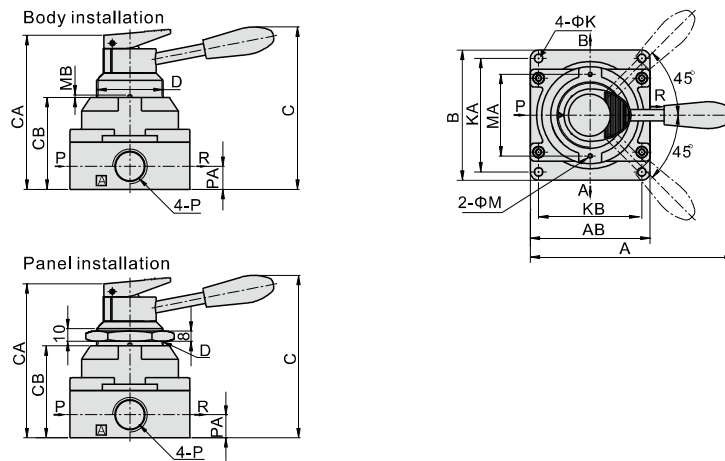

Model\Item	A	AB	B	C	CA	CB	D	K	KA	KB	M	MA	MB	P	PA
4HV2□-06L	120	62	62	92.5	84	45	M34×1.5	5.5	49	49	3	40	1.5	1/8"	11.5
4HV2□-08L	120	62	62	92.5	84	45	M34×1.5	5.5	49	49	3	40	1.5	1/4"	11.5
4HV3□-08L	140	74	74	104	99	56	M40×1.5	6.5	62	62	3	51	1.5	1/4"	13.5
4HV3□-10L	140	74	74	104	99	56	M40×1.5	6.5	62	62	3	51	1.5	3/8"	13.5
4HV4□-15L	160	94	102	128	121	72	M52×1.5	6.5	89	81	3	64	2	1/2"	18
4HV4□-20L	160	94	102	128	121	72	M52×1.5	6.5	89	81	3	64	2	3/4"	18