

# 6D/6DW Series Integrated solenoid valve (5/2, 5/3 way)

## Compendium of 6D/6DW Series

### Manual Lock Design

1. Manual push does not automatically lock, used for valve installation and debugging.
2. Use caution, prior to activating manual override.
3. With the correct size screw driver: gently press and turn to lock (Torque: 0.1N.m)



Normal Position



Lock Position

### Adaptor design of pilot valve

Easy to install with stable signaling, decreases risk during manual wiring

### Consolidate Input

The D-SUB25PIN(6D) or D-SUB37PIN(6DW) cable, simplifies wiring process and enhances risk-resisting function.

### Multi-series and Multi-port types are optional

6D0500, 6D100, 6D200 series;  
6DW0500, 6DW100, 6DW200 series;  
Φ4、Φ6、Φ8、Φ10 ports for options.

Series/Ports(A\B ports)	Φ4	Φ6	Φ8	Φ10
6D0500/6DW0500	•	•		
6D100/6DW100	•	•	•	
6D200/6DW200			•	•



### Dual Centralized inlet ports

Centralized inlet, convenient piping, saving installation space.

Series	6D0500	6D100	6D200
6DW0500	6DW100	6DW200	
Ports(P)	Φ8	Φ10	Φ12

### Dual Centralized outlet ports

Centralized exhaust, convenient piping, saving installation space.

Series	6D0500	6D100	6D200
6DW0500	6DW100	6DW200	
Ports(R)	Φ8	Φ10	Φ12

### Manifold design

It is convenient and flexible to disassemble and replace.

### DIN rail compatibility

Manifold is compatible with DIN standard rail. 6D/6DW integrated valve can be fixed at any position of rail by stopper screw.

### Diverse installation

With four bolts, it can be fixed anywhere on panel.

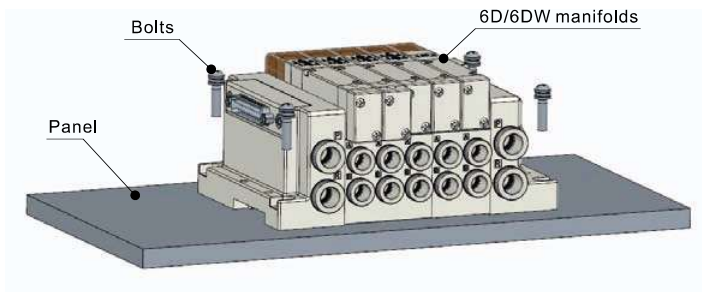
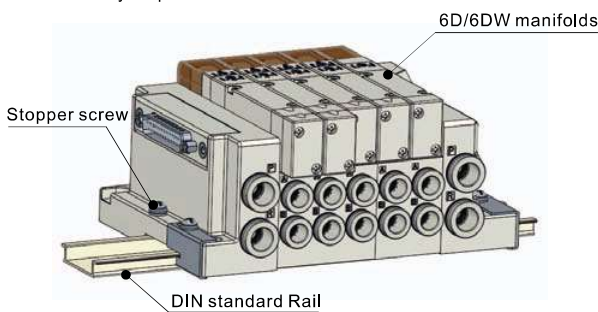

# Integrated solenoid valve (5/2, 5/3 way)



## 6D/6DW Series



### Symbol

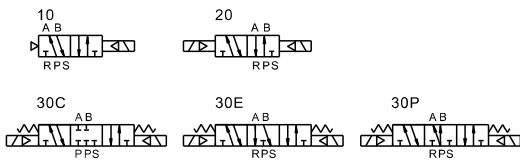

### Product feature

1. Centralized inlets, outlets and signal input(25pin D-SUB or 37pin D-SUB) make it highly simplifies installation and reduces risk during mounting.
2. Flexible combination for various applications.
3. Convenient installation, can be fixed on panel or DIN rail without other accessory.
4. 2 position and 3 position valves can be installed on the same manifold without further accessories.
5. Affiliated manual devices are equipped to facilitate installation and debugging.
6. Low starting voltage and long service life.

### Flow chart

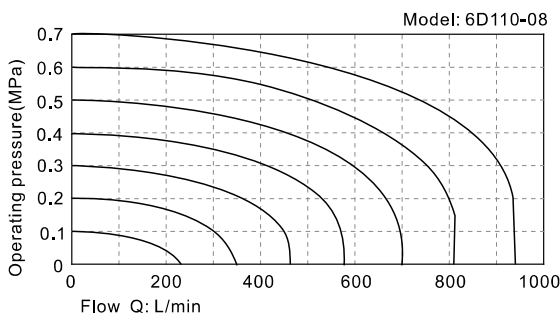
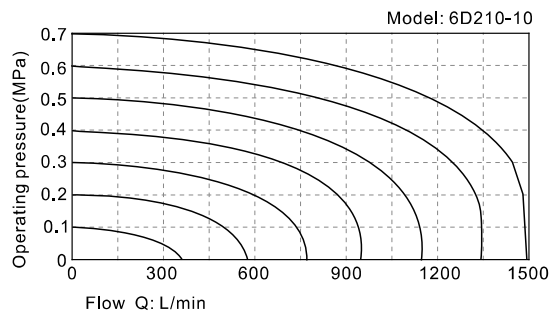
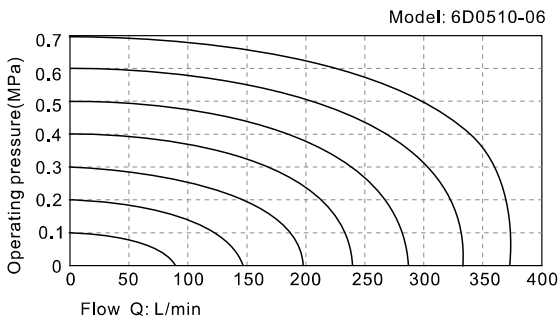

Flow rate data obtained from the AirTAC R&D Lab.

### Specification

Model	6D0500/6DW0500	6D100/6DW100	6D200/6DW200
Fluid	Air(to be filtered by 40μm filter element)		
Acting	Pilot		
Operating pressure	5/3 way	0.2~0.8MPa(29~114psi)	
	Others	0.15~0.8MPa(21~114psi)	
Proof pressure	1.2MPa(175psi)		
Temperature	-20~70°C		
Type of inlet and exhaust	Centralized inlet and exhaust		
Numbers of station	6D	3-21 stations	
	6DW	13-33 stations	
Port size	A, B ports	Φ4/Φ6 tube fitting	Φ4/Φ6/Φ8 tube fitting
	P, R ports	Φ8 tube fitting	Φ10 tube fitting
Electrical entry	Terminal , 25pinD-SUB/37pinD-SUB		

### Coil specification

Item	Specification	
Standard voltage	DC24V	DC12V
Scope of voltage	DC : ±10%	
Power of consumption	DC : 0.7W	
Protection	Dustproof	
Temperature classification	F Class	
Electrical entry	Terminal	
Activating time	0.05 sec and below	



# Integrated solenoid valve (5/2, 5/3 way)

## 6D/6DW Series

### Manifold ports Ordering Code (With Valves, 25PIN)

6D1H 8F-J06 B S1 D2 C2 E2 P1 □

① ② ③ ④ ⑤ ⑥ ⑦ ⑧ ⑨ ⑩



① Model	6D05H: 6D0500 Series integrated Solenoid valve	6D1H: 6D100 Series integrated Solenoid valve	6D2H: 6D200 Series integrated Solenoid valve
② Number of stations	3F: 3 stations    4F: 4 stations    .....    21F: 21stations		
③ Port size(A/B Port)	J04: Φ4 tube fitting J06: Φ6 tube fitting	J04: Φ4 tube fitting J06: Φ6 tube fitting J08: Φ8 tube fitting	J08: Φ8 tube fitting J10: Φ10 tube fitting
④ Standard voltage	B:DC24V    F:DC12V		
⑤ Single solenoid 5/2 way	Blank: No    S1: 1 piece    S2: 2 pieces.....S21: 21 pieces		
⑥ Double solenoid 5/2 way	Blank: No    D1: 1 piece    D2: 2 pieces.....D12: 12 pieces		
⑦ Double solenoid 5/3 way closed center	Blank: No    C1: 1 piece    C2: 2 pieces.....C12: 12 pieces		
⑧ Double solenoid 5/3 way exhaust center	Blank: No    E1: 1 piece    E2: 2 pieces.....E12: 12 pieces		
⑨ Double solenoid 5/3 way pressure center	Blank: No    P1: 1 piece    P2: 2 pieces.....P12: 12 pieces		
⑩ Type of communication module	Blank: Without communication module CPN1: Profinet+PNP    CPN2: Profinet+NPN CEN1: EtherNet/IP+PNP    CEN2: EtherNet/IP+NPN CEA1: EtherCAT+PNP    CEA2: EtherCAT+NPN CLK1: IO-Link+PNP		

Ordering code instruction:

- 6D series comes with D-SUB25PIN.
- Fill in spec, number of stations, port size, voltage in order code accordingly.
- Valve installation sequence : start from D-SUB side.
- Valve installation sequence : (1) Double solenoid 5/3 way(C→E→P). (2) Double solenoid 5/2 way. (3)Single solenoid.
- For empty position, please install provisional block.
- 0500 series in/outlet ports (P/R) is Ø8, 100 series in/outlet ports (P/R) is Ø10, 200 series in/outlet ports (P/R) is Ø12
- Less than 8 stations(inclusive):come with 1 plug type silencer and 2 plugs; More than 8 stations: come with 2 plug type silencers and 1 plug.
- Total number of single solenoids+double solenoids+5/3way(C) + 5/3way(E) + 5/3way(P) must be ≤21
- For station 3~12, total number of ⑥+⑦+⑧+⑨ must be ≤12 (come with double solenoid manifold)
- For station 13-15, total numbers of ⑥+⑦+⑧+⑨ must be ≤9 ; station 16-18, total numbers of ⑥+⑦+⑧+⑨ must be ≤6. station 19-21, total numbers of ⑥+⑦+⑧+⑨ must be ≤3.

### Manifold ports Ordering Code (Without Valves, 25PIN)

6D1H 8F J06

① ② ③



① Model	6D05H: 6D0500 Series manifold	6D1H: 6D100 Series manifold	6D2H: 6D200 Series manifold
② Number of stations	3F: 3 stations    4F: 4 stations    .....    21F: 21stations		
③ Port size(A/B Port)	J04: Φ4 tube fitting J06: Φ6 tube fitting	J04: Φ4 tube fitting J06: Φ6 tube fitting J08: Φ8 tube fitting	J08: Φ8 tube fitting J10: Φ10 tube fitting

Note:

- 6D series comes with D-SUB25PIN.
- For station 3~12, it comes with double solenoid type manifold.
  - On 13 to 15 station valve banks, only the first 9 positions can have double solenoid valves(2 or 3 positions)
  - On 16 to 18 station valve banks, only the first 6 positions can have double solenoid valves(2 or 3 positions)
  - On 19 to 21 station valve banks, only the first 3 positions can have double solenoid valves(2 or 3 positions)
- Valve installation sequence: start from D-SUB side.
- 0500 series in/outlet ports (P/R) is Ø8, 100 series in/outlet ports (P/R) is Ø10, 200 series in/outlet ports (P/R) is Ø12
- Less than 8 stations(inclusive): come with 1 plug type silencer and 2 plugs; More than 8 stations: come with 2 plug type silencers and 1 plug.

# Integrated solenoid valve (5/2, 5/3 way)



## 6D/6DW Series

### Manifold ports Ordering Code (With Valves, 37PIN)

6DW1H 18F-J06 B S5 D8C2 E1 P2 □

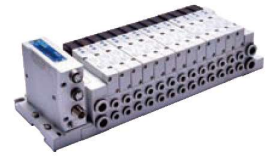

Without communication module

Without communication module

With communication module

① Model	6DW05H: 6DW0500 Series integrated Solenoid valve	6DW1H: 6DW100 Series integrated Solenoid valve	6DW2H: 6DW200 Series integrated Solenoid valve
② Number of stations	13F: 13 stations 14F: 14 stations ..... 33F: 33stations		
③ Port size(A/B Port)	J04: Φ4 tube fitting J06: Φ6 tube fitting	J04: Φ4 tube fitting J06: Φ6 tube fitting J08: Φ8 tube fitting	J08: Φ8 tube fitting J10: Φ10 tube fitting
④ Standard voltage	B:DC24V F:DC12V		
⑤ Single solenoid 5/2 way	Total number of valves	Blank: No	S1: 1 piece S2: 2 pieces.....S33: 33 pieces
⑥ Double solenoid 5/2 way		Blank: No	D1: 1 piece D2: 2 pieces.....D18: 18 pieces
⑦ Double solenoid 5/3 way closed center		Blank: No	C1: 1 piece C2: 2 pieces.....C18: 18 pieces
⑧ Double solenoid 5/3 way exhaust center		Blank: No	E1: 1 piece E2: 2 pieces.....E18: 18 pieces
⑨ Double solenoid 5/3 way pressure center		Blank: No	P1: 1 piece P2: 2 pieces.....P18: 18 pieces
⑩ Type of communication module	Blank: Without communication module CPN11: Profinet+PNP CPN22: Profinet+NPN CEN11: EtherNet/IP+PNP CEN22: EtherNet/IP+NPN CEA11: EtherCAT+PNP CEA22: EtherCAT+NPN CLK11: IO-Link+PNP		

Ordering code instruction:

- 6DW series comes with D-SUB37PIN.
- Fill in spec, number of stations, port size, voltage in order code accordingly.
- Valve installation sequence : start from D-SUB side.
- Valve installation sequence : (1) Double solenoid 5/3 way(C→E→P). (2) Double solenoid 5/2 way. (3)Single solenoid.
- For empty position, please install provisional block.
- 0500 series in/outlet ports (P/R) is Ø8, 100 series in/outlet ports (P/R) is Ø10, 200 series in/outlet ports (P/R) is Ø12
- 6DW series comes with 2 plug type silencers and 1 plug.
- Total number of single solenoids+double solenoids+5/3way(C) + 5/3way(E) + 5/3way(P) must be ≤33
- For station 13~18, total number of ⑤+⑥+⑦+⑧ must be ≤18 (come with double solenoid manifold)  
For station 19-21, total numbers of ⑤+⑥+⑦+⑧ must be ≤15. Station 22-24, total numbers of ⑤+⑥+⑦+⑧ must be ≤12.  
Station 25-27, total numbers of ⑤+⑥+⑦+⑧ must be ≤9. Station 28-30, total numbers of ⑤+⑥+⑦+⑧ must be ≤6.  
Station 31-33, total numbers of ⑤+⑥+⑦+⑧ must be ≤3.

### Manifold ports Ordering Code (Without Valves, 37PIN)

6DW1H 8F J06

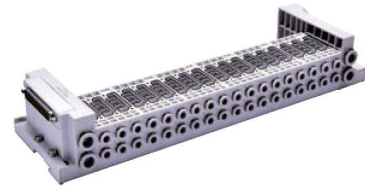
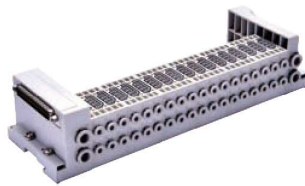

① Model	6DW05H: 6DW0500 Series manifold	6DW1H: 6DW100 Series manifold	6DW2H: 6DW200 Series manifold
② Number of stations	13F: 13 stations 14F: 14 stations ..... 33F: 33stations		
③ Port size(A/B Port)	J04: Φ4 tube fitting J06: Φ6 tube fitting	J04: Φ4 tube fitting J06: Φ6 tube fitting J08: Φ8 tube fitting	J08: Φ8 tube fitting J10: Φ10 tube fitting

Note:

- 6DW series comes with D-SUB37PIN.
- For station 13~18, it comes with double solenoid type manifold.  
On 19 to 21 station valve banks, only the first 15 positions can have double solenoid valves(2 or 3 positions).  
On 22 to 24 station valve banks, only the first 12 positions can have double solenoid valves(2 or 3 positions).  
On 25 to 27 station valve banks, only the first 9 positions can have double solenoid valves(2 or 3 positions).  
On 28 to 30 station valve banks, only the first 6 positions can have double solenoid valves(2 or 3 positions).  
On 31 to 33 station valve banks, only the first 3 positions can have double solenoid valves(2 or 3 positions).
- Valve installation sequence: start from D-SUB side.
- 0500 series in/outlet ports (P/R) is Ø8, 100 series in/outlet ports (P/R) is Ø10, 200 series in/outlet ports (P/R) is Ø12
- 6DW series comes with 2 plug type silencers and 1 plug.



# Integrated solenoid valve (5/2, 5/3 way)



## 6D/6DW Series

### Solenoid Valve Ordering Code

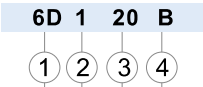

① Model	6D: 5-port, 2/3-position solenoid valve		
② Code	05: 0500 Series	1: 100 Series	2: 200 Series
③ Valve type	10 : Single solenoid(5/2 Way)    20 : Double solenoid(5/2 Way)    30C : Double solenoid(5/3 way closed center) 30E : Double solenoid(5/3 way exhaust center)    30P : Double solenoid(5/3 way pressure center)		
④ Standard Voltage	B: DC24V    F: DC12V		

### Provisional Block Ordering Code

#### P - 6D100M - R2

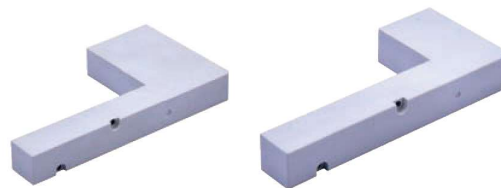

① Accessories	P : Accessories		
② Model	6D0500M: 0500 Series	6D100M: 100 Series	6D200M: 200 Series
③ Provisional block code	R2: 6D series Provisional block		

Note: Orders come with screw bolts.

### DIN Rail Ordering Code

#### F - DINX140



① Accessories	F-DIN: DIN Rail		
② Length of DIN rail	140 : 140mm	175 : 175mm	210 : 210mm .....1000 : 1000mm

Note: DIN rail add length is 35mm each step.

### Dimensions

#### 6D0500

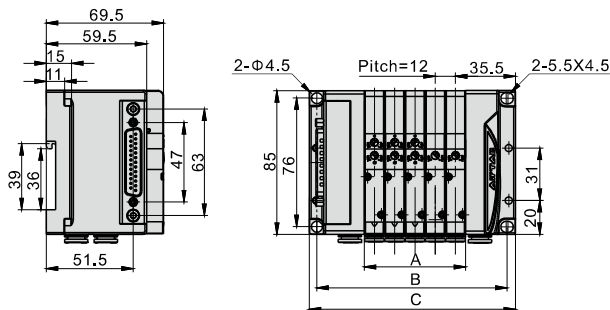

#### 6DW0500

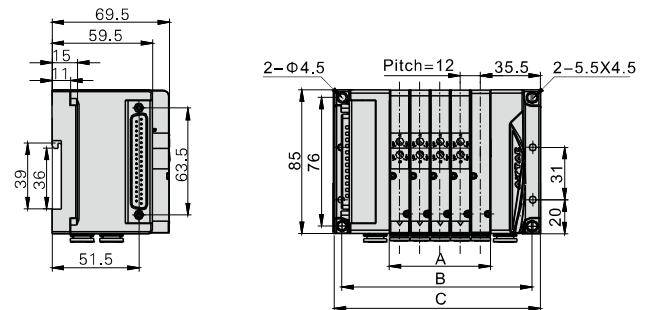

Item\Stations	3F	4F	5F	6F	7F	8F	9F	10F	11F	
A	36	48	60	72	84	96	108	120	132	
B	88.5	100.5	112.5	124.5	136.5	148.5	160.5	172.5	184.5	
C	98	110	122	134	146	158	170	182	194	
Item\Stations	12F	13F	14F	15F	16F	17F	18F	19F	20F	21F
A	144	156	168	180	192	204	216	228	240	252
B	196.5	208.5	220.5	232.5	244.5	256.5	268.5	280.5	292.5	304.5
C	206	218	230	242	254	266	278	290	302	314

Item\Stations	13F	14F	15F	16F	17F	18F	19F	20F	21F	22F	
A	156	168	180	192	204	216	228	240	252	264	
B	208.5	220.5	232.5	244.5	256.5	268.5	280.5	292.5	304.5	316.5	
C	218	230	242	254	266	278	290	302	314	326	
Item\Stations	23F	24F	25F	26F	27F	28F	29F	30F	31F	32F	33F
A	276	288	300	312	324	336	348	360	372	384	396
B	328.5	340.5	352.5	364.5	376.5	388.5	400.5	412.5	424.5	436.5	448.5
C	338	350	362	374	386	398	410	422	434	446	458



# Integrated solenoid valve (5/2, 5/3 way)



## 6D/6DW Series

### 6D100

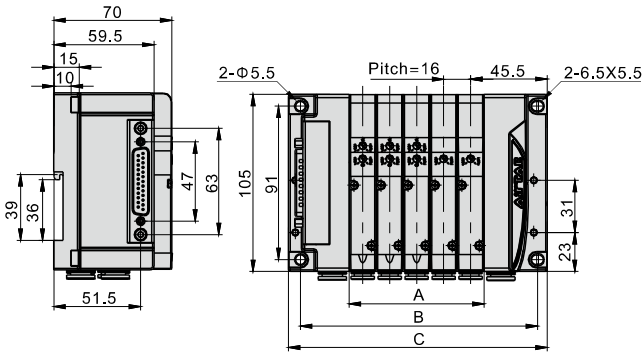

Item\Stations	3F	4F	5F	6F	7F	8F	9F	10F	11F
A	48	64	80	96	112	128	144	160	176
B	108.5	124.5	140.5	156.5	172.5	188.5	204.5	220.5	236.5
C	121.5	137.5	153.5	169.5	185.5	201.5	217.5	233.5	249.5

Item\Stations	12F	13F	14F	15F	16F	17F	18F	19F	20F	21F
A	192	208	224	240	256	272	288	304	320	336
B	252.5	268.5	284.5	300.5	316.5	332.5	348.5	364.5	380.5	396.5
C	265.5	281.5	297.5	313.5	329.5	345.5	361.5	377.5	393.5	409.5

### 6DW100

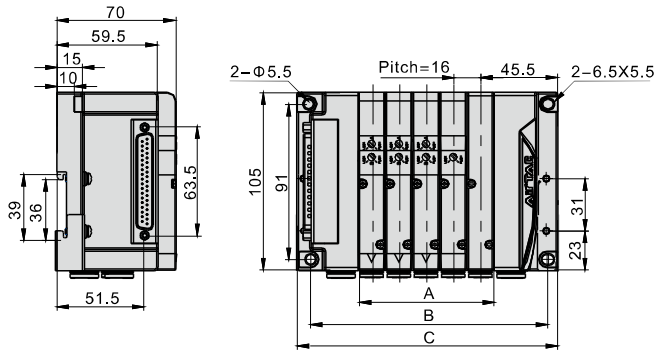

Item\Stations	13F	14F	15F	16F	17F	18F	19F	20F	21F	22F
A	208	224	240	256	272	288	304	320	336	352
B	268.5	284.5	300.5	316.5	332.5	348.5	364.5	380.5	396.5	412.5
C	281.5	297.5	313.5	329.5	345.5	361.5	377.5	393.5	409.5	425.5

Item\Stations	23F	24F	25F	26F	27F	28F	29F	30F	31F	32F	33F
A	368	384	400	416	432	448	464	480	496	512	528
B	428.5	444.5	460.5	476.5	492.5	508.5	524.5	540.5	556.5	572.5	588.5
C	441.5	457.5	473.5	489.5	505.5	521.5	537.5	553.5	569.5	585.5	601.5

### 6D200

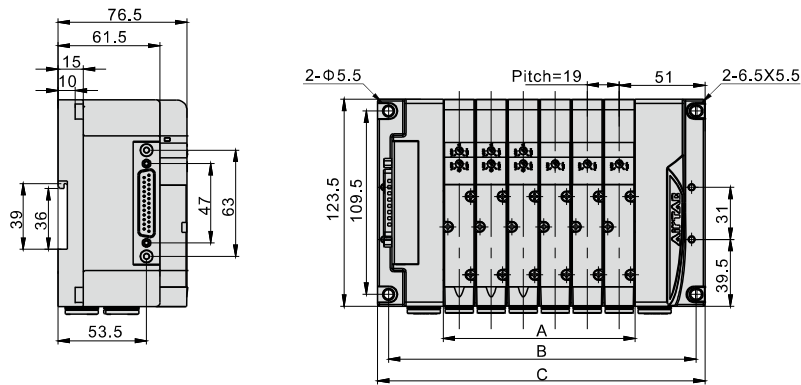

Item\Stations	3F	4F	5F	6F	7F	8F	9F	10F	11F	12F	13F	14F	15F	16F	17F	18F	19F	20F	21F
A	57	76	95	114	133	152	171	190	209	228	247	266	285	304	323	342	361	380	399
B	125.5	144.5	163.5	182.5	201.5	220.5	239.5	258.5	277.5	296.5	315.5	334.5	353.5	372.5	391.5	410.5	429.5	448.5	467.5
C	137.5	156.5	175.5	194.5	213.5	232.5	251.5	270.5	289.5	308.5	327.5	346.5	365.5	384.5	403.5	422.5	441.5	460.5	479.5

### 6DW200

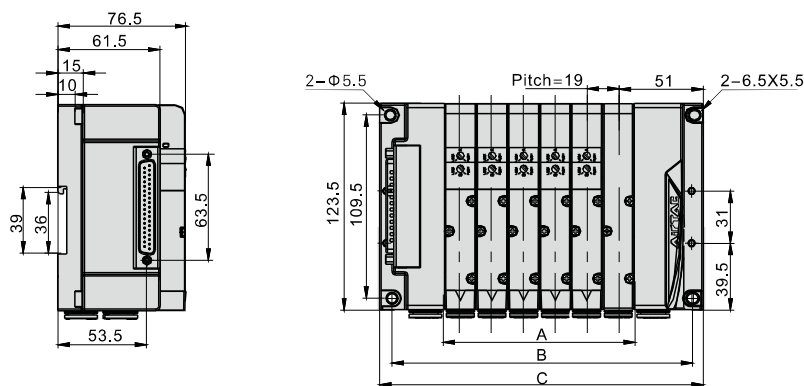

Item\Stations	13F	14F	15F	16F	17F	18F	19F	20F	21F	22F	23F	24F	25F	26F	27F	28F	29F	30F	31F	32F	33F
A	247	266	285	304	323	342	361	380	399	418	437	456	475	494	513	532	551	570	589	608	627
B	315.5	334.5	353.5	372.5	391.5	410.5	429.5	448.5	467.5	486.5	505.5	524.5	543.5	562.5	581.5	600.5	619.5	638.5	657.5	676.5	695.5
C	327.5	346.5	365.5	384.5	403.5	422.5	441.5	460.5	479.5	498.5	517.5	536.5	555.5	574.5	593.5	612.5	631.5	650.5	669.5	688.5	707.5



# Integrated solenoid valve (5/2, 5/3 way)

## 6D/6DW Series

### Installation and application

1. Two types of installation are available, choose appropriate type based on working environment.

#### 1) Panel mount type

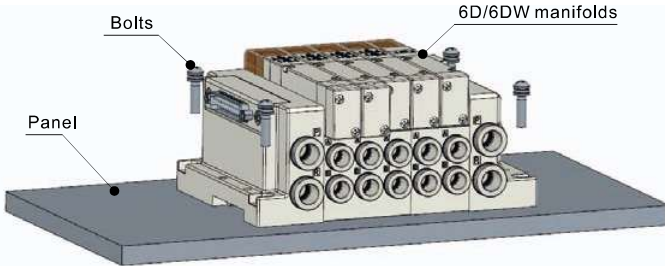

Four counterbore holes for screw bolts, suitable for panel installation.

#### 2) DIN rail mount type

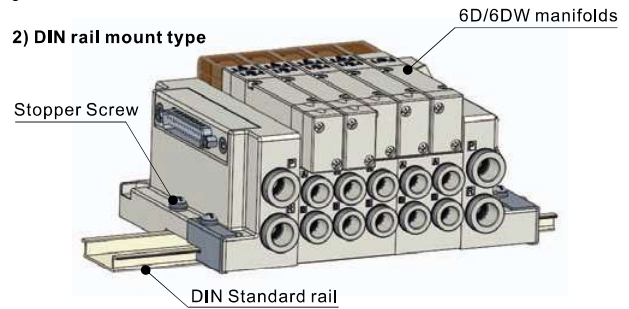

Compatible with standard DIN rail.

6D/6DW manifolds can be fixed at any position of rail by stop screw.

2. P/R ports connection: Please select the appropriate tube diameter according to the following specification table.

Series	Port (P)	Port (R)
6D0500/6DW0500	Φ8	Φ8
6D100/6DW100	Φ10	Φ10
6D200/6DW200	Φ12	Φ12

3. A/B ports connection: Please select the appropriate tube diameter according to the following specification table.

Series\Ports(A/B ports)	Φ4	Φ6	Φ8	Φ10
6D0500/6DW0500	•	•		
6D100/6DW100	•	•	•	
6D200/6DW200			•	•

4. PIN assignment of 6D series:

#### Explanation of 3-12 stations connection pin.

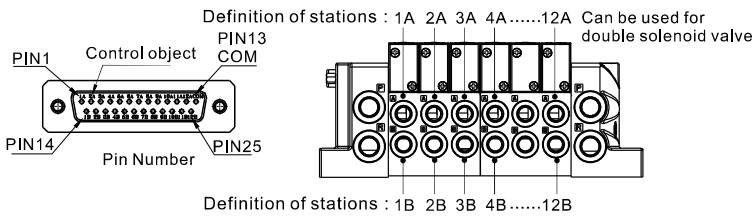

Pin NO.	Polarity		Control object	Pin NO.	Polarity		Control object
	-COM	+COM			-COM	+COM	
1	(+)	(-)	1B	14	(+)	(-)	1A
2	(+)	(-)	2B	15	(+)	(-)	2A
3	(+)	(-)	3B	16	(+)	(-)	3A
4	(+)	(-)	4B	17	(+)	(-)	4A
5	(+)	(-)	5B	18	(+)	(-)	5A
6	(+)	(-)	6B	19	(+)	(-)	6A
7	(+)	(-)	7B	20	(+)	(-)	7A
8	(+)	(-)	8B	21	(+)	(-)	8A
9	(+)	(-)	9B	22	(+)	(-)	9A
10	(+)	(-)	10B	23	(+)	(-)	10A
11	(+)	(-)	11B	24	(+)	(-)	11A
12	(+)	(-)	12B	25	(+)	(-)	12A
13	(-)	(+)	COM	When mounted with single solenoid valves, A signal is empty			

#### Explanation of 13-15 stations connection pin.

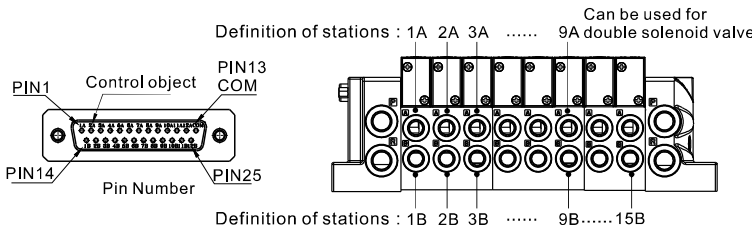

Pin NO.	Polarity		Control object	Pin NO.	Polarity		Control object
	-COM	+COM			-COM	+COM	
1	(+)	(-)	1B	14	(+)	(-)	1A
2	(+)	(-)	2B	15	(+)	(-)	2A
3	(+)	(-)	3B	16	(+)	(-)	3A
4	(+)	(-)	4B	17	(+)	(-)	4A
5	(+)	(-)	5B	18	(+)	(-)	5A
6	(+)	(-)	6B	19	(+)	(-)	6A
7	(+)	(-)	7B	20	(+)	(-)	7A
8	(+)	(-)	8B	21	(+)	(-)	8A
9	(+)	(-)	9B	22	(+)	(-)	9A
10	(+)	(-)	10B	23	(+)	(-)	11B
11	(+)	(-)	12B	24	(+)	(-)	13B
12	(+)	(-)	14B	25	(+)	(-)	15B
13	(-)	(+)	COM	When mounted with single solenoid valves, A signal is empty			

#### Explanation of 16-18 stations connection pin.

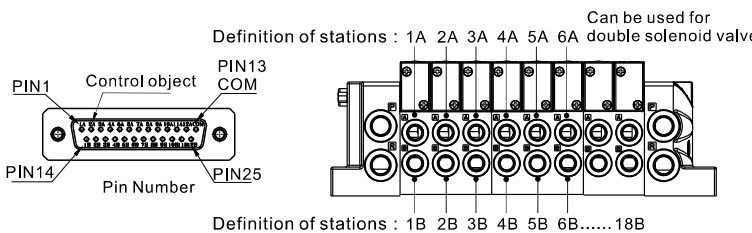

Pin NO.	Polarity		Control object	Pin NO.	Polarity		Control object
	-COM	+COM			-COM	+COM	
1	(+)	(-)	1B	14	(+)	(-)	1A
2	(+)	(-)	2B	15	(+)	(-)	2A
3	(+)	(-)	3B	16	(+)	(-)	3A
4	(+)	(-)	4B	17	(+)	(-)	4A
5	(+)	(-)	5B	18	(+)	(-)	5A
6	(+)	(-)	6B	19	(+)	(-)	6A
7	(+)	(-)	7B	20	(+)	(-)	8B
8	(+)	(-)	9B	21	(+)	(-)	10B
9	(+)	(-)	11B	22	(+)	(-)	12B
10	(+)	(-)	13B	23	(+)	(-)	14B
11	(+)	(-)	15B	24	(+)	(-)	16B
12	(+)	(-)	17B	25	(+)	(-)	18B
13	(-)	(+)	COM	When mounted with single solenoid valves, A signal is empty			

Note: Gauge number of cable connecting to D-Sub pin No.13(COM) must be ≤22AWG

# Integrated solenoid valve (5/2, 5/3 way)

## 6D/6DW Series

### Explanation of 19-21 stations connection pin.

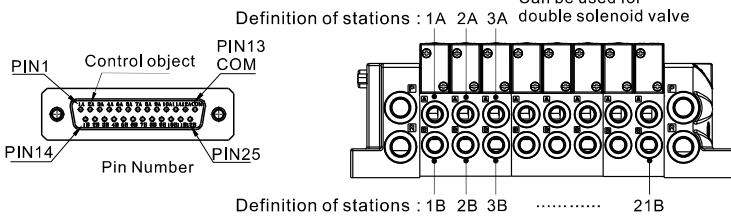

### 5. PIN assignment of 6DW series:

#### Explanation of 13-18 stations connection pin.

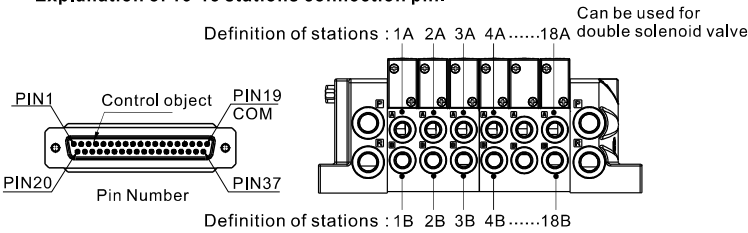

#### Explanation of 19-21 stations connection pin.

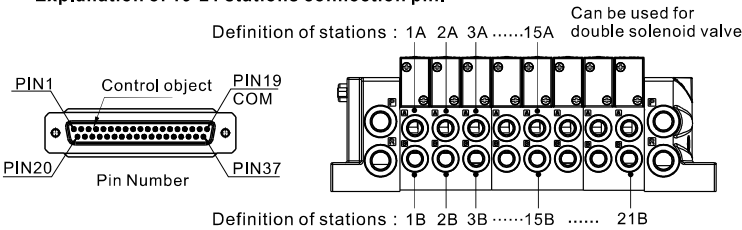

#### Explanation of 22-24 stations connection pin.

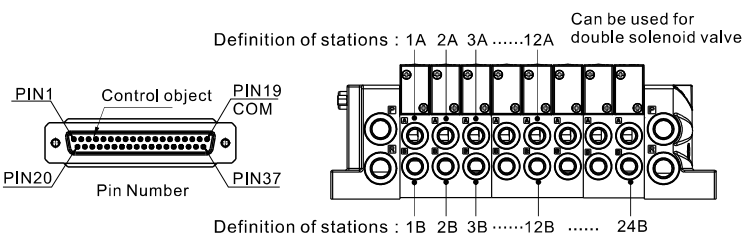

Pin NO.	Polarity		Control object	Pin NO.	Polarity		Control object
	-COM	+COM			-COM	+COM	
1	(+)	(-)	1B	14	(+)	(-)	1A
2	(+)	(-)	2B	15	(+)	(-)	2A
3	(+)	(-)	3B	16	(+)	(-)	3A
4	(+)	(-)	4B	17	(+)	(-)	5B
5	(+)	(-)	6B	18	(+)	(-)	7B
6	(+)	(-)	8B	19	(+)	(-)	9B
7	(+)	(-)	10B	20	(+)	(-)	11B
8	(+)	(-)	12B	21	(+)	(-)	13B
9	(+)	(-)	14B	22	(+)	(-)	15B
10	(+)	(-)	16B	23	(+)	(-)	17B
11	(+)	(-)	18B	24	(+)	(-)	19B
12	(+)	(-)	20B	25	(+)	(-)	21B
13	(-)	(+)	COM	When mounted with single solenoid valves, A signal is empty			

Pin NO.	Polarity		Control object	Pin NO.	Polarity		Control object
	-COM	+COM			-COM	+COM	
1	(+)	(-)	1B	20	(+)	(-)	1A
2	(+)	(-)	2B	21	(+)	(-)	2A
3	(+)	(-)	3B	22	(+)	(-)	3A
4	(+)	(-)	4B	23	(+)	(-)	4A
5	(+)	(-)	5B	24	(+)	(-)	5A
6	(+)	(-)	6B	25	(+)	(-)	6A
7	(+)	(-)	7B	26	(+)	(-)	7A
8	(+)	(-)	8B	27	(+)	(-)	8A
9	(+)	(-)	9B	28	(+)	(-)	9A
10	(+)	(-)	10B	29	(+)	(-)	10A
11	(+)	(-)	11B	30	(+)	(-)	11A
12	(+)	(-)	12B	31	(+)	(-)	12A
13	(+)	(-)	13B	32	(+)	(-)	13A
14	(+)	(-)	14B	33	(+)	(-)	14A
15	(+)	(-)	15B	34	(+)	(-)	15A
16	(+)	(-)	16B	35	(+)	(-)	16A
17	(+)	(-)	17B	36	(+)	(-)	17A
18	(+)	(-)	18B	37	(+)	(-)	18A
19	(-)	(+)	COM	When mounted with single solenoid valves, A signal is empty			

Pin NO.	Polarity		Control object	Pin NO.	Polarity		Control object
	-COM	+COM			-COM	+COM	
1	(+)	(-)	1B	20	(+)	(-)	1A
2	(+)	(-)	2B	21	(+)	(-)	2A
3	(+)	(-)	3B	22	(+)	(-)	3A
4	(+)	(-)	4B	23	(+)	(-)	4A
5	(+)	(-)	5B	24	(+)	(-)	5A
6	(+)	(-)	6B	25	(+)	(-)	6A
7	(+)	(-)	7B	26	(+)	(-)	7A
8	(+)	(-)	8B	27	(+)	(-)	8A
9	(+)	(-)	9B	28	(+)	(-)	9A
10	(+)	(-)	10B	29	(+)	(-)	10A
11	(+)	(-)	11B	30	(+)	(-)	11A
12	(+)	(-)	12B	31	(+)	(-)	12A
13	(+)	(-)	13B	32	(+)	(-)	13A
14	(+)	(-)	14B	33	(+)	(-)	14A
15	(+)	(-)	15B	34	(+)	(-)	15A
16	(+)	(-)	16B	35	(+)	(-)	17B
17	(+)	(-)	18B	36	(+)	(-)	19B
18	(+)	(-)	20B	37	(+)	(-)	21B
19	(-)	(+)	COM	When mounted with single solenoid valves, A signal is empty			

Pin NO.	Polarity		Control object	Pin NO.	Polarity		Control object
	-COM	+COM			-COM	+COM	
1	(+)	(-)	1B	20	(+)	(-)	1A
2	(+)	(-)	2B	21	(+)	(-)	2A
3	(+)	(-)	3B	22	(+)	(-)	3A
4	(+)	(-)	4B	23	(+)	(-)	4A
5	(+)	(-)	5B	24	(+)	(-)	5A
6	(+)	(-)	6B	25	(+)	(-)	6A
7	(+)	(-)	7B	26	(+)	(-)	7A
8	(+)	(-)	8B	27	(+)	(-)	8A
9	(+)	(-)	9B	28	(+)	(-)	9A
10	(+)	(-)	10B	29	(+)	(-)	10A
11	(+)	(-)	11B	30	(+)	(-)	11A
12	(+)	(-)	12B	31	(+)	(-)	12A
13	(+)	(-)	13B	32	(+)	(-)	14B
14	(+)	(-)	15B	33	(+)	(-)	16B
15	(+)	(-)	17B	34	(+)	(-)	18B
16	(+)	(-)	19B	35	(+)	(-)	20B
17	(+)	(-)	21B	36	(+)	(-)	22B
18	(+)	(-)	23B	37	(+)	(-)	24B
19	(-)	(+)	COM	When mounted with single solenoid valves, A signal is empty			

Note: Gauge number of cable connecting to D-Sub pin No.13(19)(COM) must be 22AWG



# Integrated solenoid valve (5/2, 5/3 way)



## 6D/6DW Series

### Explanation of 25-27 stations connection pin.

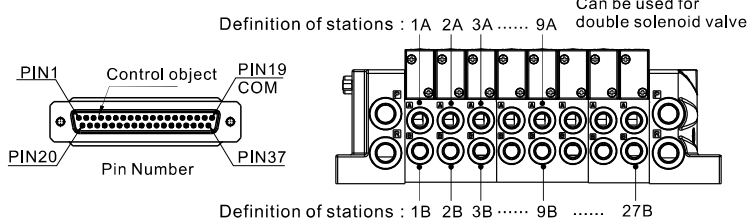

Pin NO.	Polarity		Control object	Pin NO.	Polarity		Control object
	-COM	+COM			-COM	+COM	
1	(+)	(-)	1B	20	(+)	(-)	1A
2	(+)	(-)	2B	21	(+)	(-)	2A
3	(+)	(-)	3B	22	(+)	(-)	3A
4	(+)	(-)	4B	23	(+)	(-)	4A
5	(+)	(-)	5B	24	(+)	(-)	5A
6	(+)	(-)	6B	25	(+)	(-)	6A
7	(+)	(-)	7B	26	(+)	(-)	7A
8	(+)	(-)	8B	27	(+)	(-)	8A
9	(+)	(-)	9B	28	(+)	(-)	9A
10	(+)	(-)	10B	29	(+)	(-)	11B
11	(+)	(-)	12B	30	(+)	(-)	13B
12	(+)	(-)	14B	31	(+)	(-)	15B
13	(+)	(-)	16B	32	(+)	(-)	17B
14	(+)	(-)	18B	33	(+)	(-)	19B
15	(+)	(-)	20B	34	(+)	(-)	21B
16	(+)	(-)	22B	35	(+)	(-)	23B
17	(+)	(-)	24B	36	(+)	(-)	25B
18	(+)	(-)	26B	37	(+)	(-)	27B
19	(-)	(+)	COM	When mounted with single solenoid valves, A signal is empty			

### Explanation of 28-30 stations connection pin.

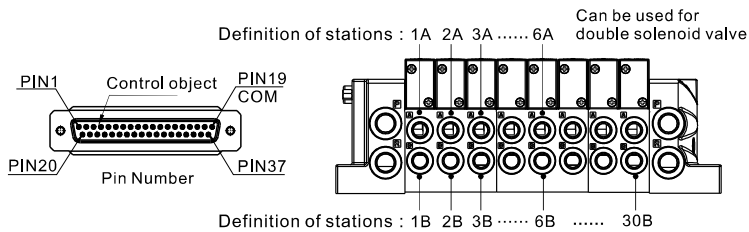

Pin NO.	Polarity		Control object	Pin NO.	Polarity		Control object
	-COM	+COM			-COM	+COM	
1	(+)	(-)	1B	20	(+)	(-)	1A
2	(+)	(-)	2B	21	(+)	(-)	2A
3	(+)	(-)	3B	22	(+)	(-)	3A
4	(+)	(-)	4B	23	(+)	(-)	4A
5	(+)	(-)	5B	24	(+)	(-)	5A
6	(+)	(-)	6B	25	(+)	(-)	6A
7	(+)	(-)	7B	26	(+)	(-)	8B
8	(+)	(-)	9B	27	(+)	(-)	10B
9	(+)	(-)	11B	28	(+)	(-)	12B
10	(+)	(-)	13B	29	(+)	(-)	14B
11	(+)	(-)	15B	30	(+)	(-)	16B
12	(+)	(-)	17B	31	(+)	(-)	18B
13	(+)	(-)	19B	32	(+)	(-)	20B
14	(+)	(-)	21B	33	(+)	(-)	22B
15	(+)	(-)	23B	34	(+)	(-)	24B
16	(+)	(-)	25B	35	(+)	(-)	26B
17	(+)	(-)	27B	36	(+)	(-)	28B
18	(+)	(-)	29B	37	(+)	(-)	30B
19	(-)	(+)	COM	When mounted with single solenoid valves, A signal is empty			

### Explanation of 31-33 stations connection pin.

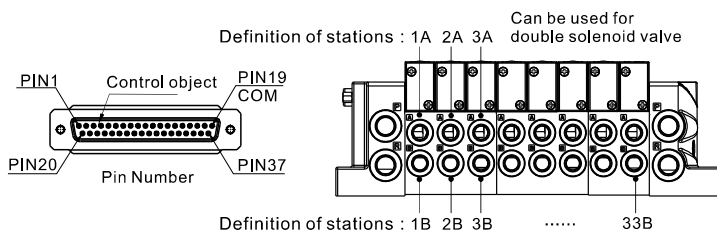

Pin NO.	Polarity		Control object	Pin NO.	Polarity		Control object
	-COM	+COM			-COM	+COM	
1	(+)	(-)	1B	20	(+)	(-)	1A
2	(+)	(-)	2B	21	(+)	(-)	2A
3	(+)	(-)	3B	22	(+)	(-)	3A
4	(+)	(-)	4B	23	(+)	(-)	5B
5	(+)	(-)	6B	24	(+)	(-)	7B
6	(+)	(-)	8B	25	(+)	(-)	9B
7	(+)	(-)	10B	26	(+)	(-)	11B
8	(+)	(-)	12B	27	(+)	(-)	13B
9	(+)	(-)	14B	28	(+)	(-)	15B
10	(+)	(-)	16B	29	(+)	(-)	17B
11	(+)	(-)	18B	30	(+)	(-)	19B
12	(+)	(-)	20B	31	(+)	(-)	21B
13	(+)	(-)	22B	32	(+)	(-)	23B
14	(+)	(-)	24B	33	(+)	(-)	25B
15	(+)	(-)	26B	34	(+)	(-)	27B
16	(+)	(-)	28B	35	(+)	(-)	29B
17	(+)	(-)	30B	36	(+)	(-)	31B
18	(+)	(-)	32B	37	(+)	(-)	33B
19	(-)	(+)	COM	When mounted with single solenoid valves, A signal is empty			

Note: Gauge number of cable connecting to D-Sub pin No.19(COM) must be  $\leq 22$ AWG

6. Flip-able D-SUB portZ: horizontal and vertical side are optional.

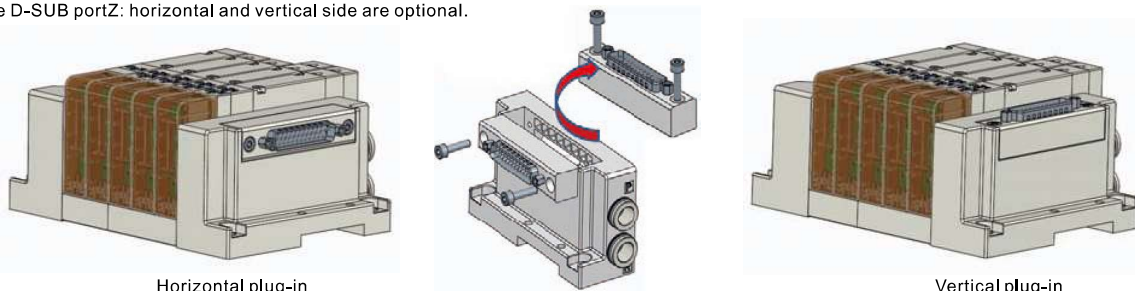

Horizontal plug-in

Vertical plug-in





# 6D/6DW Series Integrated Solenoid Valve—

With Communication Module(5/2,5/3 way)

## Compendium of 6D/6DW Series(with communication module)

Multiple communication modules and protocols are optional

Communication module		Applicable model
No.	Protocols	
1	PROFINET	6D0500/6DW0500 6D100/6DW100 6D200/6DW200
2	EtherNet/IP	
3	EtherCAT	
4	IO-Link	

Network Topology

Daisy-chain wiring

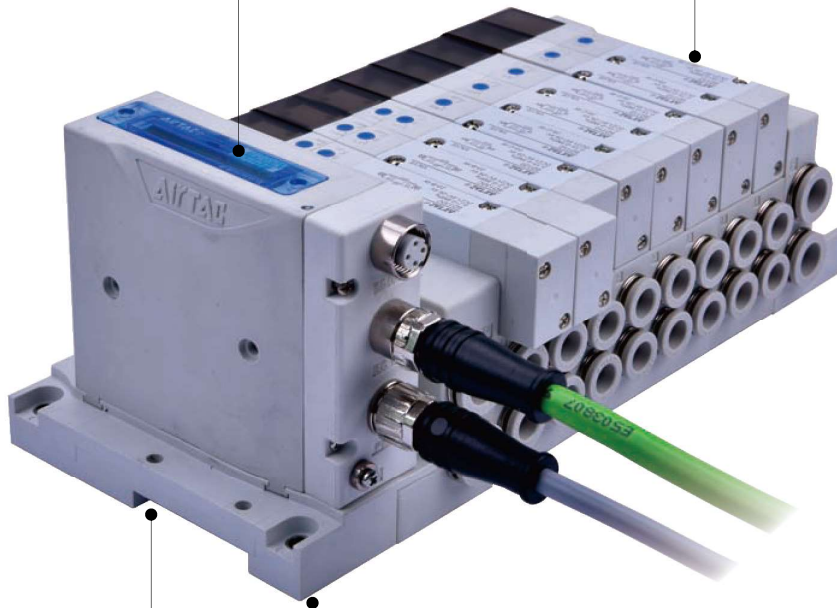
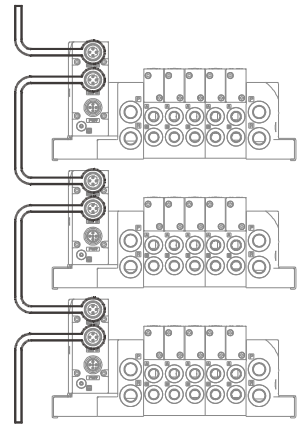

Mounting accessory

No.	Ordering code
1	F-6D0500PN-R2
2	F-6D100PN-R2
3	F-6D200PN-R2

Integration design of communication module

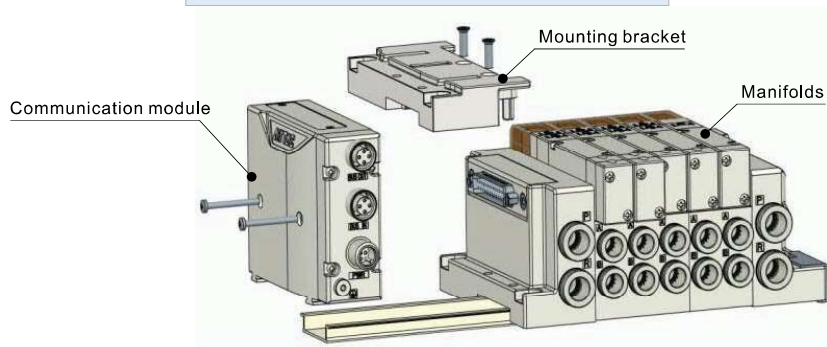

# Integrated solenoid valve (5/2, 5/3 way)



## Communication module



### Specification

Protocol	PROFINET	EtherNet/IP	EtherCAT	IO-Link
Number of outputs	24 outputs/36 outputs			
Communication speed	100Mbps			
Configuration file	GSDML file	EDS file	XML file	COM3/COM2 IODD file
Input power	Voltage DC24V ± 10%			
	Current consumption <100mA			
Voltage output	DC24V ± 10%			
Output type	PNP or NPN			PNP
Power connector	M12 plug 5 pins A-coded			M12 plug 5 pins A-coded
Bus connector	2XM12 socket 4 pins D-coded			
Protection	Dust proof			
Working temperature	-10~60°C			
Working humidity	35~85% RH			
Withstand voltage	AC500V 1min Between terminals and housing			
Insulation resistance	>10MΩ (DC500V), Between terminals and housing			
Communication connection	Daisy-chain wiring			No

### LED indicator

#### Profinet(C-6DPN□)

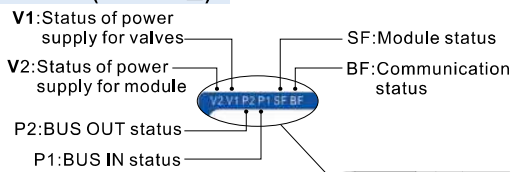

#### EtherNet/IP(C-6DEN□)

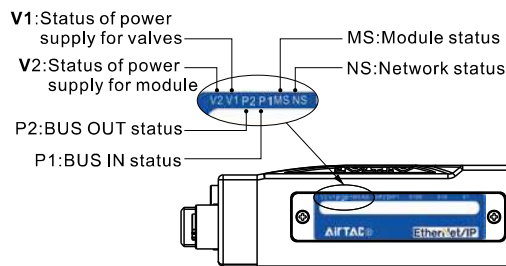

#### EtherCAT(C-6DEA□)

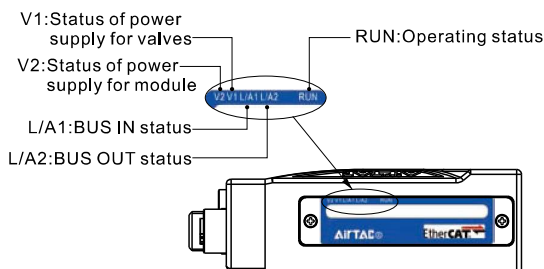

#### IO-Link(C-6DLK□)

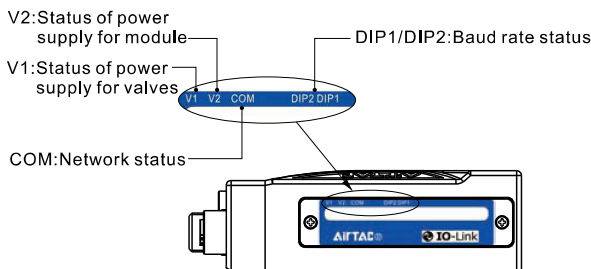

### Construction and function

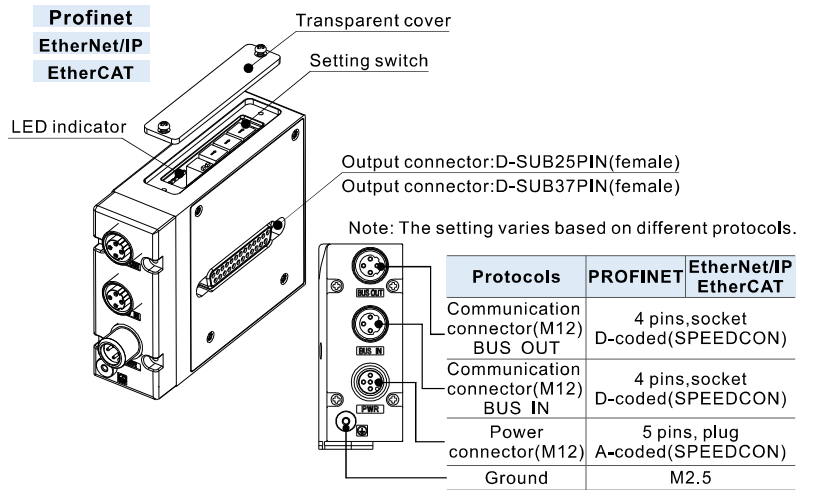

#### IO-Link

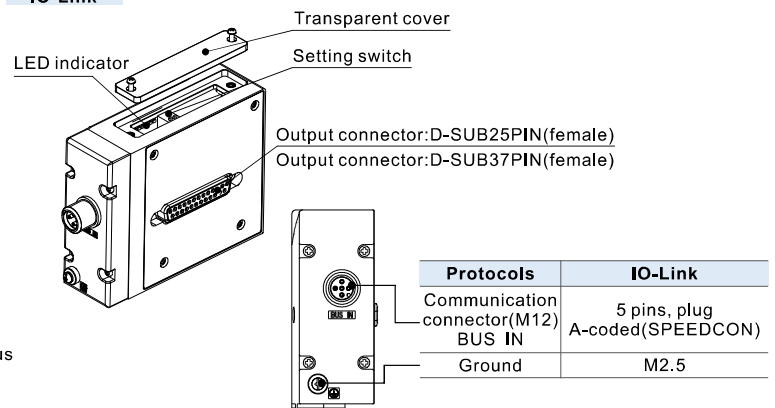

# Integrated solenoid valve (5/2, 5/3 way)

## Communication module

### Ordering Code of communication module

**C-6D PN 1**

① ② ③



① Model	6D : 6D series communication module			
② Protocol type	PN : Profinet	EN : EtherNet/IP	EA : EtherCAT	LK : IO-Link
③ Output type	1 : PNP+24 outputs	2 : NPN+24 outputs	11 : PNP+36 outputs	22 : NPN+36 outputs

Note: IO-Link module doesn't have NPN type.

### Ordering Code of communication cable

**C-M12 RJ PN □ 050**

① ② ③ ④ ⑤

M12 male connector  
D-coded



M12 to M12



RJ45



M12 to RJ45



M12 to wire



① Model	C-M12 : Communication cable (M12 connector)			
② Connector type	Blank : M12 male connectors on both end RJ : M12 male connector+RJ45 terminal		M : M12 female connector+M12 male connector S : M12 female connector+wire	
③ Protocol type	PN : Applicable to Profinet, EtherNet/IP, EtherCAT		LK : Applicable to IO-Link	
④ Cable type	Blank : Cable			
⑤ Cable length	050 : 0.5m	100 : 1m	200 : 2m	300 : 3m 500 : 5m

### Ordering Code of power supply cable

**F-M12 PN □ 150**

① ② ③ ④



① Model	F-M12 : Power supply cable (M12 female connector)		
② Protocol type	PN : Applicable to Profinet, EtherNet/IP, EtherCAT		
③ Cable type	Blank : Cable		
④ Cable length	150 : 1.5m	300 : 3m	500 : 5m

### Ordering Code of mounting bracket

**F-6D0500 PN-R2**

① ② ③ ④



① Model	F : Mounting accessory		
② Code	6D0500 : 6D0500 Series	6D100 : 6D100 Serie	6D200 : 6D200 Serie
③ Protocol type	PN : For 6D module installation		
④ Output type	R2 : Mounting bracket for communication module		

Note: Product comes with mounting screws.

# Integrated solenoid valve (5/2, 5/3 way)



## Communication module

### Dimensions

#### 6D0500 series with communication module

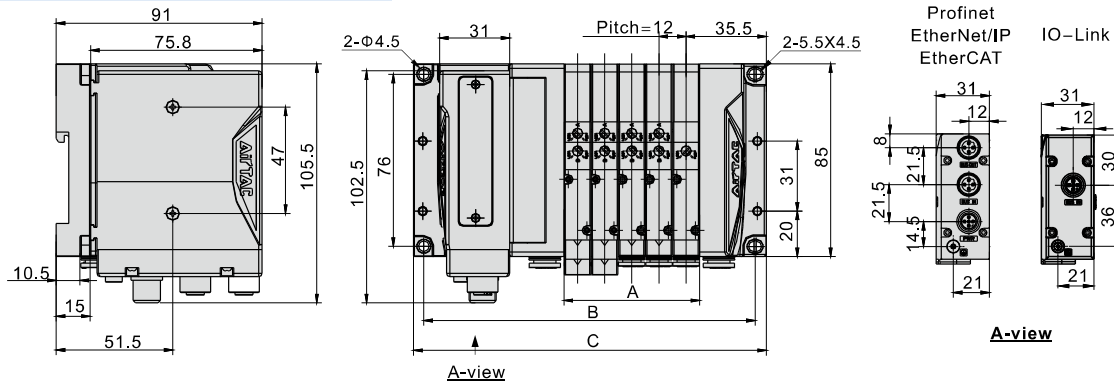

Item\Stations	3F	4F	5F	6F	7F	8F	9F	10F	11F	12F	13F	14F	15F	16F	17F	18F	19F	20F	21F
A	36	48	60	72	84	96	108	120	132	144	156	168	180	192	204	216	228	240	252
B	122.5	134.5	146.5	158.5	170.5	182.5	194.5	206.5	218.5	230.5	242.5	254.5	266.5	278.5	290.5	302.5	314.5	326.5	338.5
C	132	144	156	168	180	192	204	216	228	240	252	264	276	288	300	312	324	336	348

#### 6D100 series with communication module

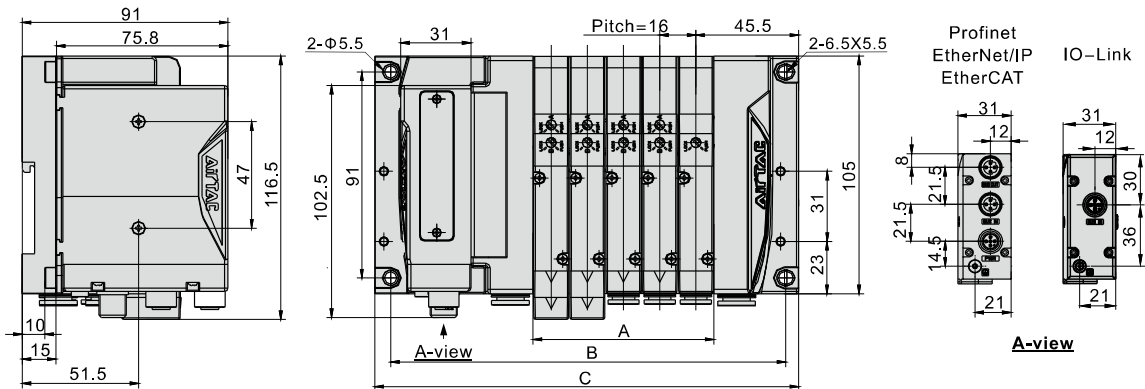

Item\Stations	3F	4F	5F	6F	7F	8F	9F	10F	11F	12F	13F	14F	15F	16F	17F	18F	19F	20F	21F
A	48	64	80	96	112	128	144	160	176	192	208	224	240	256	272	288	304	320	336
B	142.5	158.5	174.5	190.5	206.5	222.5	238.5	254.5	270.5	286.5	302.5	318.5	334.5	350.5	366.5	382.5	398.5	414.5	430.5
C	155.5	171.5	187.5	203.5	219.5	235.5	251.5	267.5	283.5	299.5	315.5	331.5	347.5	363.5	379.5	395.5	411.5	427.5	443.5

#### 6D200 series with communication module

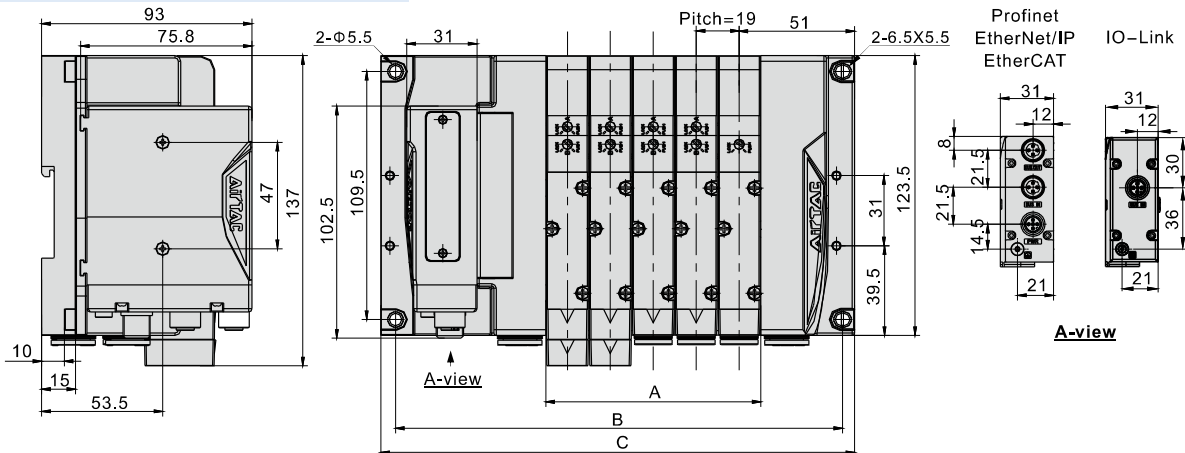

Item\Stations	3F	4F	5F	6F	7F	8F	9F	10F	11F	12F	13F	14F	15F	16F	17F	18F	19F	20F	21F
A	57	76	95	114	133	152	171	190	209	228	247	266	285	304	323	342	361	380	399
B	159.5	178.5	197.5	216.5	235.5	254.5	273.5	292.5	311.5	330.5	349.5	368.5	387.5	406.5	425.5	444.5	463.5	482.5	501.5
C	171.5	190.5	209.5	228.5	247.5	266.5	285.5	304.5	323.5	342.5	361.5	380.5	399.5	418.5	437.5	456.5	475.5	494.5	513.5



# Integrated solenoid valve (5/2, 5/3 way)



## Communication module

### 6DW0500 series with communication module

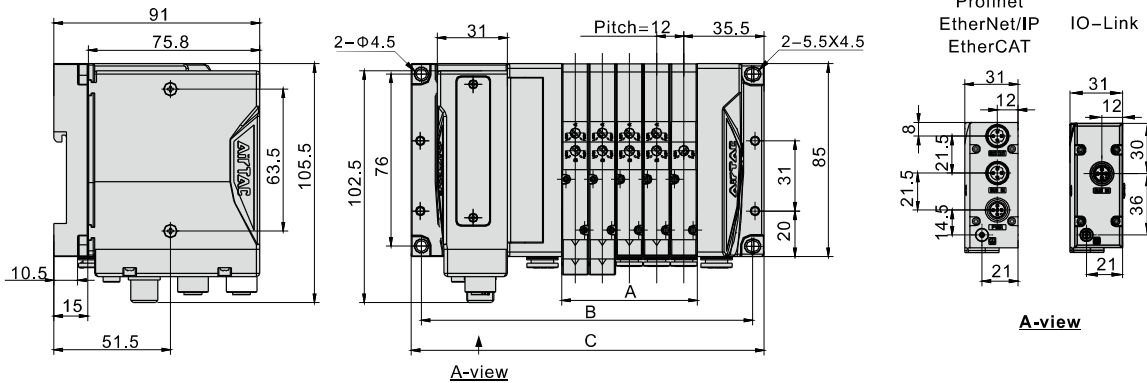

Item\Stations	13F	14F	15F	16F	17F	18F	19F	20F	21F	22F	23F	24F	25F	26F	27F	28F	29F	30F	31F	32F	33F
A	156	168	180	192	204	216	228	240	252	264	276	288	300	312	324	336	348	360	272	384	396
B	242.5	254.5	266.5	278.5	290.5	302.5	314.5	326.5	338.5	350.5	362.5	374.5	386.5	398.5	410.5	422.5	434.5	446.5	458.5	470.5	482.5
C	252	264	276	288	300	312	324	336	348	360	372	384	396	408	420	432	444	456	468	480	492

### 6DW100 series with communication module

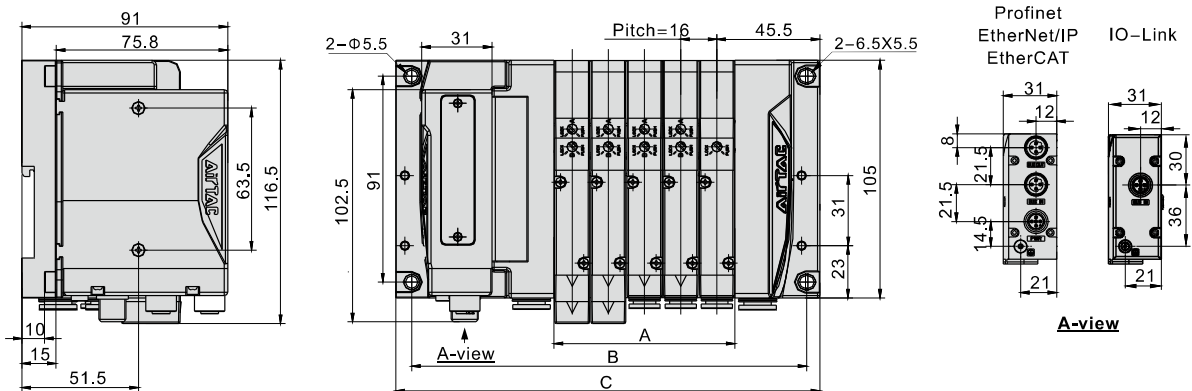

Item\Stations	13F	14F	15F	16F	17F	18F	19F	20F	21F	22F	23F	24F	25F	26F	27F	28F	29F	30F	31F	32F	33F
A	208	224	240	256	272	288	304	320	336	352	368	384	400	416	432	448	464	480	496	512	528
B	302.5	318.5	334.5	350.5	366.5	382.5	398.5	414.5	430.5	446.5	462.5	478.5	494.5	510.5	526.5	542.5	558.5	574.5	590.5	606.5	622.5
C	315.5	331.5	347.5	363.5	379.5	395.5	411.5	427.5	443.5	459.5	475.5	491.5	507.5	523.5	539.5	555.5	571.5	587.5	603.5	619.5	635.5

### 6DW200 series with communication module

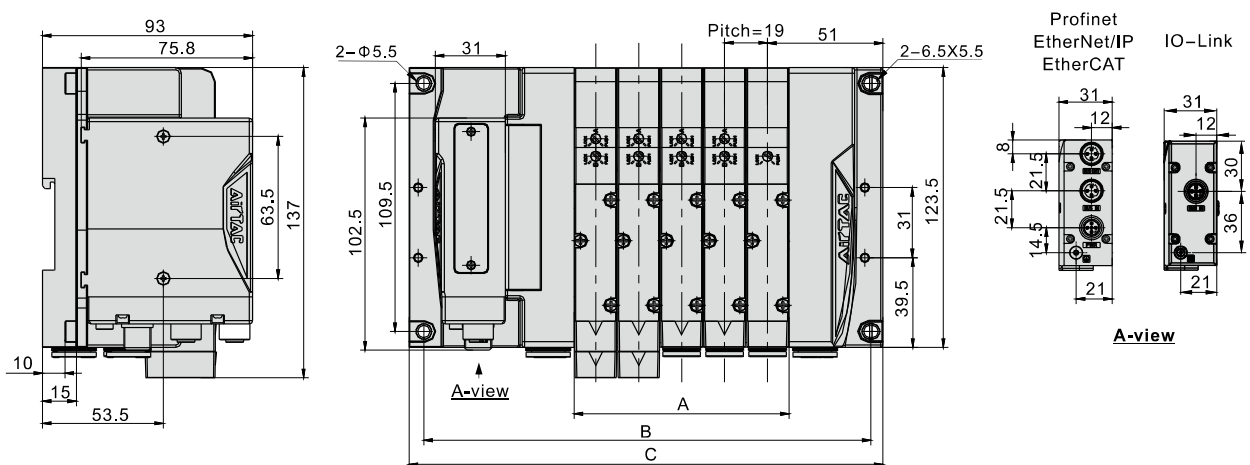

Item\Stations	13F	14F	15F	16F	17F	18F	19F	20F	21F	22F	23F	24F	25F	26F	27F	28F	29F	30F	31F	32F	33F
A	247	266	285	304	323	342	361	380	399	418	437	456	475	494	513	532	551	570	589	608	627
B	349.5	368.5	387.5	406.5	425.5	444.5	463.5	482.5	501.5	520.5	539.5	558.5	577.5	596.5	615.5	634.5	653.5	672.5	691.5	710.5	729.5
C	361.5	380.5	399.5	418.5	437.5	456.5	475.5	494.5	513.5	532.5	551.5	570.5	589.5	608.5	627.5	646.5	665.5	684.5	703.5	722.5	741.5



# Integrated solenoid valve (5/2, 5/3 way)

## Communication module

### Communication cable M12 to M12

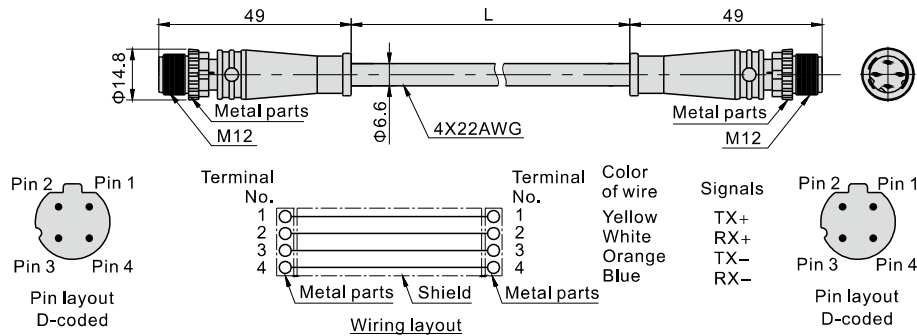

### Communication cable M12 to RJ45

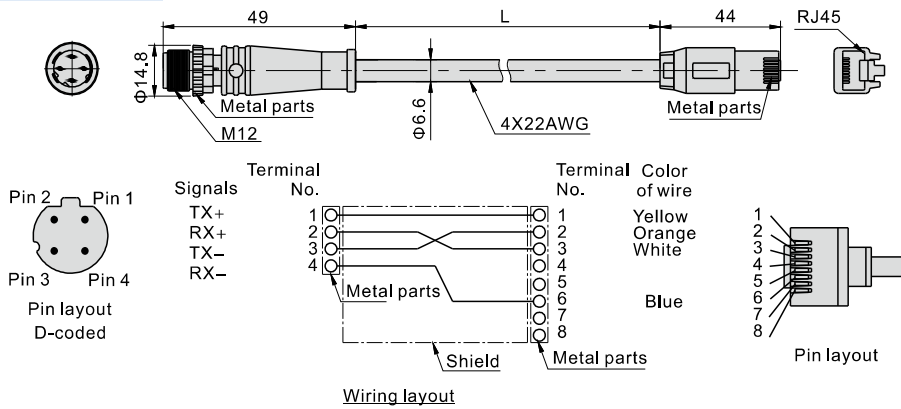

### Communication cable M12 to M12/M12 to wires(IO-Link)

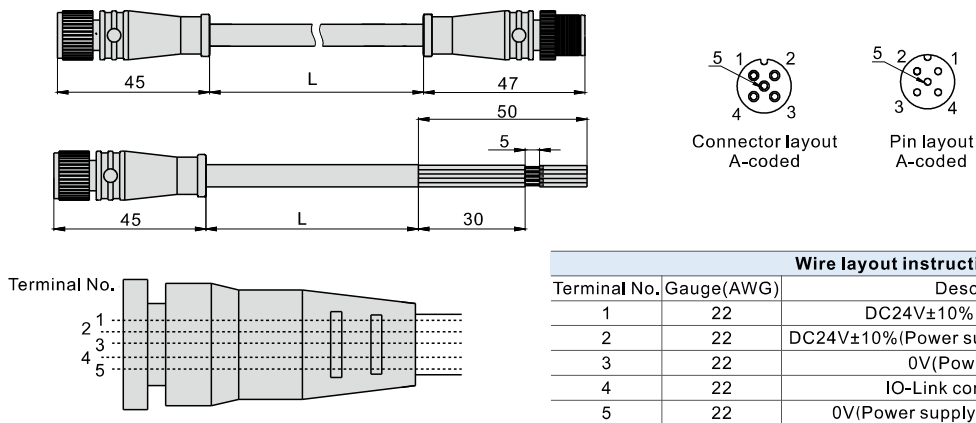

### Power supply cable M12 to wires

