

Solenoid valve(3/2 way)



6TV Series



Specification

Model	6TV0510	6TV0520	6TV110	6TV120
Port size [Note1]	In=Out=Exh=M5		In=Out=Exh=M5(or=1/8")	
Orifice size(Cv)[Note4]	M5:3.4mm ² (0.2)		06 : 8.9mm ² (0.52)	
Weight (g)	28	43	52	67
Model	6TV210	6TV220	6TV310	6TV320
Port size [Note1]	06 : In=Out=Exh=1/8"		In=Out=3/8" Exh=1/4"	
Orifice size(Cv)[Note4]	08 : 15.4mm ² (0.91)		10:38.4mm ² (2.26)	
Weight (g)	90	105	180	215
Fluid	Air(to be filtered by 40μm filter element)			
Acting	Internal pilot			
Operating pressure	0.15~0.8MPa(21~114psi)			
Proof pressure	1.2MPa(175psi)			
Temperature	-20~70°C			
Material of body	Aluminum alloy			
Lubrication [Note2]	Not required			
Exhaust type of pilot valve	Main valve and pilot valve concentrated exhaust			
Max.frequency [Note3]	5 cycle/sec			

[Note1] PT thread, G thread and NPT thread are available.

[Note2] Once lubricated air is used, continue with same medium to optimise valve life span. Lubricants like ISO VG32 or equivalent are recommended.

[Note3] The maximum actuation frequency is in the no-load state.

[Note4] Equivalent orifice S and Cv are all calculated from the flow rate data.

Symbol

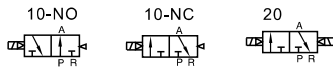

Product feature

1. Electrical entry is terminal, horizontal and vertical insertion can freely switch.
2. Inner exhaust structure to collect pilot airflow, and then exhaust intensively from R port.
3. The body is extruded by aluminum alloy, and the inner hole is specially processed to increase the flow rate.
4. Threaded type and quick connector type are optional, and can integrate manifold to form valve group to save space.

Ordering code

6TV 1 10 06 NC B 050 □



6TV : Solenoid valve (3/2 way)			
① Model	6TV : Solenoid valve (3/2 way)		
② Code	05: 0500 Series	1: 100 Series	2: 200 Series 3: 300 Series
③ Valve type	10: Single solenoid 20 : Double solenoid		
④ Port size	M5: M5	M5: M5	06: 1/8" 06: 1/8" 08: 1/4" 10: 3/8"
⑤ Acting type	NC: Normally closed NO: Normally opened [Note : Double solenoid no this code]		
⑥ Voltage	A: AC220V B: DC24V C: AC110V F: DC12V		
⑦ Wire length	050: 0.5m 200: 2.0m		
⑧ Thread type	Blank: PT Thread/ G: G Thread / T: NPT Thread		

Flow chart

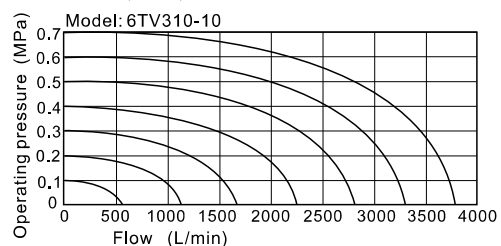
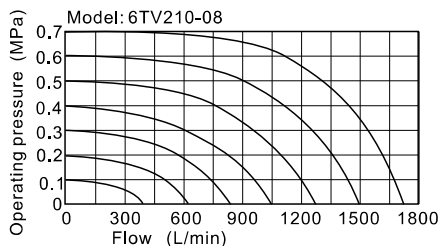
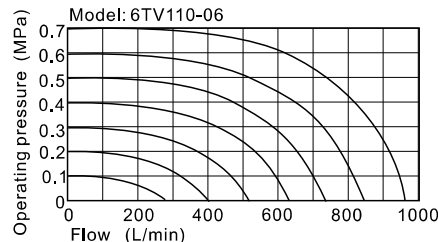
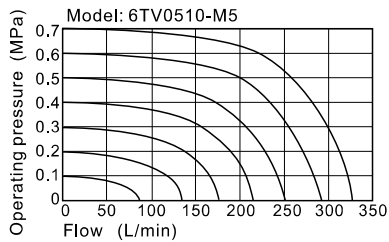

The data in flow rate chart are obtained from AirTAC lab.



Solenoid valve(3/2 way)

6TV Series

Inner structure

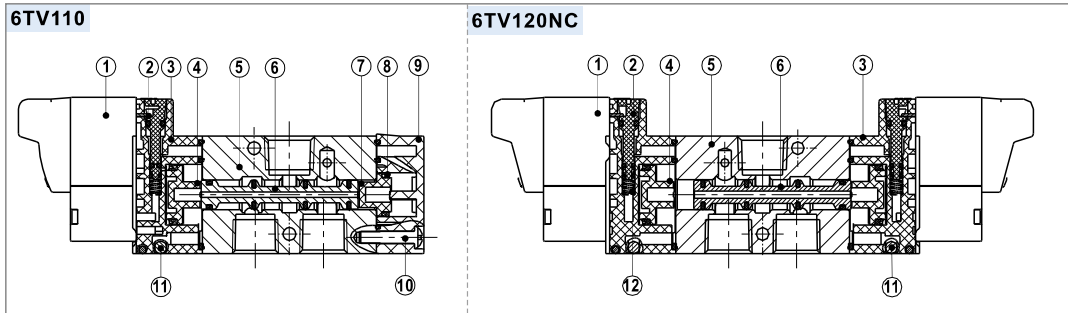

No.	Item
1	Pilot valve
2	Manual override
3	Pilot kit
4	Big piston
5	Body
6	Spool
7	Small piston
8	Gasket
9	Bottom cover
10	Bolt
11	Steel ball
12	Spring

Dimensions

6TV0510
6TV110
6TV210
6TV310

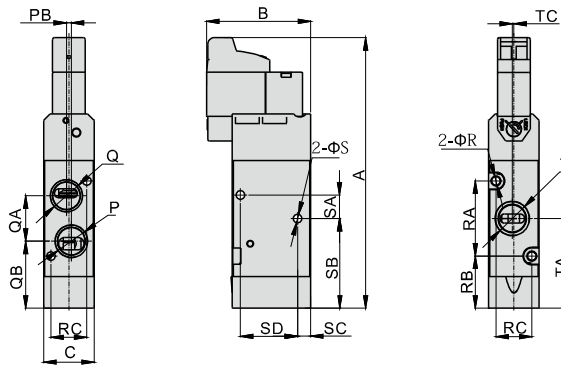

Model\Item	A	B	C	P	PB	Q	QA	QB	R	RA	RB	RC	S	SA	SB	SC	SD	T	TA	TC
6TV0510M5	64.5	30.5	10.6	M5X0.8	1	M5X0.8	9.5	13.5	2.1	14	11.5	7.5	-	-	-	-	-	M5X0.8	18.5	0.5
6TV110M5	83	32	15.5	M5X0.8	-	M5X0.8	14	20.5	2.6	23	16	11	Φ2.6	7.2	27.5	4	17.5	M5X0.8	27.5	-
6TV11006	83	32	15.5	1/8"	1.5	1/8"	14	20.5	2.6	23	16	11	Φ2.6	7.2	27.5	4	17.5	1/8"	27.5	0.5
6TV21006	97	33.5	18.5	1/8"	-	1/8"	18	25.5	3.2	33	18	13.5	Φ3.2	12	34.5	7	21	1/8"	34.5	-
6TV21008	97	33.5	18.5	1/4"	-	1/8"	18	25.5	3.2	33	18	13.5	Φ3.2	12	34.5	7	21	1/4"	34.5	1
6TV31010	116.5	46	23.5	3/8"	-	1/4"	28	29.5	3.2	43	22	18.4	Φ4.3	15	58.5	8	31	3/8"	43.5	-

[Note]: 6TV0510 type no through hole "S" on the side.

6TV0520
6TV120
6TV220
6TV320

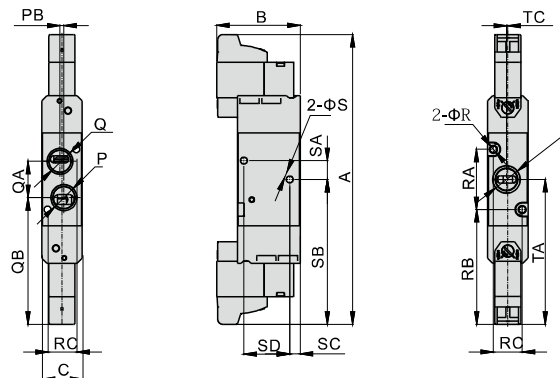

Model\Item	A	B	C	P	PB	Q	QA	QB	R	RA	RB	RC	S	SA	SB	SC	SD	T	TA	TC
6TV0520M5	93	30.5	10.6	M5X0.8	1	M5X0.8	9.5	41.5	2.1	14	39.5	7.5	-	-	-	-	-	M5X0.8	18.5	0.5
6TV120M5	110.5	32	15.5	M5X0.8	-	M5X0.8	14	48.5	2.6	23	44	11	Φ2.6	7.2	55.5	4	17.5	M5X0.8	27.5	-
6TV12006	110.5	32	15.5	1/8"	1.5	1/8"	14	48.5	2.6	23	44	11	Φ2.6	7.2	55.5	4	17.5	1/8"	27.5	0.5
6TV22006	125	33.5	18.5	1/8"	-	1/8"	18	53.5	3.2	33	46	13.5	Φ3.2	12	62.5	7	21	1/8"	34.5	-
6TV22008	125	33.5	18.5	1/4"	-	1/8"	18	53.5	3.2	33	46	13.5	Φ3.2	12	62.5	7	21	1/4"	34.5	1
6TV32010	146	46	23.5	3/8"	-	1/4"	28	59	3.2	43	51.5	18.4	Φ4.3	15	73	8	31	3/8"	43.5	-

[Note]: 6TV0520 type no through hole "S" on the side.

Solenoid valve(Accessories)



Manifold for 6TV Series



Specification

Item\Manifold Model	6TV0500M	6TV100M	6TV200M	6TV300M
Fluid	Air(to be filtered by 40µm filter element)			
Temperature °C	-20~70			
Adaptable valve's series	6TV0500 Series	6TV100 Series	6TV200 Series	6TV300 Series

Product feature

1. It is available to integrate the direction control valves of the same series to form valve group to save space and cost.
2. It is easy to examine when there are faults owing to the unified air intake and exhaust and unified wiring.
3. Flexible combination and strong expansion capability can make any combination or expansion of the numbers of direction control valves that are connected.

Ordering code

6TV100M 5F □ Ordering code for manifold



① Model	6TV0500M: 6TV0500 Series manifold	6TV100M: 6TV100 Series manifold	6TV200M: 6TV200 Series manifold	6TV300M: 6TV300 Series manifold
② Number of stations	1F: 1 Station 2F: 2 Station 3F: 3 Station 20F: 20 Station			
③ Thread type	Blank: PT / G: G Thread / T: NPT Thread			

P-6TV100M - R2 Ordering code for blank plate



① Model	6TV0500M: 6TV0500 Series manifold	6TV100M: 6TV100 Series manifold	6TV200M: 6TV200 Series manifold	6TV300M: 6TV300 Series manifold
② Code	R2: Blank plate for manifold			

[Note] 1. Manifold kits contains manifold, seal and screw; 2. Blank plate kits contains blank plate and screw.

Dimensions

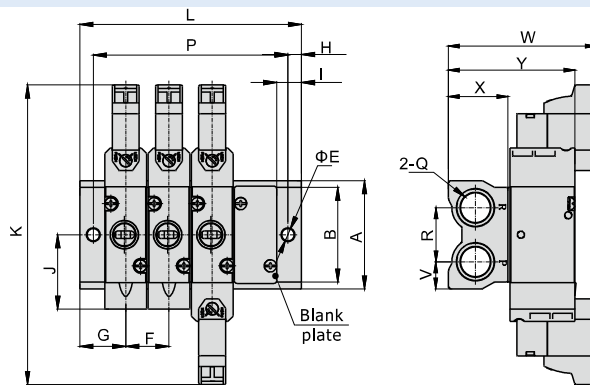

Model\Item	A	B	E	F	G	H	I	J	K	Q	R	V	W	X	Y
6TV0500M	33	26	4.5	11	15	5	9.5	18.5	93	1/8"	16.5	8.5	48.5	17	36
6TV100M	40	35	4.5	16	17	5	9	27.5	110.5	1/4"	20	10	54.5	22	47
6TV200M	48	44	4.5	19	18.5	5	9	34.5	125	1/4"	24	12	58	23.5	57
6TV300M	60	54	4.5	24	24	5	12.5	43.5	146	3/8"	32	14	74	27	-

Model\Item	L																			
	1F	2F	3F	4F	5F	6F	7F	8F	9F	10F	11F	12F	13F	14F	15F	16F	17F	18F	19F	20F
6TV0500M	30	41	52	63	74	85	96	107	118	129	140	151	162	173	184	195	206	217	228	239
6TV100M	34	50	66	82	98	114	130	146	162	178	194	210	226	242	258	274	290	306	322	338
6TV200M	37	56	75	94	113	132	151	170	189	208	227	246	265	284	303	322	341	360	379	398
6TV300M	48	72	96	120	144	168	192	216	240	264	288	312	336	360	384	408	432	456	480	504

Model\Item	P																			
	1F	2F	3F	4F	5F	6F	7F	8F	9F	10F	11F	12F	13F	14F	15F	16F	17F	18F	19F	20F
6TV0500M	20	31	42	53	64	75	86	97	108	119	120	141	152	163	174	185	196	207	218	229
6TV100M	24	40	56	72	88	104	120	136	152	168	184	200	216	232	248	264	280	296	312	328
6TV200M	27	46	65	84	103	122	141	160	179	198	217	236	255	274	293	312	331	350	369	388
6TV300M	38	62	86	110	134	158	182	206	230	254	278	302	326	350	374	398	422	446	470	494

