

# Preparation unit—GP Series

## GPFR Series Precision Filter & Regulator

### Symbol

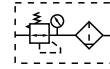

### Product feature

1. Circular square pressure gauge which with clip and magnifier is used to save installation space.
2. The pressed-in self-locking mechanism can prevent the abnormal movement of the set pressure caused by external interfere.
3. Balanced design is adopted for the pressure adjustment mechanism.
4. Unique diversion structure spins the air flowing through to effectively separate the liquid from the air and reliably filter the solid grain.
5. The filtering grade includes 0.3 $\mu$ m and 0.01 $\mu$ m (optional).
6. Two drain types are available: semi-auto drain and automatic drain.
7. Three material of bowl are available: PC, Nylon and metal.
8. The bracket can be selected for installation.

### Specification

Model	GPFR200-06	GPFR200-08	GPFR300-08	GPFR300-10	GPFR400-10	GPFR400-15
Fluid	Air					
Port size [Note1]	1/8"	1/4"	1/4"	3/8"	3/8"	1/2"
Filtering grade	0.3 $\mu$ m or 0.01 $\mu$ m					
Pressure range	0.15~0.9MPa(20~130psi)					
Max. pressure	1.0MPa(145psi)					
Proof pressure	1.5MPa(215psi)					
Temperature range	-5~70°C(Unfreeze)					
Rated flow capacity [Note2]	M	150L/min		330L/min		820L/min
	D	90L/min		180L/min		450L/min
Capacity of drain bowl		25CC		60CC		100CC
Weight		310g		500g		910g

[Note1] G thread, NPT thread and PT thread are available.

[Note2] Conditions: inlet pressure 0.7MPa, outlet pressure 0.5MPa. The rated flow varies with the inlet pressure. If the flow exceeds the rated flow, oil will flow to the secondary side. Please note.

### Ordering code

GPFR300 □ 10 □ S □ □ M G

① ② ③ ④ ⑤ ⑥ ⑦ ⑧ ⑨

① Model	② Material of bowl	③ Port size	④ Drain type	⑤ Type code	⑥ Accessories	⑦ Pressure gauge	⑧ Filtering grade	⑨ Thread type
GPFR200:GP200 Series Precision filter-regulator	Blank: PC N: Nylon C: Metal	06: 1/8" 08: 1/4"	Blank: Semi-auto drain +Manual drain A: Automatic drain	S: Standard	Blank: Bracket J: No bracket	Blank: Circular with clip N: No pressure gauge [Note2]	M: 0.3 $\mu$ m D: 0.01 $\mu$ m	Blank: PT (MPa/psi)
GPFR300:GP300 Series Precision filter-regulator		08: 1/4" 10: 3/8"		L: Lower pressure [Note1]				G: G(bar/MPa)
GPFR400:GP400 Series Precision filter-regulator		10: 3/8" 15: 1/2"						T: NPT(psi/bar)

[Note1] The maximum work pressure of lower pressure type is 58psi(0.4MPa). [Note2] Please refer to page 246 for details of sealing plate Installation.

# Preparation unit—GP Series

## GPFR Series Precision Filter & Regulator



### Inner structure

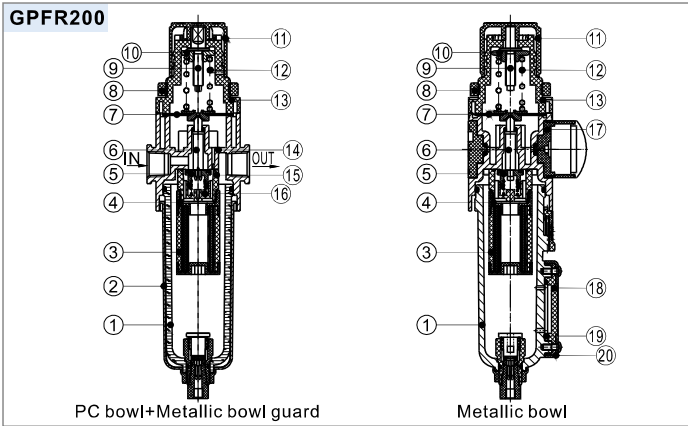

No.	Item	Material
1	Drain bowl	PC\nylon\aluminium alloy
2	Meter cover	SPCC
3	Filter core	Polymer materials
4	Gasket	NBR
5	Adjusting plug	Aluminum alloy & Rubber
6	Adjusting spool	POM
7	Diaphragm	NBR
8	Fixation ring cap	POM
9	Adjusting spindle	08A
10	Regulator nut	Steel
11	Pressure knob	POM
12	Spring	SWPB
13	Adjusting seat	POM
14	Body of filter-regulator	Aluminium alloy
15	Gas distribution	POM
16	Spring	SWPB
17	Gauge	-
18	Liquid meter inside cover	PC
19	Liquid meter seal	NBR
20	Liquid meter cover	SPCC

### Dimensions

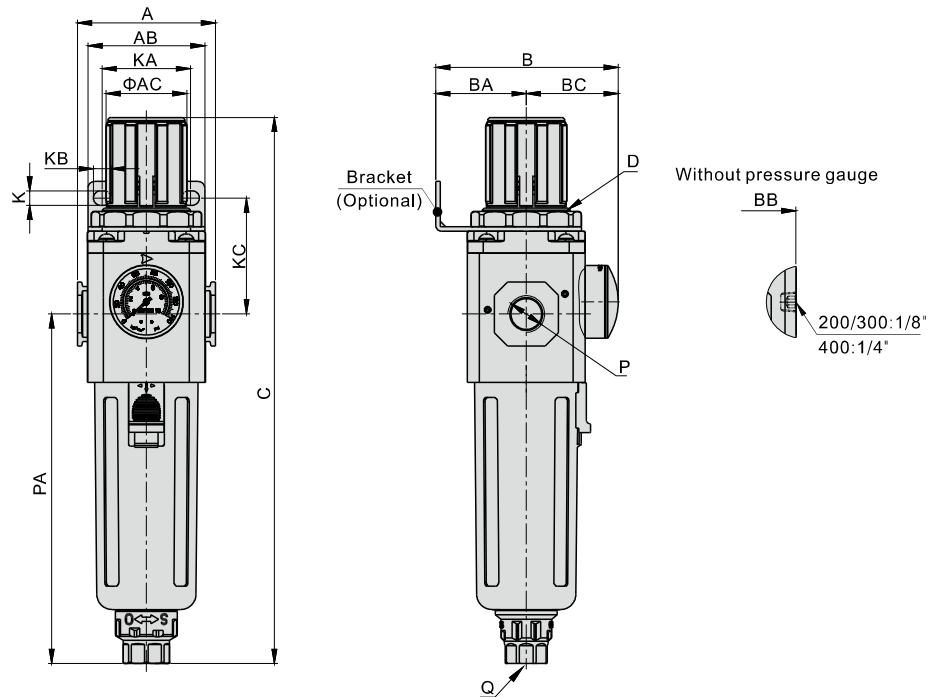

Model\Item	A	AB	AC	B	BA	BB	BC	C	D	K	KA	KB	KC	P	PA	Q
GPFR200-06	52.5	55	31	69	30	51.5	39	192.5	M33x1.5	5.4	34	15.4	52	1/8"	120	M5X0.8
GPFR200-08	52.5	55	31	69	30	51.5	39	192.5	M33x1.5	5.4	34	15.4	52	1/4"	120	M5X0.8
GPFR300-08	62.5	53	38	82.5	41	67.5	41.5	247	M40x1.5	6.5	40	8	52.5	1/4"	158	G1/4
GPFR300-10	62.5	53	38	82.5	41	67.5	41.5	247	M40x1.5	6.5	40	8	52.5	3/8"	158	G1/4
GPFR400-10	80	72	52	99	50	84	49	285.5	M55x2.0	8.5	55	11	57	3/8"	177.5	G1/4
GPFR400-15	80	72	52	99	50	84	49	285.5	M55x2.0	8.5	55	11	57	1/2"	177.5	G1/4



# Preparation unit—GP Series

## GPFR Series Precision Filter & Regulator

### Pressure chart

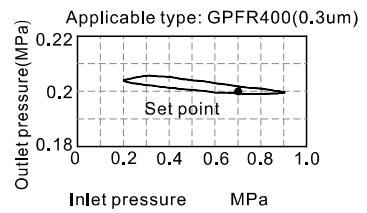
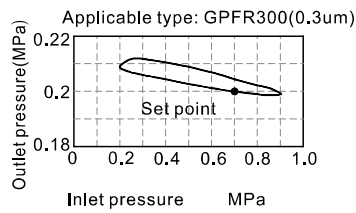
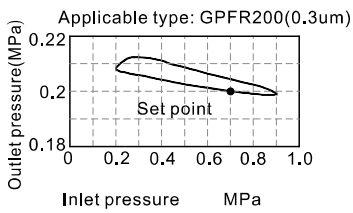
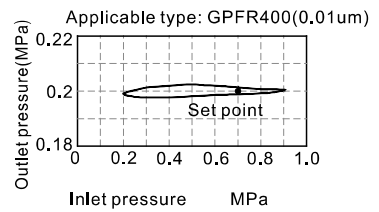
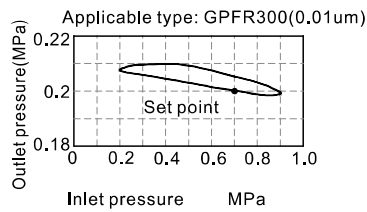
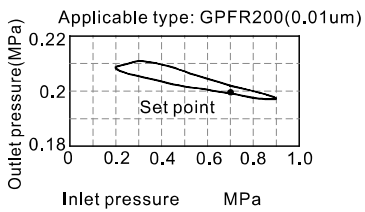

### Flow chart

