



# Standard cylinder—JSI Series

## Compendium of JSI Series

**JSI Standard cylinder**  
Bore size: 32, 40, 50, 63, 80, 100, 125

**Adjustable air buffer**  
With adjustable air buffer on the front and back cover

**No tie rod cylinder**  
The cylinder barrel is aluminum profile with hard anodizing treatment.

**Convenient and fast fix sensor switch**  
With sensor switch groove on the two sides of body, the counterpart sensor switch type is: CMSE \ DMSE.

**Four kinds of cylinder joints**

- I Knuckle
- Y Knuckle
- Floating Joint
- Universal Joint

**Multi-mounting accessories**

- LB
- FA
- FB
- CA
- CB
- CR
- TC
- TCM1
- TCM2

**Multi-type cylinder**

- JSI: Double acting type
- JSID: Double rod type
- JSIJ: Adjustable stroke type

### Criteria for selection: Cylinder thrust

Unit : Newton(N)

Bore size	Rod size	Acting type	Pressure area(mm <sup>2</sup> )	Operating pressure(MPa)										
				0.1	0.2	0.3	0.4	0.5	0.6	0.7	0.8	0.9		
32	12	Double acting	804	80.4	160.8	241.2	321.6	402.0	482.4	562.8	643.2	723.6		
		Push side	690	69.0	138.0	207.0	276.0	345.0	414.0	483.0	552.0	621.0		
40	16	Double acting	1256	125.6	251.2	376.8	502.4	628.0	753.6	879.2	1004.8	1130.4		
		Push side	1055	105.5	211.0	316.5	422.0	527.5	633.0	738.5	844.0	949.5		
50	20	Double acting	1963	196.3	392.6	588.9	785.2	981.5	1177.8	1374.1	1570.4	1766.7		
		Push side	1649	164.9	329.8	494.7	659.6	824.5	989.4	1154.3	1319.2	1484.1		
63	20	Double acting	3117	311.7	623.4	935.1	1246.8	1558.5	1870.2	2181.9	2493.6	2805.3		
		Push side	2803	280.3	560.6	840.9	1121.2	1401.5	1681.8	1962.1	2242.4	2522.7		
80	25	Double acting	5026	502.6	1005.2	1507.8	2010.4	2513.0	3015.6	3518.2	4020.8	4523.4		
		Push side	4536	453.6	907.2	1360.8	1814.4	2268.0	2721.6	3175.2	3628.8	4082.4		
100	32	Double acting	7853	785.3	1570.6	2355.9	3141.2	3926.5	4711.8	5497.1	6282.4	7067.7		
		Push side	7147	714.7	1429.4	2144.1	2858.9	3573.6	4288.3	5003.0	5717.7	6432.4		
125	32	Double acting	12272	1227.2	2454.4	3681.6	4908.8	6136.0	7363.2	8590.4	9817.6	11044.8		
		Push side	11468	1146.8	2293.6	3440.4	4587.2	5734.0	6880.8	8027.6	9174.4	10321.2		

### Installation and application



- When load changes in the work, the cylinder with abundant output capacity shall be selected.
- Relative cylinder with high temperature resistance or corrosion resistance shall be chosen under the condition of high temperature or corrosion.
- Necessary protection measure shall be taken in the environment with higher humidity, much dust or water drops, oil dust and welding dregs.
- Dirty substances in the pipe must be eliminated before cylinder is connected with pipeline to prevent the entrance of particles into the cylinder.
- The medium used by cylinder shall be filtered to 40μm or below.
- Anti-freezing measure shall be adopted under low temperature environment to prevent moisture freezing.
- The cylinder shall be carried out test run without load before application. Prior to run, buffer shall be turned to the minimum and gradually released to avoid the damage on cylinder caused by excessive impact.
- The cylinder shall avoid the influence of side load in operation to maintain the normal work of cylinder and extend the service life.
- If the cylinder is dismantled and stored for a long time, please conduct anti-rust treatment to the surface. Anti-dust caps shall be added in air inlet and outlet ports.



# Standard cylinder

## JSI Series



### Symbol

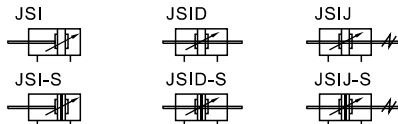

### Specification

Bore size(mm)	32	40	50	63	80	100	125
Acting type	Double acting						
Fluid	Air(to be filtered by 40µm filter element)						
Mounting type	Basic FA FB CA CB CR LB TC TCM1 TCM2						
JSI, JSIJ	Basic FA LB TC TCM1 TCM2						
Operating pressure	0.15~1.0MPa(22~145psi)(1.5~10.0bar)						
Proof pressure	1.5MPa(215psi)(15bar)						
Temperature °C	-20~70						
Speed range mm/s	30~800						30~500
Stroke tolerance	0~250 <sup>+1.0</sup> <sub>0</sub>		251~1000 <sup>+1.5</sup> <sub>0</sub>			1001~1500 <sup>+2.0</sup> <sub>0</sub>	
Cushion type	Variable cushion						
Adjustable cushion stroke	20	20.5			29	33	
Port size [Note1]	1/8"	1/4"		3/8"		1/2"	

[Note1] PT thread, G thread are available. Add) Refer to P362 for detail of sensor switch.

### Product feature

1. JIS standard cylinder.
2. The seal of piston adopts heterogeneous two way seal structure. It's dimension is tight and it has the function of greasel reservation.
3. The cylinder barrel is aluminum profile with hard anodizing treatment.
4. Compared with ISO15552 standard cylinder, the cylinder of JSI series with the same cylinder diameter is shorter.
5. The buffer adjustment of cylinder is smooth and steady.
6. Cylinders and mounting accessories for installation with several specifications are optional.

### Stroke

Bore size (mm)	Standard stroke (mm)																Max.std stroke	Max. stroke					
32	25	50	75	80	100	125	150	160	175	200	250	300	350	400	450	500	1000	1800					
40	25	50	75	80	100	125	150	160	175	200	250	300	350	400	450	500	600	700	800	900	1000	1200	1800
50	25	50	75	80	100	125	150	160	175	200	250	300	350	400	450	500	600	700	800	900	1000	1200	1800
63	25	50	75	80	100	125	150	160	175	200	250	300	350	400	450	500	600	700	800	900	1000	1500	1800
80	25	50	75	80	100	125	150	160	175	200	250	300	350	400	450	500	600	700	800	900	1000	1500	1800
100	25	50	75	80	100	125	150	160	175	200	250	300	350	400	450	500	600	700	800	900	1000	1500	1800
125	25	50	75	80	100	125	150	160	175	200	250	300	350	400	450	500	600	700	800	900	1000	1500	1800

[Note] Consult us for non-standard stroke.

### Ordering code

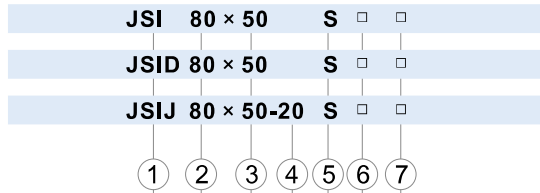

① Model	② Bore size	③ Stroke	④ Adjustable stroke	⑤ Magnet	⑥ Mounting type[Note1]	⑦ Thread type
JSI: Double acting type	32 40 50 63 80 100 125	Refer to stroke table for details	No this code	Blank: Without magnet S: With magnet	Blank	Blank: PT G: G
					LB	
					FA	
					FB	
					CA	
					CB	
JSID: Double rod type					Blank	
					LB	
JSIJ: Adjustable stroke type			10		FA	
			20			
			30			
			40			
			50			
			75			
			100			

[Note1] Please refer to page 54~56 for details of accessories ; TC is used with TCM1, TCM2.

# Standard cylinder

## JSI Series

### Inner structure and material of major parts

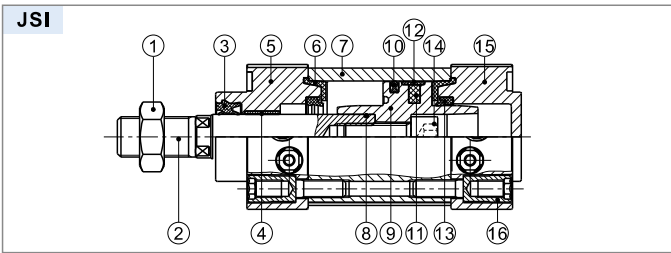

NO.	Item	Material
1	Rod nut	Carbon steel
2	Piston rod	Carbon steel with 20μm chrome plated or Stainless steel
3	Front cover packing	TPU
4	Bushing	Wear resistant material
5	Front cover	Aluminum alloy
6	O-ring	TPU
7	Barrel	Aluminum alloy
8	O-ring	NBR
9	Piston	Aluminum alloy
10	Piston seal	NBR
11	Magnet	Plastic
12	Wear ring	Wear resistant material
13	Buffer gasket	TPU
14	Screw	Carbon steel
15	Back cover	Aluminum alloy
16	Tie-rod nut	Carbon steel

### Dimensions

#### JSI

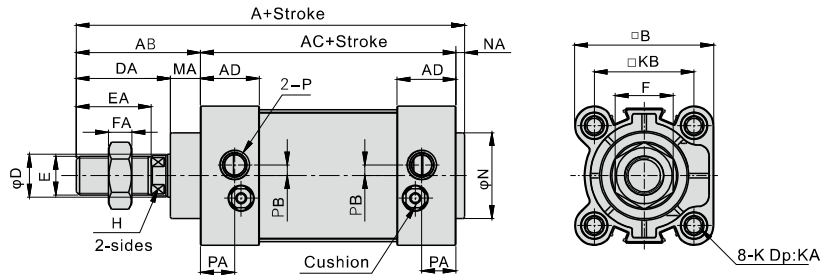

Bore size/Item	A	AB	AC	AD	B	D	DA	E	EA	F	FA	H	M	MA	K	KA	KB	N	NA	P	PA	PB
32	135	47	84	26	47	12	34	M10×1.25	22	17	6	10	30	13	M6	16	32.5	30	4	1/8"	13	5.5
40	139	51	84	25	53	16	38	M14×1.5	30	19	8	14	35	13	M6	16	38	35	4	1/4"	14	6
50	156	58	94	27.5	65	20	44	M18×1.5	35	27	11	18	40	14	M8	16	46.5	40	4	1/4"	16	5
63	156	58	94	27.5	75	20	44	M18×1.5	35	27	11	18	45	14	M8	16	56.5	45	4	3/8"	15	9
80	190	72	114	35	95	25	52	M22×1.5	40	32	13	22	45	20	M10	18	72	45	4	3/8"	19	11.5
100	190	72	114	35	115	32	52	M26×1.5	40	36	13	27	55	20	M10	18	89	55	4	1/2"	19	17
125	223	97	120	37.5	140	32	70	M27×2	54	41	13.5	27	60	27	M12	22	110	60	6	1/2"	20	17

Remark: The dimensions of magnet type cylinder are the same as non-magnet type cylinder.

#### JSID

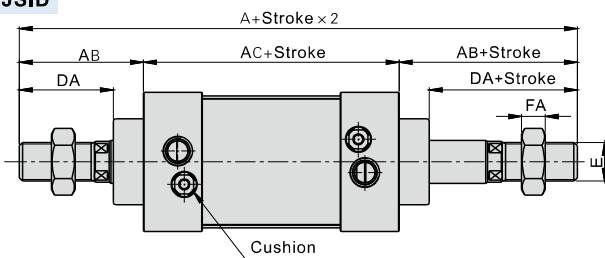

#### JSIJ

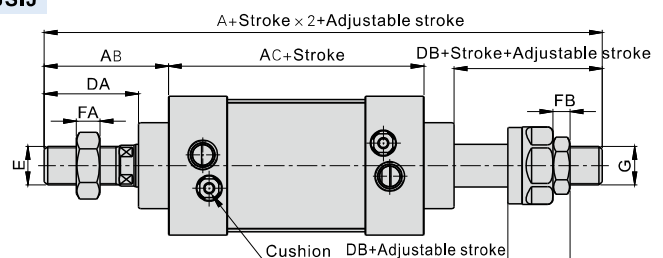

Bore size/Item	A(JSID)	A(JSIJ)	AB	AC	DA	DB	E	FA	FB	G
32	178	171	47	84	34	27	M10X1.25	6	6	M10X1.25
40	186	176	51	84	38	28	M14X1.5	8	7	M12X1.25
50	210	195	58	94	44	29	M18X1.5	11	8	M16X1.5
63	210	195	58	94	44	29	M18X1.5	11	8	M16X1.5
80	258	241.5	72	114	52	35.5	M22X1.5	13	10	M20X1.5
100	258	248.5	72	114	52	42.5	M26X1.5	13	13.5	M27X2.0
125	314	286.5	97	120	70	42.5	M27X2.0	13.5	13.5	M27X2.0

Remark:

- The dimensions of magnet type cylinder are the same as non-magnet type cylinder.
- The unmarked dimension is the same as JSI standard type.

# Standard cylinder

## JSI Series—Accessories

### List for ordering code of accessories

Accessories Bore size	Mounting accessories							
	LB	FA/FB	CA	CB	CR	TC	TCM1	TCM2
32	F-JSI32LB	F-SI32FA	F-JSI32CA	F-JSI32CB	F-JSI32CR	F-SAI32TC	F-SI32TCM1	F-SI32TCM2
40	F-JSI40LB	F-SI40FA	F-JSI40CA	F-JSI40CB	F-JSI40CR	F-SAI40TC	F-SI40TCM1	F-SI40TCM2
50	F-JSI50LB	F-SI50FA	F-JSI50CA	F-JSI50CB	F-JSI50CR	F-SAI50TC	F-SI40TCM1	F-SI40TCM2
63	F-JSI63LB	F-SI63FA	F-JSI63CA	F-JSI63CB	F-JSI50CR	F-SAI63TC	F-SI63TCM1	F-SI63TCM2
80	F-JSI80LB	F-SI80FA	F-JSI80CA	F-JSI80CB	F-JSI80CR	F-SAI80TC	F-SI63TCM1	F-SI63TCM2
100	F-JSI100LB	F-SI100FA	F-JSI100CA	F-JSI100CB	F-JSI80CR	F-SAI100TC	F-SI125TCM1	F-SI125TCM2
125	F-JSI125LB	F-JSI125FA	F-JSI125CA	F-JSI125CB	F-JSI125CR	F-SAI125TC	F-SI125TCM1	F-SI125TCM2

Accessories Bore size	Knuckle				Sensor	
	I : I Knuckle	Y : Y Knuckle	F : F Knuckle	U : U Knuckle	CMSE	DMSE
32	F-M10X125I	F-M10X125Y	F-M10X125F	F-M10X125U	CMSE	DMSE
40	F-M14X150I	F-M14X150Y	F-M14X150F	F-M14X150U		
50	F-M18X150I	F-M18X150Y	F-M18X150F	F-M18X150U		
63	F-M18X150I	F-M18X150Y	F-M18X150F	F-M18X150U		
80	F-M22X150I	F-M22X150Y	F-M22X150F	-		
100	F-M26X150I	F-M26X150Y	F-M26X150F	F-M26X150U		
125	F-M27X200I	F-M27X200Y	F-M27X200F	F-M27X200U		

### Accessory selection

Cylinder model	Accessories	Mounting accessories								Knuckle [Note1]				Sensor		
		LB	FA	FB	CA	CB	CR	TC	TCM1	TCM2	I	Y	U	F	CMSE	DMSE
JSI	Standard	●	●	●	●	●	●	●	●	●	●	●	●	●	●	●
	With magnet	●	●	●	●	●	●	●	●	●	●	●	●	●	●	●
JSID	Standard	●	●	x	x	x	x	●	●	●	●	●	●	●	x	x
	With magnet	●	●	x	x	x	x	●	●	●	●	●	●	●	●	●
JSIJ	Standard	●	●	x	x	x	x	●	●	●	●	●	●	●	x	x
	With magnet	●	●	x	x	x	x	●	●	●	●	●	●	●	●	●

[Note1] Please refer to P358-361 for knuckle detail.

### Material of accessories

Accessories Bore size	Mounting accessories								Knuckle				
	LB	FA	FB	CA	CB	CR	TC	TCM1	TCM2	I	Y	F	U
32-63	△	●	●	◇	◇	◇	◇	◇	●	□	□	□	□
80, 100	△	●	●	◇	◇	◇	◇	◇	●	□	◇	□	□
125	◇	◇	◇	◇	◇	◇	◇	◇	●	◇	◇	□	□

●—Aluminum alloy, ◇—Nodular cast iron, □—Carbon steel, △—SPCC.

### Dimensions

#### LB

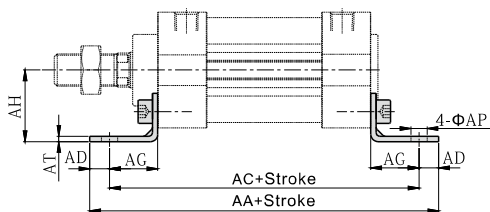

Bore size\Item	AA	AC	AD	AE	AF	AG	AH	AP	AT
32	146	128	9	50	32	22	30	7	3
40	154	132	11	55	38	24	33	9	3
50	170	148	11	70	46	27	40	9	3
63	176	148	14	80	56	27	45	12	4
80	202	174	14	100	72	30	55	12	5
100	210	178	16	120	89	32	65	14	5
125	250	210	20	136	90	45	81	14	8

#### CA

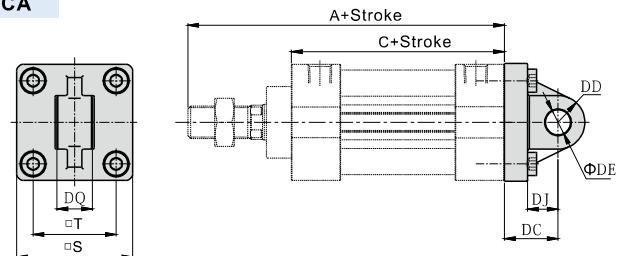

Bore size\Item	A	C	S	T	DC	DD	DE	DJ	DQ
32	131	84	46	32.5	23	10.5	10	13	13.8
40	135	84	52	38	23	11	10	13	13.8
50	152	94	65	46.5	30	15	14	17	19.8
63	152	94	75	56.5	30	15	14	17	19.8
80	186	114	95	72	42	17.5	22	27	29.8
100	186	114	114	89	42	17.5	22	27	29.8
125	217	120	136	110	50	28	25	28	31.8

# Standard cylinder

## JSI Series—Accessories

### FA/FB

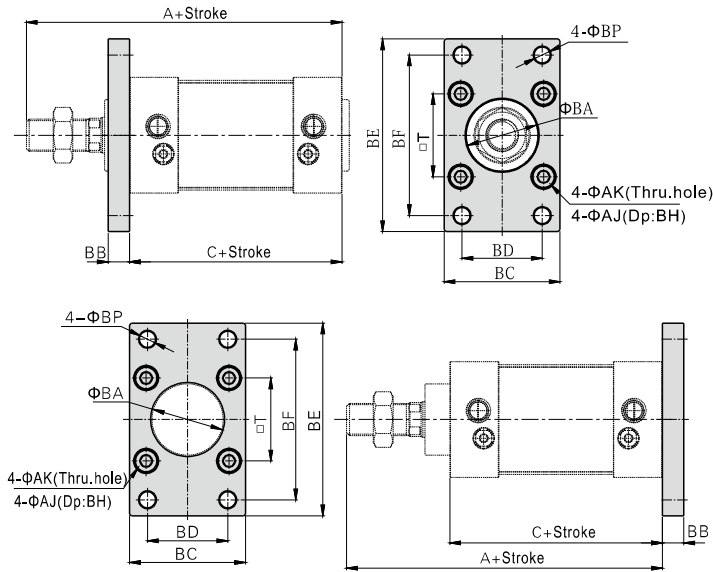

Bore size/Item	A	C	AJ	AK	BA	BB	BC	BD	BE	BF	BH	BP	T
32	131	84	11	6,5	30,5	10	47	32	80	64	6,5	7	32,5
40	135	84	11	6,5	35,5	10	53	36	90	72	6,5	9	38
50	152	94	14	9	40,5	12	65	45	108	90	8,5	9	46,5
63	152	94	14	9	45,5	12	75	50	118	100	8,5	9	56,5
80	186	114	17	11	45,5	16	95	63	150	126	10,5	12,5	72
100	186	114	17	11	55,5	16	115	75	176	150	10,5	14,5	89
125	217	120	19	13	60,5	20	138	102	216	180	12,5	14	110

### CB

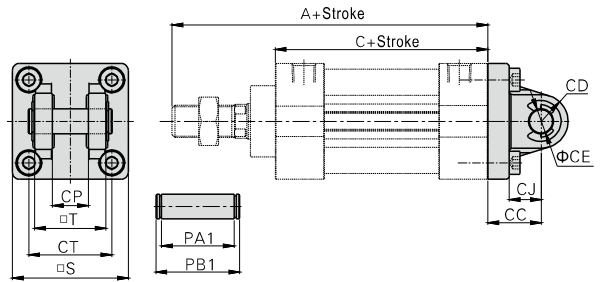

Bore size/Item	A	C	CC	CD	CE	CJ	CP	CT	PA1	PB1	S	T
32	131	84	23	10,5	10	14	14,2	32,5	28,8	34,6	46	28
40	135	84	23	11	10	14	14,2	38	28,8	34,6	52	28
50	152	94	30	15	14	18	20,2	46,5	40,8	47	65	40
63	152	94	30	15	14	18	20,2	56,5	40,8	47	75	40
80	186	114	42	20	22	27	30,2	72	60,8	69,2	95	60
100	186	114	42	20	22	27	30,2	89	60,8	69,2	114	60
125	217	120	50	25	25	32	32,2	110	64,8	73,2	136	64

### CR

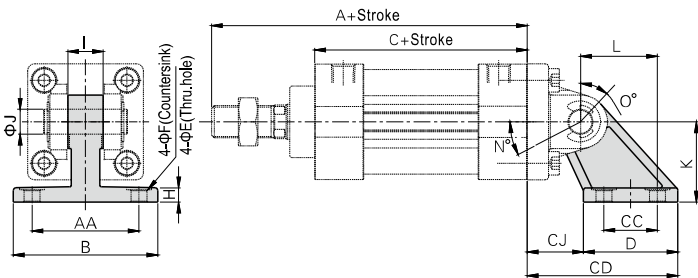

Bore size/Item	A	AA	B	C	CC	CD	CJ	D	E	F	H	I	J	K	L	N	O	N+O+90°
32	131	44	62	84	22	65	23	42	6,6	12	7	13,8	10	33	32	25	45	160
40	135	44	62	84	22	65	23	42	6,6	12	7	13,8	10	33	32	25	45	160
50	152	60	81	94	30	84,5	31,5	53	9	15	8	19,8	14	45	43	40	60	190
63	152	60	81	94	30	84,5	31,5	53	9	15	8	19,8	14	45	43	40	60	190
80	186	86	111	114	45	120	47	73	11	18	10	29,8	22	65	64	30	55	175
100	186	86	111	114	45	120	47	73	11	18	10	29,8	22	65	64	30	55	175
125	217	110	136	120	60	143	53	90	13,5	20	14	31,8	25	75	78	30	50	170

[Note] CR can't be used alone, it must be used with CB.

### TC

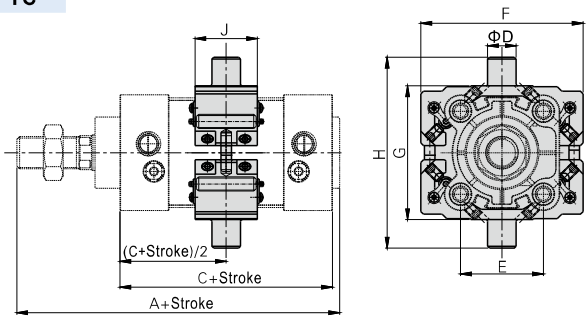

Bore size/Item	A	C	D	E	F	G	H	J
32	135	84	12	32,5	65	52	76	31
40	139	84	16	38	75	63	95	31
50	156	94	16	46,5	91	75	107	35
63	156	94	20	56,5	103	90	130	35
80	190	114	20	72	126	110	150	45
100	190	114	25	89	145	132	182	45
125	223	120	25	110	175	160	210	51



# Standard cylinder

## JSI Series—Accessories

**TCM1**

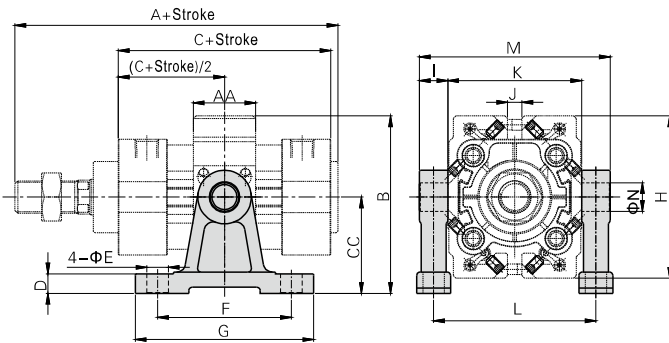

Bore size\Item	A	AA	B	C	CC	D	E	F	G	H	I	J	K	L	M	N
32	135	31	72.5	84	40	11	9	60	80	65	12	5	52	60	79	12
40	139	31	91.5	84	54	11	12	75	100	75	16	8	63	79	98	16
50	156	35	99.5	94	54	11	12	75	100	91	16	10	75	91	110	16
63	156	35	121.5	94	70	11	12	85	110	103	20	16	90	110	133	20
80	190	45	133	114	70	11	12	85	110	126	20	20	110	130	153	20
100	190	45	162.5	114	90	19	18	115	155	145	25	28	132	157	185	25
125	223	51	177.5	120	90	19	18	115	155	175	25	40	160	185	213	25

**TCM2**

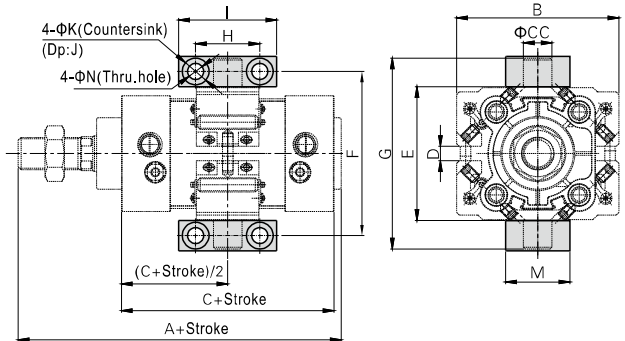

Bore size\Item	A	B	C	CC	D	E	F	G	H	I	J	K	M	N
32	135	65	84	12	5	52	68	82	32	46	6.8	11	30	7
40	139	75	84	16	8	63	82	99	36	55	9	15	36	9
50	156	91	94	16	10	75	94	111	36	55	9	15	36	9
63	156	103	94	20	16	90	113.5	134	42	65	11	18	40	11
80	190	126	114	20	20	110	133.5	154	42	65	11	18	40	11
100	190	145	114	25	28	132	159.5	184	50	75	14	20	50	14
125	223	175	120	25	40	160	187.5	212	50	75	14	20	50	14