

Control valve(3/2 way)

ZM3 Series



Symbol



Product feature

1. The activity direction could be changed(Only adapt to standard type, large angle type unavailable)

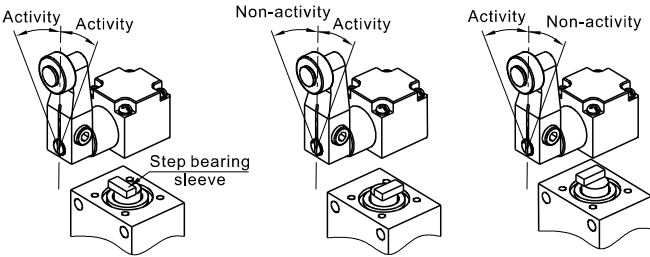

Position of standard activity

2. The rolling wheel could be installed at the inside of leverage

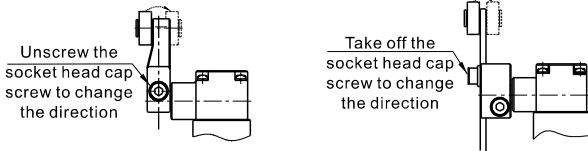

Specification

Model	ZM3R	ZM3J	ZM3P
Operating	External control direct acting type		
Fluid	Air (to be filtered by 40 μm filter element)		
Pressure range	-0.1~1.0MPa(-1~10bar)(-15~145psi)		
Proof pressure	1.5MPa(15bar)(215psi)		
Temperature	-20~70°C		
Valve type	3/2 Way		
Orifice size	6.0mm ² (Cv=0.34)		
Port size [Note1]	1/8"		
Lubrication [Note2]	Not required		
Material of body	Aluminum alloy		

[Note1] PT thread, G thread and NPT thread are available.

[Note2] Once lubricated air is used, continue with same medium to optimise valve life span. It is suggested to use ISO VG32 lubricant or the oil with the same grade.

3. Installation position of leverage could be changed

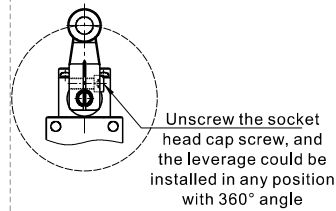

4. Direction of head part could be changed

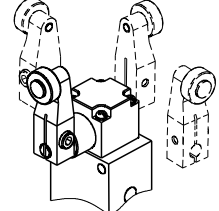

5. Length of contact pin could be changed

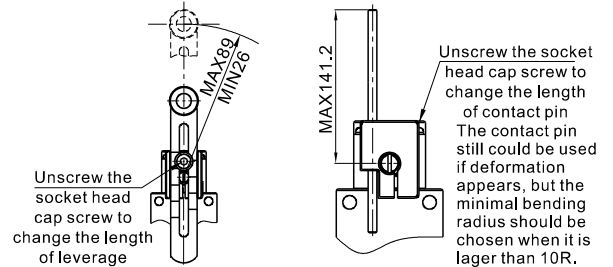

Ordering code

ZM3 R 06 W □

① ② ③ ④ ⑤

① Valve's type	② Model	③ Port size	④ Extreme angle of opening and closing of control head	⑤ Thread type
ZM3: ZM type 3/2 Way	R: Roller type J: Adjustable roller type P: Contact pin adjustable roller type	06: 1/8"	Blank: Standard type W: Large angle type	Blank: PT G: G T: NPT

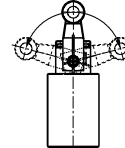

Flow chart

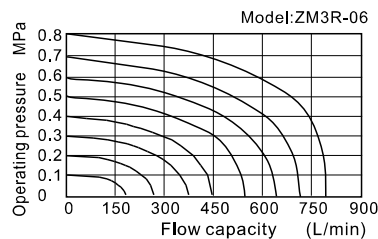

Control valve(3/2 way)

ZM3 Series



Inner structure

ZM3R

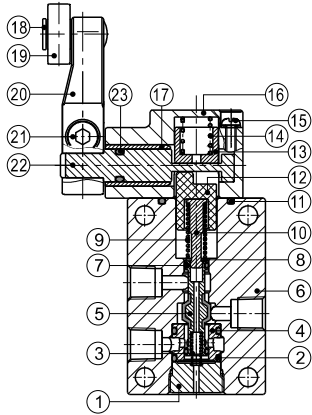

No.	Item	No.	Item
1	Bottom cover	13	Spring holder
2	O-ring	14	Spring
3	Spring	15	Screw
4	Spacer	16	Front cover
5	Spool	17	Bushing
6	Body	18	Shaft
7	O-ring	19	Roller
8	Spring washer	20	Rocker arm
9	Spring	21	Screw
10	Mandril	22	Rotation axis
11	O-ring	23	O-ring
12	Bushing		

Dimensions

ZM3R

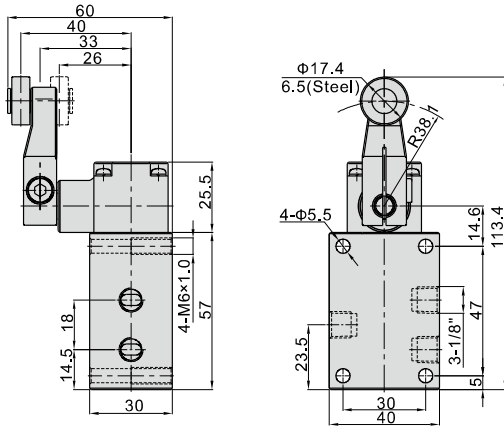

Model\Item	F.O.F	P.T.	O.T.	T.T.
ZM3R06	20N	20°	30°	50°
ZM3R06-W	20N	25°	50°	75°

ZM3J

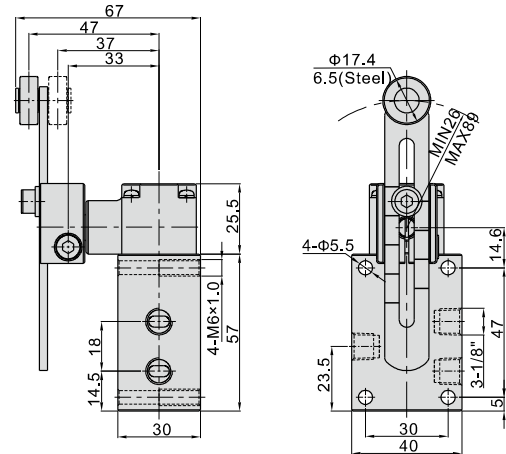

Model\Item	F.O.F [Note1]	P.T.	O.T.	T.T.
ZM3J06	20N	20°	30°	50°
ZM3J06-W	20N	25°	50°	75°

[Note1] When the length of leverage is 38.1mm

ZM3P

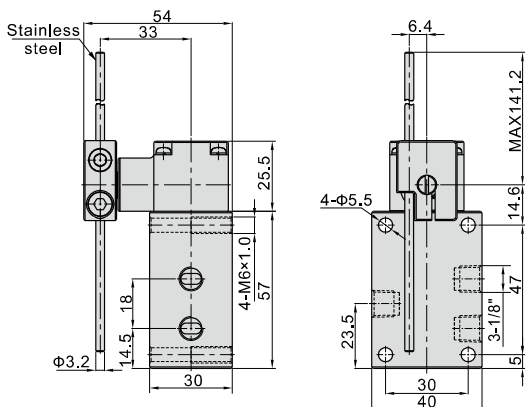

Model\Item	F.O.F [Note1]	P.T.	O.T.	T.T.
ZM3P06	2.3N	20°	30°	50°
ZM3P06-W	2.3N	25°	50°	75°

[Note1] When the length of leverage is 141.2mm

Description of symbol

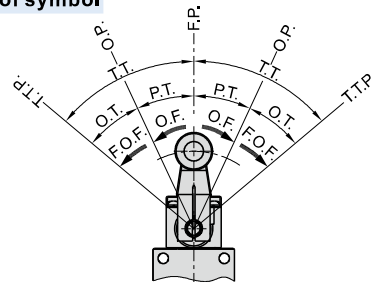

- F.P. Free position: the position of control head when no external force applied;
- O.P. Activity position: the position when the control head is applied with external force and the valve is switched;
- T.T.P. Extreme position of actuation: position of control head when it is pushed until end position;
- O.F. Actuation power: when driving from free position to actuation position, the operation power applied on control head;
- F.O.F. Extreme actuation power: when driving from free position to extreme actuation position, the operation power applied on control head;
- P.T. Free route: movement distance or rotation angle from free position of control head to actuation position;
- O.T. Actuation route: movement distance or rotation angle from actuation position of control head to extreme actuation position;
- T.T. Total route: movement distance or rotation angle from free position of control head to extreme actuation position;

